

QUEST

leisure products

Fulfilling your expectations...



2015

your essential catalogue for outdoor leisure, home & garden





Welcome to Quest

Established for over 30 years, Quest Leisure is a leading supplier of quality products to the caravan, camping, outdoor leisure, home and garden sectors. Our own brands are exclusively designed to meet customer needs in which we pride ourselves on the quality and features we build into them.

Our extensive range of products is available for all traditional and contemporary buyers within the camping and caravanning sector along with the home and garden sector too.

Within our warehouse we hold substantial stock ready for immediate delivery. Orders are normally despatched within 48 hours. Your orders can be placed with our sales team, sales office and online.

Contact us today and set up your own personal password to order 'online'.

Buy with Confidence

To be certain of obtaining higher quality products made to the highest possible standards, where manufacturing and testing processes are truly thorough, buy with confidence from Quest.

Not only do we have our own agents worldwide, you can be assured that we visit every one of our suppliers each year to give you a guarantee of continuous quality and confidence that products, processes and delivery match our excellent standards.

Always looking to improve our services, we have invested in our own infrastructure and, have dedicated staff covering all areas of our business on hand to help or offer guidance; simply give us a call.

At Quest we offer extra services and support to all of our customers as standard. These extra services and support are available to any of our customers, at any time and without any extra costs.

Dedicated Staff

We have a dedicated returns, parts and service team who look after all our returns and help with requests for parts and information on our products. We have multiple lines coming in on our standard number **(01527 516518)** which comes straight through to our office team who not only process your orders, but also provide first line help and support all of our customers.

We have a dedicated Canvas Queries team who look after all the queries, issues, warranties and registrations of our canvas models and are available to all of our customers.

Automated Services

We also offer automated stock services to any of our customers. This could be a simple automated email that lets you know current stock levels every day, or a full blown export of our products which contains, barcodes, stock status, extended descriptions and anything else.

We have also introduced an website extract which is specific to yourself and contains all the required information to help you maintain and update your own website easily and efficiently.

WEEE and Packaging Compliance

We have just introduced automated WEEE and Packaging Waste exports for customers as well. We know how difficult and time consuming collecting all the information required for the Government WEEE and Packaging regulations, so we have done all the work for you and can simply email you the totals whenever you wish.

We are always expanding the services we offer to our customers and if there are any specific requests you have, simply ask and we will investigate them for you.

Orders Can be Placed By:

Online Ordering:
my.questleisure.com

Telephone: 01527 516 518
Fax: 01527 516 519

E-Mail:
info@questleisure.com

or by your dedicated
Sales Manager

Leading Brands:



Tableware & Drinkware

Tableware	4 - 7
Gimex	6
Florence Glass Range	8
Everlasting Glass Range	9
Elegance Glass Range	10

Kitchen Products

Kitchen Products	11 - 13
Kettles and Tea Pots	14 - 18
Cookware, Toasters and Grills	19 - 20

Electrical, Heating, Cooling & Gas Products

Heating Range	21
Cooling Range	22 - 23
Lighting and Site Electrical	23
Kipor Generators	24
Platinum Batteries	25 - 26
Trojan Batteries	27
UK Giant Batteries	28
Gas Products	29 - 30

Caravan, Car & Tent Accessories

Car and Caravan Accessories	31 - 32
Clothes Lines, Airers and Ironing	33
Mats and Matting	34 - 36
Sleeping Bags	37 - 38

Bathroom

Bathroom Fluids	39
Elsan	39
Bathroom Accessories	40

Polish, Storage & Safety

Polishes and Cleaners	41 - 43
Fenwicks	41 - 42
Storage and Safety	43
Waterproofers and Sealants	44 - 45
Fabsil	44
Stormsure	45

Water & De-humidifiers

Pumps and Taps	46 - 48
Reich	47 - 48
Purifiers and Filters	49
Clean Tabs	49
De-Humidifiers	50
Kontrol	50

Outdoors

Outdoors, Picnics and Barbeques	51 - 52
Windbreaks	52

Furniture

Quest Elite® Ragley Range	53 - 54
Quest Elite® Sandringham Range	55 - 56
Quest Elite® Riviera Range	57 - 58
Quest Elite® Deluxe Range	59 - 60
Quest Elite® Comfort Plus Range	61
Quest Traveller Furniture Range	62 - 63
Quest Traveller Ibiza Range	64
Quest Children's Range	65
Westfield Outdoors® Avantgarde Range	66
Westfield Outdoors® Be-Smart Range	67
Westfield Outdoors® Performance Range	68
Westfield Outdoors® Accessories	69
Table and Table Sets	70 - 72
Camping Furniture	73
Furniture Accessories	74

Miscellaneous

Children's Toys	74
-----------------	----

Awnings, Gazebos & Shelters

Roll out of the Bag Awnings	75 - 76
Luxury Any Season Awnings	77 - 79
Lightweight Awnings	80
Air Awnings	81 - 84
Gazebos and Shelters	85 - 89
Annexes and Inner Tents	90 - 92
Awnings, Gazebos and Shelter Accessories	93 - 98

Terms and Conditions

Terms and Conditions	99
----------------------	----

Quest Tableware

Updated Designs, Timeless Quality

Here are the new Quest melamine tableware designs. All are premium quality prestige gold 100% melamine. There are modern and classic designs that will appeal to everyone.

Prestige gold melamine is premium quality melamine that is extremely durable and perfect for all alfresco dining. Easy to clean, scratch resistant and break resistant.



Burslem Two Tone Tableware

- Premium Heavyweight Melamine • Lightweight • Durable • Does not warp • Prestige Gold Melamine • Temperature Resistant • Stain Resistant
- Dishwasher Safe • Easy to clean

- **Mug:** 12 x 10 x 9cm. - Volume 350ml. - Weight: 0.15kg. • **Bowl:** 16 x 16 x 6cm. - Weight: 0.2kg.
- **Small Plate:** 21 x 21 x 2.5cm. - Weight: 0.19kg. • **Large Plate:** 28.5 x 28.5 x 3.5cm. - Weight: 0.31kg.
- **Salad Bowl:** 20 x 20 x 7.5cm. - Weight: 0.31kg. • **Oval Plate:** 32 x 21 x 3cm. - Weight: 0.4kg.

- Cat No** 150221
- Cat No** 150222
- Cat No** 150223
- Cat No** T0001

- Large Oval Plate**
- Salad Bowl**
- 16 Piece Dinner Set**
- Burslem 4 Piece Mug Set**

- Case Pack** 12
- Case Pack** 12
- Case Pack** 4
- Case Pack** 12



Sorrento Olive Tableware

- Premium Quality Melamine • Lightweight • Durable • Does not warp • Prestige Gold Melamine • Temperature Resistant • Stain Resistant
- Dishwasher Safe • Easy to clean

- **Mug:** 10 x 10 x 8cm. - Volume 350ml. - Weight: 0.1kg. • **Bowl:** 17.5 x 17.5 x 5cm. - Weight: 0.12kg.
- **Small Plate:** 20 x 20 x 1.5cm. - Weight: 0.12kg. • **Large Plate:** 25 x 25 x 2cm. - Weight: 0.18kg.
- **Salad Bowl:** 20 x 20 x 9cm. - Weight: 0.22kg. • **Oval Plate:** 30 x 22 x 1.5cm. - Weight: 0.2kg.

- Cat No** 150218
- Cat No** 150219
- Cat No** 150220

- Large Oval Plate**
- Salad Bowl**
- 16 Piece Dinner Set**

- Case Pack** 12
- Case Pack** 12
- Case Pack** 4



Quest Tableware

Updated Designs, Timeless Quality

Here are the new Quest melamine tableware designs. All are premium quality prestige gold 100% melamine. There are modern and classic designs that will appeal to everyone.

Prestige gold melamine is premium quality melamine that is extremely durable and perfect for all alfresco dining. Easy to clean, scratch resistant and break resistant.



Tahiti Tableware

- Premium Quality Melamine • Lightweight • Durable • Does not warp • Prestige Gold Melamine • Temperature Resistant • Stain Resistant
- Dishwasher Safe • Easy to clean

- **Mug:** 11 x 10 x 8.5cm. - Volume 350ml. - Weight: 0.13kg. • **Bowl:** 15 x 15 x 7.5cm. - Weight: 0.15kg.
- **Small Plate:** 20 x 20 x 1.5cm. - Weight: 0.16kg. • **Large Plate:** 28 x 28 x 3cm. - Weight: 0.4kg.
- **Salad Bowl:** 20 x 20 x 9cm. - Weight: 0.22kg. • **Oval Plate:** 22 x 29.5 x 2cm. - Weight: 0.18kg.

Cat No 150227 **Large Oval Plate**
Cat No 150228 **Salad Bowl**
Cat No 150229 **16 Piece Dinner Set**

Case Pack 12
Case Pack 12
Case Pack 4



Seychelles Tableware

- Premium Quality Melamine • Lightweight • Durable • Does not warp • Prestige Gold Melamine • Temperature Resistant • Stain Resistant
- Dishwasher Safe • Easy to clean

- **Mug:** 11 x 10 x 8.5cm. - Volume 350ml. - Weight: 0.13kg. • **Bowl:** 15 x 15 x 7.5cm. - Weight: 0.15kg.
- **Small Plate:** 20 x 20 x 1.5cm. - Weight: 0.16kg. • **Large Plate:** 28 x 28 x 3cm. - Weight: 0.4kg.
- **Salad Bowl:** 20 x 20 x 9cm. - Weight: 0.22kg. • **Oval Plate:** 22 x 29.5 x 2cm. - Weight: 0.18kg.

Cat No 150230 **Large Oval Plate**
Cat No 150231 **Salad Bowl**
Cat No 150232 **16 Piece Dinner Set**

Case Pack 12
Case Pack 12
Case Pack 4



12 Piece Dinner Set

Case Pack 8

- Premium quality • Lightweight • Durable • Does not warp • Easy to clean
- Temperature Resistant • Stain Resistant • Dishwasher Safe
- Set consists of : 4 Dinner Plates • 4 Side Plates • 4 Cereal Bowls

Cat No 100007 Grey and Lime

Cat No 100014 Grey and Blue

Cat No 100021 Grey and Blackberry



Matching Mug

Case Pack 12

- Premium quality • Lightweight • Durable • Does not warp • Easy to clean
- Temperature Resistant • Stain Resistant • Dishwasher Safe

Cat No 100008 Grey and Lime

Cat No 100015 Grey and Blue

Cat No 100022 Grey and Blackberry



16 Piece Cutlery Set

Case Pack 6

- Premium quality • Lightweight • Durable • Stainless steel • Easy to clean
- Durable

Cat No 100031 Lime

Cat No 100030 Blue

Cat No 100032 Blackberry



Tumbler with Waterproof lid and Straw

Case Pack 12

- Premium quality • Lightweight • Durable • Does not warp
- Temperature resistant • Stain Resistant • Dishwasher Safe • Easy to clean

Cat No 100010 Lime

Cat No 100017 Blue

Cat No 100024 Blackberry



Salad Bowls and Servers

- Premium quality • Lightweight • Durable • Does not warp • Temperature resistant • Stain Resistant • Dishwasher Safe • Easy to clean

Description	Lime Cat No	Blue Cat No	Blackberry Cat No	Case Pack
Salad Bowl	100011	100018	100025	6
Small Salad Bowl	100012	100019	100026	12
Salad Servers	100013	100020	100027	12



Cat No 0196
Mini Stainless Steel Salt and Pepper Mills

Mini Stainless Steel Mills Supplied in a Counter Display Case of 12

Case Pack 1



Cat No 070500
Thermoclean 4pack (display box of 30)

- Removes stains • Neutralises odours • Quick and Simple to Use
- No Scrubbing • Does not Bleach • Home or Work • Strip of 4 Packs
- Display Box of 30 Strips

Case Pack 2



Cat No K0004
Coffee Canister

- Stainless Steel • High Quality • Cream Body
- Polished Steel Top
- Size: 9 x 9 x 15 cm. • Weight: 0.2 kg.

Case Pack 12



Cat No K0005
Tea Canister

- Stainless Steel • High Quality • Cream Body
- Polished Steel Top
- Size: 9 x 9 x 15 cm. • Weight: 0.2 kg.

Case Pack 12



Cat No K0006
Sugar Canister

- Stainless Steel • High Quality • Cream Body
- Polished Steel Top
- Size: 9 x 9 x 15 cm. • Weight: 0.2 kg.

Case Pack 12



Cat No 010005
Quest 20 Piece Plastic Dinner Set

- Extremely Lightweight • 4 Dinner Plates • 4 Side Plates • 4 Knives • 4 Forks
- 4 Spoons • Dinner Plate: 25 cm • Side Plate: 18.75 cm
- Entire Box Size: 36 x 24 x 3 cm

Case Pack 16



3 Piece Plastic Canister Set

- Lightweight • Easy to clean • Coffee, Sugar and Tea

Case Pack 9

- Cat No 1029** Oatmeal
- Cat No 1029CH** Charcoal
- Cat No 1029S** Silver

Florence Drinkware Range Style and Strength

Break resistant tableware. Made from acrylic, they are tough, light and ideal for camping or travelling. The Florence range of drinkware has a timeless style and is ideal for any alfresco dining.

Not recommended for use in dishwasher or microwave oven. Do not use boiling water direct on glass.

Features:

Premium Quality
Touch and Feel of Real Glass



High Tumbler

Case Pack 12

- Premium Quality • Touch and Feel of Real Glass • Tinted Colour
- Break Resistant • Stain Resistant • Durable
- Height: 16cm • Width: 9 cm. • Volume: 600ml. • Weight: 0.14 kg.
- Acrylic Weight: XX oz.

- Cat No 150180 Blue**
Cat No 150183 Clear
Cat No 150187 Purple



Low Tumbler

Case Pack 12

- Premium Quality • Touch and Feel of Real Glass • Tinted Colour
- Break Resistant • Stain Resistant • Durable
- Height: 11cm • Width: 9 cm. • Volume: 400ml • Weight: 0.11kg
- Acrylic Weight: XX oz.

- Cat No 150181 Blue**
Cat No 150184 Clear
Cat No 150188 Purple



Wine Glass

Case Pack 12

- Premium Quality • Touch and Feel of Real Glass • Tinted Colour
- Break Resistant • Stain Resistant • Durable
- Height: 21cm • Width: 8 cm. • Volume: 350ml • Weight: 0.15 kg.
- Acrylic Weight: XX oz.

- Cat No 150182 Blue**
Cat No 150185 Clear
Cat No 150189 Purple





Everlasting Drinkware Range
Virtually Unbreakable

The Everlasting range is a great solution for outdoor entertaining. These glasses are made to be used outdoors, from pool parties and picnics to holidays and barbecues. The premium quality of the materials means that this range not only looks like glass, but feels like glass and its extreme strength makes it virtually unbreakable.

- Features:**
Premium Quality
Virtually Unbreakable.
Looks and Feels Like Glass.



Cat No 0180
250ml Tumbler Clear

- Premium Quality • Virtually Unbreakable • Looks and Feels Like Glass
- Height: 8cm, Width: 7.5 cm, Volume: 250ml

Case Pack 12



Cat No 0181
440ml Hi Tumbler Clear

- Premium Quality • Virtually Unbreakable • Looks and Feels Like Glass
- Height: 13.5cm, Width: 7.5 cm, Volume: 440ml.

Case Pack 12



Cat No 0182
240ml Goblet Clear

- Premium Quality • Virtually Unbreakable • Looks and Feels Like Glass
- Height: 15cm, Width: 6.5 cm, Volume: 240ml

Case Pack 12



Cat No 0213
Spectrum 4 Piece Mug Set

- High Quality • 100% Melamine Mugs • Supplied in four different colours.
- Set Consists of : 4 Mugs in a display box

Case Pack 12

Elegance Drinkware Range
Virtually Unbreakable

Break resistant tableware. Made from acrylic, they are tough, light and ideal for camping or travelling. Not recommended for use in dishwasher or microwave oven. Do not use boiling water direct on glass.

Features:

- Premium Quality
- Touch and Feel of Real Glass



Tumbler

Case Pack 12

- Premium Quality • Touch and Feel of Real Glass • Smoked Coloured Base
- Height: 10 cm, Width: 8 cm, Volume: 280ml, Acrylic Weight: 8oz.

- Cat No 0184 Smoked**
- Cat No 0184BL Blue**
- Cat No 0184L Lime**



Hi Tumbler

Case Pack 12

- Premium Quality • Touch and Feel of Real Glass • Smoked Coloured Base
- Height: 15 cm, Width: 6.5 cm, Volume: 300ml, Acrylic Weight: 11oz.

- Cat No 0185 Smoked**
- Cat No 0185BL Blue**
- Cat No 0185L Lime**



Wine Glass

Case Pack 12

- Premium Quality • Touch and Feel of Real Glass • Smoked Coloured Base
- Height: 18 cm, Width: 7 cm, Volume: 280ml, Acrylic Weight: 10oz.

- Cat No 0186 Smoked**
- Cat No 0186BL Blue**
- Cat No 0186L Lime**



Bella Goblet

Case Pack 12

- Premium Quality • Touch and Feel of Real Glass • Smoked Coloured Base
- Height: 15 cm, Width: 8 cm, Volume: 400ml, Acrylic Weight: 10oz.

- Cat No 0187 Smoked**
- Cat No 0187BL Blue**
- Cat No 0187L Lime**



Cat No K0002
Cream Plate Drainer

- Lightweight • Easy to Clean • Easy to Assemble • Slots Together
- Easy to Store • Holds Plates and Cutlery • Built in Drip Tray
- Size: 34 x 24 x 10 cm. • Folded: 40 x 15 x 8 cm.
- Weight: 0.4 kg.

Case Pack 12



Cat No K0003
Aubergine Plate Drainer

- Lightweight • Easy to Clean • Easy to Assemble • Slots Together
- Easy to Store • Holds Plates and Cutlery • Built in Drip Tray
- Size: 34 x 24 x 10 cm. • Folded: 40 x 15 x 8 cm.
- Weight: 0.4 kg.

Case Pack 12

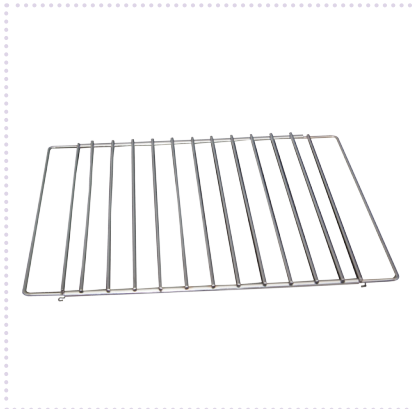

Cat No 031249
Quest Universal Oven Shelf

- Universal • Lightweight • Chrome Finish
- Size: 32 x 36cm

Case Pack 25

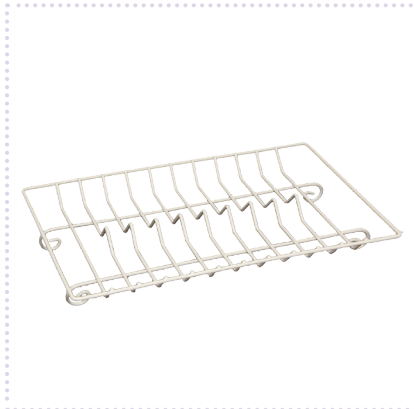

Cat No 031200
Quest Mini Dish Drainer Powder Coated

- Lightweight • Small Footprint • Easy to Clean
- Cream Powder Coated Finish
- Size: 30 x 22 x 6cm

Case Pack 12



Cat No 031201
Quest Mini Dish Drainer With Tray

- Lightweight • Extra Drip Height • Easy to Clean
- Removable Drip Tray
- Cream Powder Coated • Size: 26 x 20 x 10cm

Case Pack 12



Cat No 1232
Food Umbrella

- Easy to Store • Covers Food • Increases Food Hygiene • Keeps Insects off your food
- Size: 40 x 40 x 23cm. • Folded: 40 x 4 cm.
- Weight: 60 g.

Case Pack 12



Cat No 1190
Splatter Screen

- For covering pans and pots while in use
- Stops the fat from spitting • Increases safety
- Helps keep kitchen cleaner
- Size: 32 x 46 cm. • Guard Size: 29 cm.
- Weight: 0.1 kg.

Case Pack 12



Cat No 1271
Dust Pan and Brush

- Lightweight • Tough and Durable Plastic
- Assorted colours

Case Pack 12



Cutlery Holder

Case Pack 12

- Lightweight • Easy to Clean
- High Quality Plastics

Cat No 1126 Oatmeal
Cat No 1126CH Charcoal
Cat No 1126S Silver



Studio Drainer

Case Pack 12

- Lightweight • Easy to Clean
- High Quality Plastics

Cat No 1127 Oatmeal
Cat No 1127CH Charcoal
Cat No 1127S Silver



Colander

Case Pack 12

- Lightweight • Easy to Clean
- High Quality Plastics

Cat No 1139 Oatmeal
Cat No 1139S Silver
Cat No 1139CH Charcoal



25cm Round Bowl

Case Pack 12

- Lightweight • Tough and Durable Plastic.
- Can also be used for storage.

Cat No 1226 Oatmeal
Cat No 1226S Silver
Cat No 1226CH Charcoal

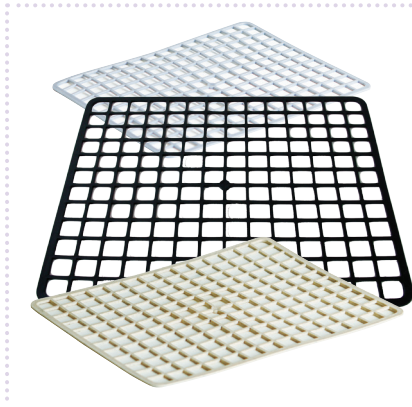

Sink Mat

Case Pack 12

- Lightweight • Tough and Durable Plastic.
- Protects surfaces and tableware
- Size: 32.5 x 26.25 cm

Cat No 1228 Oatmeal
Cat No 1228S Silver
Cat No 1228CH Charcoal



Square Bowl

Case Pack 12

- Lightweight • Tough and Durable Plastic.
- Can be used for storage. • Size: 29 x 31 x 13cm

Cat No 1229 Oatmeal
Cat No 1229S Silver
Cat No 1229CH Charcoal



Cutlery Tray

Case Pack 12

- Lightweight • Tough and Durable Plastic.
- Ideal for the caravan. • Size: 24 x 34.5 x 4.5cm

Cat No 1234 Oatmeal
Cat No 1234S Silver
Cat No 1234CH Charcoal



12 Litre Bucket

Case Pack 12

- Strong • Durable • Easy to Clean • Lightweight
- Carry Handle
- Size: 24 x 34.5 x 4.5cm • Volume: 12L

Cat No 1268 Oatmeal
Cat No 1268S Silver
Cat No 1268CH Charcoal



Swing Top Bin 10 Litre

Case Pack 5

- Lightweight • Tough and Durable Plastic.
- Strong and Robust.

Cat No 1272 Oatmeal
Cat No 1272S Silver
Cat No 1272CH Charcoal



Garbina Bags and Bins Case Pack 6

Designed to fit on the inside of a cupboard door and comes complete with all fixings.
 • Bin Size: 32cm wide x 16cm radius.

Cat No 1244 Garbina Waste Bin

Cat No 1245 Garbina Extra Bags (25)



Cat No 1273 Eko Bin Case Pack 12

• Lightweight • Simply clicks Together
 • Fold flat Waste Bin • 3 Adjustable Heights.



Cat No 1296 Carrier Bag Bin Case Pack 1

• Turns any Standard Plastic Bag into a Bin
 • Lightweight • Easy to use



Cat No 1069 Metaltex Sidewinder Can Opener Case Pack 3

• Display box of 18 • Strong and robust
 • Easy to Use
 • Dishwasher safe
 • Ideal for home, camping or caravan and motorhome use



Cat No 1070 Metaltex Peeler Case Pack 3

• Display box of 48 • Strong and robust
 • Easy to Use
 • Dishwasher safe
 • Ideal for home, camping or caravan and motorhome use



Cat No 4923 Metaltex Scissors Case Pack 3

• Display box of 18 • Strong and robust
 • Easy to Use
 • Dishwasher safe
 • Ideal for home, camping or caravan and motorhome use



Cat No 4925 Metaltex Wash Brush Case Pack 3

• Display box of 24 • High Quality • Easy to Use • Nylon Bristles
 • Injection moulded handle
 • Mixed box of blue, beige and green
 • A must have cleaning accessory for the home, caravan and motorhome.



Cat No 4926 Metaltex Fly Swat Case Pack 3

• Display box of 120 • High Quality • Easy to Use • Injection moulded
 • Mixed box of blue, beige, grey and green
 • A great accessory at home and especially when out and about in your caravan or motorhome.

Kettles and Tea Pots

Every Type you'll Ever Need

Quest have a great and extensive range of kettles and tea pots. They range from the standard camping kettle to high quality stainless steel electric kettles that are nopt out of place at home as well as in the caravan or motorhome.



Cat No 031141
3L Green Oval Kettle

- High Quality • All Metal Construction • Lightweight
- Spout Button on Handle • Soft Touch Handle and Top
- Premium High Gloss Finish
- Capacity: 3.0 Litres • Size: 21 x 21 x 22 cm • Weight: 0.65 kg

Case Pack 6



Cat No 031141B
3L Blue Oval Kettle

- High Quality • All Metal Construction • Lightweight
- Spout Button on Handle • Soft Touch Handle and Top
- Premium High Gloss Finish
- Capacity: 3.0 Litres • Size: 21 x 21 x 22 cm • Weight: 0.65 kg.

Case Pack 6



Cat No 031141P
3L Purple Oval Kettle

- High Quality • All Metal Construction • Lightweight
- Spout Button on Handle • Soft Touch Handle and Top
- Premium High Gloss Finish
- Capacity: 3.0 Litres • Size: 21 x 21 x 22 cm • Weight: 0.65 kg

Case Pack 6



Cat No 031141R
3L Red Oval Kettle

- High Quality • All Metal Construction • Lightweight
- Spout Button on Handle • Soft Touch Handle and Top
- Premium High Gloss Finish
- Capacity: 3.0 Litres • Size: 21 x 21 x 22 cm • Weight: 0.65 kg.

Case Pack 6



Cat No 031144
2.5L Green Folding Handle Kettle

Case Pack 6

- High Quality • All Metal Construction • Lightweight • Excellent Finish
- Handle Folds Away • Easy to Store
- Capacity: 2.5 L • Size: 23 x 22 x 19 cm
- Folded Size: 15 x 22 x 19 cm • Weight: 0.35 kg



Cat No 031145
2.5L Red Folding Handle Kettle

Case Pack 6

- High Quality • All Metal Construction • Lightweight • Excellent Finish
- Handle Folds Away • Easy to Store
- Capacity: 2.5 L • Size: 23 x 22 x 19 cm
- Folded Size: 15 x 22 x 19 cm • Weight: 0.35 kg



Cat No 031155R
Quest 2.5L Whistling Kettle

Case Pack 6

- High Quality • All Metal Construction • Lightweight • Whistle Spout
- Soft Touch Handle • Soft Touch Spout Handle
- High Gloss Finish • Stay Cool handle
- Capacity: 2.5 Litres • Size: 20 x 22 x 23 cm • Weight: 0.5 kg.



Cat No 031155P
Quest 2.5L Whistling Kettle

Case Pack 6

- High Quality • All Metal Construction • Lightweight • Whistle Spout
- Soft Touch Handle • Soft Touch Spout Handle
- High Gloss Finish • Stay Cool handle
- Capacity: 2.5 Litres • Size: 20 x 22 x 23 cm • Weight: 0.5 kg.



Cat No 031155R
Quest 2.5L Whistling Kettle

Case Pack 6

- High Quality • All Metal Construction • Lightweight • Whistle Spout
- Soft Touch Handle • Soft Touch Spout Handle
- High Gloss Finish • Stay Cool handle
- Capacity: 2.5 Litres • Size: 20 x 22 x 23 cm • Weight: 0.5 kg.



Cat No 1143B
2.2L Stainless Steel Whistling Kettle

Case Pack 12

- High Quality • All Metal Construction • Cool Touch Nylon Handle
- Lightweight • Whistle Spout • Excellent Finish
- Gas, electric, glass or ceramic hobs.
- Colour: Black • Capacity: 2.2 Litres
- Size: 19 x 19 x 20 cm • Weight: 415 g



Cat No 1143C
2.2L Stainless Steel Whistling Kettle

Case Pack 12

- High Quality • All Metal Construction • Cool Touch Nylon Handle
- Lightweight • Whistle Spout • Excellent Finish
- Gas, electric, glass or ceramic hobs.
- Colour: Cream • Capacity: 2.2 Litres
- Size: 19 x 19 x 20 cm • Weight: 415 g



Cat No 1177
Stainless Steel Teapot 900ml

Case Pack 12

- High Quality • Stainless Steel and Glass • Ideal for any loose leaf tea
- Last for years • Capacity: 900ml.



Cat No 1153
2 Litre Stainless Steel Whistling Kettle

Case Pack 12

- High Quality • Stainless Steel • Lightweight • Whistle Spout
- Easy Pour Spout • Can be used on gas, electric, glass or ceramic hobs.
- Capacity: 2 Litres • Size: 20 x 20 x 20 cm • Weight: 387 g.



Cat No 1161B
1.2L Blue Whistling Kettle

Case Pack 12

- Easy to Use • High Quality • Lightweight • Aluminium Base
- Ideal for Camping • Whistle Function • Easy Pour Spout
- Capacity: 1.2 Litre • Size: 17 x 17 x 14 cm • Weight: 214 g.



Cat No 1161R
1.2L Red Whistling Kettle

Case Pack 12

- Easy to Use • High Quality • Lightweight • Aluminium Base
- Ideal for Camping • Whistle Function • Easy Pour Spout
- Capacity: 1.2 Litre • Size: 17 x 17 x 14 cm • Weight: 214 g.



Cat No 1161G
1.2L Green Whistling Kettle

- Easy to Use • High Quality • Lightweight • Aluminium Base
- Ideal for Camping • Whistle Function • Easy Pour Spout
- Capacity: 1.2 Litre • Size: 17 x 17 x 14 cm • Weight: 214 g.

Case Pack 12



Cat No 1162R
2L Red Whistling Kettle

- Easy to Use • High Quality • Lightweight • Aluminium Base
- Ideal for Camping • Whistle Function • Easy Pour Spout
- Capacity: 2 Litres • Size: 19 x 19 x 16 cm • Weight: 288 g.

Case Pack 12



Cat No 1162G
2L Green Whistling Kettle

- Easy to Use • High Quality • Lightweight • Aluminium Base
- Ideal for Camping • Whistle Function • Easy Pour Spout
- Capacity: 2 Litres • Size: 19 x 19 x 16 cm • Weight: 288 g.

Case Pack 12



Cat No 1147
Quest Dual Voltage Travel Kettle

- Low Wattage • Lightweight • Concealed Element • Dual Voltage
- Twin Water Level Window
- Capacity: 0.5 L • Voltage to 110-120V / 220-240V
- Frequency: 60Hz / 50Hz • Wattage: 550-650W

Case Pack 6



Cat No 114614W
1.7L White Low Wattage Cordless Kettle

- Low Wattage • Cordless • Twin Water Level Indicators • Snap Shut Lid
- Easy Grip Soft Touch Handle • Stainless Steel Heating Tube
- Removable and Washable Filter • Power Indicator Light • Safety Cut Off
- Size: 22 x 22 x 13 cm. • Weight: 0.7 kg.
- Capacity: 1.7L • Voltage: 220 - 240V • Frequency: 50Hz • Wattage: 1100W

Case Pack 6



Cat No 114614B
1.7L Black Low Wattage Cordless Kettle

- Low Wattage • Cordless • Twin Water Level Indicators • Snap Shut Lid
- Easy Grip Soft Touch Handle • Stainless Steel Heating Tube
- Removable and Washable Filter • Power Indicator Light • Safety Cut Off
- Size: 22 x 22 x 13 cm. • Weight: 0.7 kg.
- Capacity: 1.7L • Voltage: 220 - 240V • Frequency: 50Hz • Wattage: 1100W

Case Pack 6



Kettles and Tea Pots

Every Type you'll Ever Need

Quest have a great and extensive range of kettles and tea pots. They range from the standard camping kettle to high quality stainless steel electric kettles that are npt out of place at home as well as in the caravan or motorhome.



Cat No K0017
Cream 1.7L Low Wattage Stainless Steel Kettle

- Low Wattage • Cordless • Water Level Indicator • Stainless Steel
 - Large Capacity • 360° Base • Power Indicator
 - Removable and Washable Filter • Automatic Shut Off • Manual Override
 - Safety Cut Off • Push Button Lid • Built in Cable Tidy
- Size: 17 x 17 x 25 cm. • Weight (with base): 0.9 kg.
• Capacity: 1.7L • Voltage: 220 - 240V • Frequency: 50Hz • Wattage: 1000W



Cat No K0020
Purple 1.8L Low Wattage Stainless Steel Kettle

- Low Wattage • Cordless • Water Level Indicator • Stainless Steel
 - Large Capacity • 360° Base • Power Indicator
 - Removable and Washable Filter • Automatic Shut Off • Manual Override
 - Safety Cut Off • Built in Cable Tidy
- Size: 20 x 20 x 30 cm. • Weight (with base): 1.2 kg. • Capacity: 1.8L
• Voltage: 220 - 240V • Frequency: 50Hz • Wattage: 1000W



Cat No 044937
Red Stainless Steel Kettle 1.7L

- Stainless Steel Body • Cordless Kettle • 360° Base • Cord storage
- Automatic switch off • Over-heat protection • Low Wattage
- Capacity: 1.7 L • Voltage: 220-240V • Frequency: 50/60Hz
- Wattage: 950-1100W • Size: 26 x 21 x 15 cm • Weight: 0.94kg



Cat No K0016
1.2L Low Wattage Stainless Steel Kettle

- Polished Stainless Steel Body • Cordless • 360° Base • Cord Storage
- Automatic switch off • Over-heat protection • Low Wattage
- Size: 23 x 18 x 15 cm • Weight: 0.8kg • Capacity: 1.2 L
- Voltage: 220 - 240V • Frequency: 50/60Hz • Wattage: 1000W



Cat No 115214W **Case Pack** 8
1L Low Wattage Cordless Kettle

- Water Level Indicator • Power Light
- Safety Lid • Automatic Switch Off
- Manual Override • Over Heat Protection
- Heat Resistant • Easy Clean • Capacity: 1L
- Hertz: 220-240v 50Hz • Wattage: 850 watts.



Cat No 031256 **Case Pack** 12
20cm Non Stick Frying Pan

- Non Stick • Easy to Clean • Cool Touch Handle.
- Lightweight. • Red Base
- For Use on Gas and Electric stoves.



Cat No 031255 **Case Pack** 12
Non Stick Milk Pan with Red Base

- Lightweight • Non Stick Surface • Easy to Clean
- Cool Touch Handle.
- For Use on Gas and Electric Stoves
- Size: 20 x 20 cm • Weight: kg.



Cat No 1238B **Case Pack** 6
Quest 3 Piece Non Stick Charcoal Pan Set

- 3 Piece Pan set in Charcoal • 3 different Size Pans • Matching lids • Non Stick Coating • Bakerlite Cool Touch Handles
- High Quality • Lightweight • Easy to Clean • Non Stick Coating
- Sizes: 16cm, 18cm and 20cm.



Cat No K0013 **Case Pack** 12
Folding Handle Grill Pan

- Lightweight • High Quality Enamelling • Durable
- Easy to Clean • Extra Deep Pan
- Non-Stick Wire Rack
- Size: 28 x 22 x 4 cm



Cat No K0014 **Case Pack** 12
Square Grill Pan with Folding Handle

- Lightweight • Handle folds away for easy storage
- Wooden Handle • Non Stick Surface
- Cooking ring to aid even heat dispersion
- Grill Size: 20 x 20 cm • Weight: 0.5 kg
- Size: 40 x 20 x 3 cm • Folded: 20 x 20 x 3 cm



Cat No K0001 **Case Pack** 12
Aluminium Pizza and Paella Pan

- Lightweight • Non Stick • Easy to Clean
- Grill Size: 24 cm • Weight: xx kg
- Size: xxxxx cm • Depth: 2.5 cm



Low Wattage Toaster

- Low Wattage • Temperature Control • Cancel Button • Removable Crumb Tray • Built in Cable Tidy
- Size: 16 x 12.5 x 24 cm • Weight: 1 kg • Voltage: 220-240V • Frequency: 50Hz • Wattage: 750W
- 2 Toast Slots

Cat No 2066: White
Cat No 2066B: Black

Case Pack 6

Cat No 2068

Case Pack 6

Low Wattage Stainless Steel Toaster

- Low Wattage • Temperature Control
- Cancel Button • Easy to Use • Easy to Clean
- Removable Base for Cleaning
- Size: 22 x 16 x 12 cm • Weight: 0.79 kg
- Voltage: 230V • Wattage: 750W



Cat No 7505
Quest Healthy Griddle

Case Pack 6

- Low Wattage • Lightweight
- Automatic Temperature Control
- Non-stick Coating • Cool Touch Handle
- Complete with Oil Tray • Griddle: 27 x 27 x 7 cm
- Size: 40 x 27 x 9cm

Cat No 7506
Quest Stainless Steel Mini Oven

Case Pack 2

- Low Wattage • Stainless Steel • Compact Size
- Versatile • 60 Minute Timer • Baking plate
- Grill grid • Analogue control panel
- Double glass door • Removable Crumb Tray
- Size: 73.5 x 42.2 x 27 cm • Weight 3.3kg
- Capacity: 10ltr • Wattage: 650W

Cat No 037505
Quest Elite® Maxi Grill

Case Pack 3

- Premium Quality • Non Stick • Fold Out Tilt Clip
- Removable Drip Tray • Adjustable Temperature
- Removable Grill • Easy to Clean • Glass Lid
- Steam Escape • Size: 44 x 49 x 15 cm
- Grill Area: 36 cm • Weight: 3.4 kg
- Voltage : 220 - 240v • Wattage: 1300w



Cat No 047513
Quest Single Hot Plate

Case Pack 12

- Low Wattage • Lightweight • Portable
- Easy to Clean • Variable Temperature
- Overheat Cut Off • Weight: 1.4 kg
- Size: 22 x 22 x 7.5 cm • Hotplate: 18.5 cm
- Cord: 1m • Wattage: 1000w.

Cat No K0015
Double Hot Plate

Case Pack 12

- Lightweight • Easy Clean Surface • Portable • Thermostatic control • Overheat Cut Off
- Independant Temperature Controls • Hotplate Size: 15 (small) and 18.5cm (large)
- Total Size: 46 x 28 x 9 cm • Weight: 3.1 kg.
- Cord Length: 89cm
- Wattage: 500W (small hotplate), 750W (large hotplate) • Frequency : 50/60hz • Voltage: 220- 240v



Cat No 141002
Quest Flame Effect Ceramic heater

- Flame Effect • Low Wattage • Lightweight
- Portable • Ceramic Elements • Heat in the Winter
- Cool Air in the Summer • Tip Over Safety Cut Out
- Adjustable Heat • Carry Handle
- Size: 28 x 38 x 16 cm • Weight: 2.3 kg.



Cat No 047519 **Case Pack 6**
Quest by Tristar Ceramic Heater

- Lightweight • Portable • Ceramic Elements
- Heat in the Winter • Cool Air in the Summer
- Oscillating Function • Tip Over Safety Cut Out
- Adjustable Heat • Carry Handle
- Size: 16 x 14 x 23 cm • Weight: 1.3 kg.



Best for VALUE



Cat No 2091 **Case Pack 6**
Quest Dual Purpose Fan Heater

- Dual Purpose Fan Heater
- Adjustable Heat and Fan • Heat in the Winter
- Cool Air in the Summer • Whisper Quiet Fan
- Carry Handle • Overheat Shut Off • Lightweight
- Portable • Size: 20 x 25 x 13 cm • Weight: 1.1 kg
- Power: 1000w or 2000w



Cat No 141001 **Case Pack 6**
Quest Oil filled Radiator

- Low Wattage • 7 Fins • Adjustable Thermostat
- Overheat Protection • Power Indicator • Cord Storage
- Carry Handle • Stability Feet • Pressure tested for Additional Safety
- Weight: 4.15 kg • Size: 33 x 39 x 10 cm
- Cable Length: 140 cm • Power: 800w
- Voltage: 220-240v • Frequency: 50/60hz.



Cat No 028314 **Case Pack 6**
Large Oscillating Halogen Heater

- Low Wattage • Lightweight • Portable
- Adjustable Heat • Oscillates • Carry Handle
- Safety Tip Over Cut Out
- Size: 31.5 x 21 x 50 cm • Weight: 3 kg
- Power: 400w, 800w and 1200w.
- Voltage: 220-240v • Frequency: 50/60hz



Cat No 208414 **Case Pack 6**
Slimline Quartz Heater

- Slim line and Portable • Lightweight
- Adjustable Heat • Tip Over Safety Cut Out
- Cool Touch Body • Instant Heat • Carry Handle
- Size: 40 x 30 x 10 cm • Weight: 0.96 kg
- Power: 400w and 800w.
- Voltage: 220-240v • Frequency: 50/60hz



Cat No 7178
Quest Oil filled Radiator

- Piezo-Electric Ignition • 3 Different Heat Settings • Fast Heating
- Energy Saving • Flame Failure Protection Device • Oxygen Depletion Sensor
- Casters • Includes Hose and Regulator
- Gas Bottles up to 7 kg. • Size: 30 x 30 x 60 cm. • Weight: 7.5 kg.

Case Pack 6



Cat No 047179 **Case Pack 6**
Large Heatforce Portable Gas Cabinet Heater

- Piezo-Electric Ignition • 3 Different Heat Settings • Fast Heating
- Energy Saving • Flame Failure Protection Device • Oxygen Depletion Sensor
- Castors • Foldaway base plate • Includes Hose and Regulator
- Gas Bottles up to 15 kg. • Size: 74.5 x 42 x 49 cm. • Weight: 12.3 kg.

Case Pack 6

Cooling Range

Keeping your Items Cool

The Quest cooling range of products contains coolboxes and fridges that can be used in the camping, caravanning and leisure industries.

They are high quality products with a varied list of features that include multiple power sources, split lids, cooling and heating functions, low noise absorption systems and more.



Cat No 7501
Tristar 45 Litre 3 Way Chest Fridge

Case Pack 6

- Premium Quality • Piezo Ignition • Car, Mains and Gas Use
- Auto Switching • Large Capacity • Low Absorption System
- Cools more than 25 Degrees Below Ambient Temperature • Whisper Quiet
- Ice Cube Trays • Stainless Steel Housing
- Can be used with camping, propane or butane gas
- Capacity: 45 L • Weight: 18.5 kg
- Size: 55 x 51 x 50 cm • DC Cooling: 75 Watts • AC Cooling: 82.5 Watts.



Cat No 4871
33L Wheeled Portable Coolbox

Case Pack 6

- High Quality • Easy to Use and Move. • Dual Voltage. • Split Lid. • Wheeled.
- Cools and Heats. • Cools to 20 degrees centigrade below Ambient Temperature. • Heats to a maximum of 50 degrees centigrade
- Size: 56 x 37 x 46 cm. • Volume: 33L • Weight: 9 kg.



Cat No 157512
25L Fire Red Portable Coolbox

Case Pack 4

- Heats and Cools • Lightweight • Easy to Carry • Premium Quality
- Fold Away Handle • A++ Rating • Dual Voltage (12v or 240v)
- Built in Cable Tidy • Separator Shelf • Very Quiet Motor
- Size: 42 x 40 x 30 cm. • Weight: 3.8 kg. • Capacity: 25L • Decibels: 35 dB
- Cooling: 18 - 22°C below ambient temperature
- Heating: Warms to +65°C by set-point thermostat

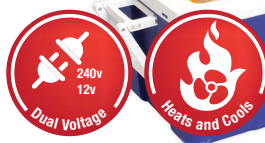

Cat No 157514
40L Cool Blue Wheeled Portable Coolbox

Case Pack 4

- Heats and Cools • Premium Quality • Fold Out Handle • Inbuilt Wheels
- A++ Rating • Dual Voltage (12v or 240v) • Built in Cable Tidy
- Separator Shelf • Very Quiet Motor
- Size: 56 x 29 x 42 cm. • Weight: 6.8 kg. • Capacity: 40L • Decibels: 35 dB
- Cooling: 18 - 22°C below ambient temperature
- Heating: Warms to +65°C by set-point thermostat





Cat No 7501S
Coolbox and Garden Fridge Stand

Case Pack 6

- Folds Away in Seconds • Stepless Levelling Leg
- Easy to Use and Store • 2 Different Sizes in One • Lightweight • Non Slip Padding
- Size: 40 x 50 x 42cm and 47 x 50 x 32 cm.
- Height 42 cm and 32 cm.
- Folded: 58 x 11 x 8 cm • Weight: 1.38 kg.



Cat No 133012
Handy Cooler Seat

Case Pack 6

- Both a foldaway seat and drinks cooler in one • Folds Away in Seconds
- Easy to Carry • Lightweight • Padded Seat • Large Internal Space
- Fully Insulated Inner • Capacity: 13.5L
- Can Hold: 14 bottles (500ml) or 26 cans (330ml) • Size: 30 x 30 x 29 cm
- Folded: 30 x 30 x 10 cm • Weight: 1.1 kg • Max Load (seat): 100 kg
- Max Load (carry): 10 kg.



Cat No 2060
Cordwheel

Case Pack 10

- High Quality • Versatile Storage Wheel • Multiple Uses • Extension Cords
- Soaker Hose • Rope and More
- Capacities: 110" - 12 gauge : 125" - 14 gauge : 150" - 16 gauge



Cat No 40011
Mains Awning and Camping Light

Case Pack 10

- Specifically designed for awnings and tents • Extra Long Mains Cable
- Hook connection • Clips for connection to poles
- Cable Length: 6 m • Light Size: 20 x 10 x 10 cm.

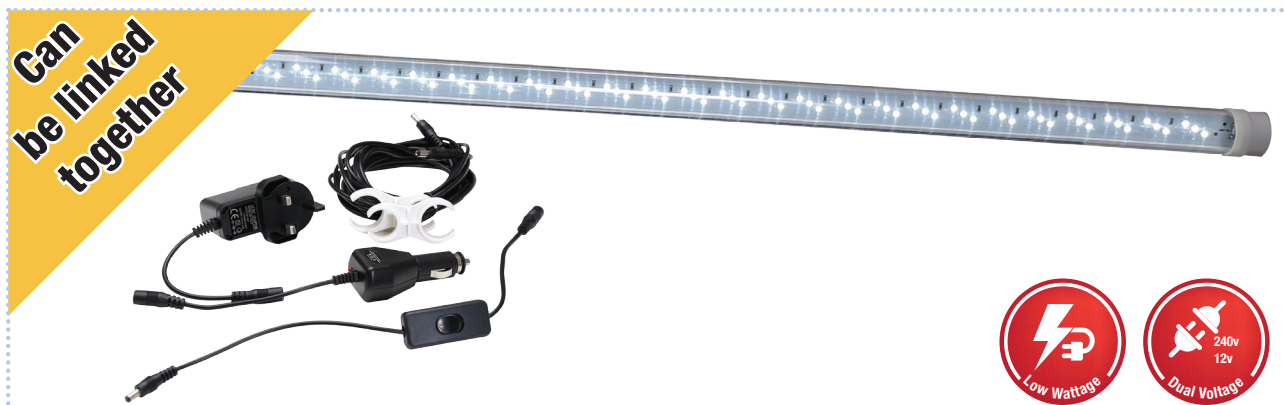

Cat No 154598
Quest Serial LED Light

Case Pack 12

- Great for awnings, tents, gazebos, sheds, playhouses and more. • Extra Bright LED's • Low Wattage • Multiple lights can be linked together.
- Can be used with or without the switch • Stays cool during use • Gives Out Excellent Light. • Dual Voltage. • 150 LED Lights. • Inline Switch.
- Consists of : 1 x 120 LED Light , 1 x Power Cable , 1 x 240v UK Mains plug , 1 x 12v Cigarette Lighter plug , 1 x Cable with inline switch , 2 x Pole Clips
- Voltage: 12v/240v. • Wattage: 11w • Frequency: 50/60 hz. • Light Length 120 cm. • Total Cable Length: 5m.
- Maximum Number of chained lights: 3 • Weight: 0.65kg

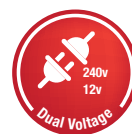

Kipor Generators

The best choice

KIPOR has the right generator to meet your power needs and they are the best choice in portable power.

Outstanding serviceability and reliable performance in a simple, easy-to-use design to make Kipor generators the best choice in portable power. Ideal for RV, Camping, Home Applications and many more.



All KIPOR generators delivery the following benefits

- Clean, high quality power
- Okay for even the most sensitive electronic equipment
- Lightweight
- Compact and Portable
- Low Noise Design
- Highly Fuel Efficient
- Environmentally friendly
- Automatic Overload Shutdown
- Automatically adjusting engine speed
- Superior Engine Performance
- Low Oil Level Protection

Cat No KIG770

Case Pack N/A

Kipor Generator IG770

- Max Output : 770w
- Fuel Capacity: 1.55 litres
- Running time (rated output): Approx 3 hrs
- Size: 415 x 220 x 360 mm
- Weight: 10.5 kg
- Noise Level: 65dBa at 7 metres



Cat No KIG1000P

Case Pack N/A

Kipor Generator IG1000P

- Max Output : 1000w
- Fuel Capacity: 2.6 litres
- Running time (rated output) Approx 3 hrs
- Size: 460 x 230 x 395 mm
- Weight: 14 kg
- Noise Level: 59dBa at 7 metres



Cat No KIG2000P

Case Pack N/A

Kipor Generator IG2000P

- Max Output : 2000w
- Fuel Capacity: 3.7 litres
- Running time (rated output): Approx 3 - 4 hrs
- Size: 515 x 300 x 430 mm
- Weight: 22 kg
- Noise Level: 73dBa at 7 metres



Cat No KIG2600P

Case Pack N/A

Kipor Generator IG2600P

- Max Output : 2600w
- Fuel Capacity: 5 litres
- Running time (rated output): Approx 3 hrs
- Size: 565 x 320 x 465 mm
- Weight: 29.5 kg
- Noise Level: 65dBa at 7 metres



Cat No KIG3000P

Case Pack N/A

Kipor Generator IG3000P

- Max Output : 3000w
- Fuel Capacity: 13 litres
- Running time (rated output): Approx 6.7 hrs
- Size: 684 x 440 x 505 mm
- Weight: 57 kg
- Noise Level: 63 - 73 dBa at 7 metres



Cat No KIG4000P

Case Pack N/A

Kipor Generator IG4000P

- Max Output : 4300w
- Fuel Capacity: 13 litres
- Running time (rated output): Approx 5 hrs
- Size: 785 x 470 x 570 mm
- Weight: 75 kg
- Noise Level: 63 - 73 dBa at 7 metres



Cat No KIG6000H

Case Pack N/A

Kipor Generator IG6000H

- Max Output : 6000w
- Fuel Capacity: 1.55 litres
- Running time (rated output): Approx 6 hrs
- Size: 1235 x 650 x 770 mm
- Weight: 98.3 kg
- Noise Level: 63 - 73 dBa at 7 metres



- **Thick-Grid Plate Technology with Glass Fibre Separators:** Increases electrical capacity and deep cycle capability
- **Labyrinth Lid Technology and Spark Arrestor:** Allows emissions to be safely exhausted externally from the caravan or motorhome with added protection against gas combustion within the battery
- **State of Charge Indicator:** Easy to use visual indicator to check the batteries charge and levels
- **Sealed for Life:** Maintenance free and spill proof
- **Dual Post Options:** For applications where multiple battery connections are required

Platinum Leisure Portable Power

This is the UK's best selling and best known brand of leisure batteries. It is getting stronger and stronger with more and more customers asking for it by name.

This range has been engineered to cope with continuous cycling, whilst delivering high performance and durable long-life for all caravan and motorhome applications.



Platinum Leisure Vented Batteries

• Battery Type: Wet open flooded • Terminal Type: Automotive Post • Voltage: 12 volts • Lifetime Cycles: 120 • Warranty: 2 Years

Case Pack 30

Cat No 4298:

Platinum Leisure 685L

• 75 Amps • Size (lwh): 267 x 172 x 222 mm • Total Height: 222 mm.

Cat No 4299:

Platinum Leisure Plus 6110L

• 110 Amps • Size (lwh): 267 x 172 x 222 mm • Total Height: 222 mm.



Platinum Leisure Sealed for Life Batteries (single post)

• Battery Type: Sealed for Life • Terminal Type: Automotive Post • Voltage: 12 volts • Lifetime Cycles: 120 • Warranty: 2 Years

Case Pack 30

Cat No 4298S:

Platinum Leisure S685L

• 75 Amps • Size (lwh): 258 x 172 x 200 mm • Total Height: 222 mm.

Cat No 4299S:

Platinum Leisure Plus S6110L

• 110 Amps • Size (lwh): 328 x 171 x 237 mm • Total Height: 237 mm.

Cat No 4299LB:

Platinum Leisure Plus LB6110L

• 110 Amps • Size (lwh): 351 x 174 x 188 mm • Total Height: 188 mm.



Platinum Leisure Sealed for Life Batteries (dual post)

• Battery Type: Sealed for Life • Terminal Types: Automotive Post and Threaded Stud • Voltage: 12 volts • Lifetime Cycles: 120 • Warranty: 2 Years

Case Pack 30

Cat No 4298SD:

Platinum Leisure SD685L

• 75 Amps • Size (lwh): 258 x 172 x 200 mm • Total Height: 222 mm.

Cat No 4299SD:

Platinum Leisure Plus SD6110L

• 110 Amps • Size (lwh): 328 x 171 x 215 mm • Total Height: 237 mm.

Cat No 4300SD:

Platinum Leisure Plus SD690L

• 90 Amps • Size (lwh): 302 x 170 x 200 mm • Total Height: 222 mm.

Platinum AGM

Longer Life Faster Charge

The brand new Absorbed Glass Mat range from Platinum batteries.

Platinum's AGM (Absorbed Glass Mat) sealed maintenance free batteries have a number of design features that delivery optimum performance, heavy duty cycling and extra long life beyond the Platinum Leisure and Leisure Plus range.

- **Heavy Duty Grid with Absorbed Glass Mat Separators:** Holds electrolyte like a sponge to prevent acid spillage and provides up to **5 times more cycles** than a standard leisure battery.
- **Advanced Plate Design:** High pur lead oxide gives extended life, high resistance to corrosion and reduces self-discharge.
- **Regulated Individual Cell Values:** To ensure optimum float and discharge performance.
- **Sealed Construction:** Unique construction ensures no electrolyte leakage from terminals or case.
- **Gas Regeneration:** Unique safety design recombines around 99% of the gas generated during normal usage.
- **Faster Recharge:** Reduced charging time compared to the Leisure and Leisure Plus range.



Cat No 4298AGM **Case Pack 30**
Platinum Leisure AGM Battery PAGM75-12

- Battery Type: AGM Sealed • Terminal Type: Female Thread
- Voltage: 12 volts • Ampage: 75 amps • Warranty: 2 Years • Box Size: 685
- Size (lwh): 260 x 169 x 210 mm • Total Height: 235 mm.



Cat No 4299AGM1 **Case Pack 30**
Platinum Leisure AGM Battery PAGM100-12

- Battery Type: AGM Sealed • Terminal Type: Female Thread
- Voltage: 12 volts • Ampage: 120 amps • Warranty: 2 Years • Box Size: 6110
- Size (lwh): 328 x 172 x 222 mm • Total Height: 222 mm.



Cat No 4299AGM2 **Case Pack 30**
Platinum Leisure AGM Battery PAGM120-12

- Battery Type: AGM Sealed • Terminal Type: Female Thread
- Voltage: 12 volts • Ampage: 120 amps • Warranty: 2 Years • Box Size: 6110
- Size (lwh): 328 x 172 x 222 mm • Total Height: 222 mm.



Cat No 4301AGM **Case Pack 30**
Platinum Leisure AGM Battery PAGM145-12

- Battery Type: AGM Sealed • Terminal Type: Female Thread • 12 volts
- 145 amps • Box Size: 6135C • Warranty: 2 Years
- Size (lwh): 340 x 173 x 285 mm • Total Height: 285 mm.



Cat No 4302AGM **Case Pack 30**
Platinum Leisure AGM Battery PAGM180-12

- Battery Type: AGM Sealed • Terminal Type: Female Thread • 12 volts
- 180 amps • Box Size: 6180 • Warranty: 2 Years
- Size (lwh): 530 x 209 x 214 mm • Total Height: 214 mm.

- **Trojan Grid Plate Technology:** Trojans grid technology is a lead antimony alloy grid mixture which provides enhanced power.
- **Maxguard T2 Separator:** Provides greater strength resulting in a longer battery life.
- **Alpha Plus Paste™ with T2 Technology:** Giving you the maximum operating performance possible.
- **Robust Plates:** Extends the life of your battery and gives up to 10 times more cycles.
- **Glass Fibre Separators:** Act as a blotter to absorb the electrolyte, increasing cyclic ability.

Trojan The Ultimate Power

Since 1925, the Trojan battery company has been engineering the most reliable, long lasting, deep-cycle batteries available. Specifically designed to meet the demands of the most serious leisure enthusiast.

The Trojan range feature faster recharge times, longer life and extremely high cycle rates, giving you the ultimate in portable power solutions

- **Low Calcium Grid Alloy:** Reduces gas emissions and improves flame arresting.
- **Exclusive Gel Formulation:** Delivers consistent performance and reliability.
- **Premium Graded, Double Insulated Separators:** Allows maximum charge flow between plates for optimum performance.
- **Up to 10 Times Longer Life:** The Trojan batteries have up to 10 times longer life span than Platinum Leisure and Leisure plus batteries.
- **Up to 5 times more cycles:** The Trojan batteries have up to 5 times more cycles than Platinum Leisure and Leisure plus batteries.
- **Heavy Duty:** A true heavy duty, extremely durable battery.
- **Deep Cycle:** A true deep cycle, extremely long life, high cyclic battery.
- **Patented Design Components:** Deliver superior power for the serious leisure enthusiast where nothing but the best will do.



Cat No 4298TJ150 **Case Pack 30**
Trojan Deep Cycle Battery SCS150-DWNT (685)

- Battery Type: Trojan Vented Deep Cycle • Volts 12v • Amps: 100a
- Terminal Type: Automotive Post and Threaded Stud
- Warranty: 2 Years • Box Size: 685
- Size (lwh): 286 x 171 x 207 mm • Total Height: 248 mm.



Cat No 4299TJ225 **Case Pack 30**
Trojan Deep Cycle Battery SCS225-DWNT (6110)

- Battery Type: Trojan Vented Deep Cycle • Volts 12v • Amps: 130a
- Terminal Type: Automotive Post and Threaded Stud
- Warranty: 2 Years • Box Size: 6110
- Size (lwh): 355 x 171 x 207 mm • Total Height: 248 mm.



Cat No 4300TJ200 **Case Pack 30**
Trojan Deep Cycle Battery SCS200-DWNT (690)

- Battery Type: Trojan Vented Deep Cycle • Volts 12v • Amps: 115a
- Terminal Type: Automotive Post and Threaded Stud
- Warranty: 2 Years • Box Size: 690
- Size (lwh): 324 x 171 x 207 mm • Total Height: 248 mm.

Platinum AGM

Longer Life Faster Charge

The Giant Leisure range is a comprehensive range of batteries which all benefit from thick grid plates for improved deep cycling capability and envelope separation for a longer life

- Thick Grid Plates
- Deep Cycling Capability
- Envelope Separation



Cat No 4298UKG
UK Giant Power Pack 685L

Case Pack 30

- Battery Type: Wet Open Flooded • Terminal Type: Auto Post • Volts: 12v
- Amps: 75a • Warranty: 2 Years. • Box Size: 685
- Size (lwh): 267 x 172 x 222 mm • Total Height: 222 mm



Cat No 4299UKG
UK Giant Power Pack 6110L

Case Pack 30

- Battery Type: Wet Open Flooded • Terminal Type: Auto Post • Volts: 12v
- Amps: 110a • Warranty: 2 Years. • Box Size: 6110
- Size (lwh): 350 x 175 x 225 mm • Total Height: 225 mm.



Cat No 4299LBUKG
UK Giant Power Pack LB6110L

Case Pack 30

- Battery Type: Wet Open Flooded • Terminal Type: Auto Post • Volts: 12v
- Amps: 100a. • Warranty: 2 Years. • Box Size: 6110 (low box)
- Size (lwh): 351 x 174 x 88 mm • Total Height: 188 mm.



Cat No 4298SDUKG
UK Giant Sealed for Life Dual Post Power Pack 685L

Case Pack 30

- Battery Type: Sealed for Life • Terminal Type: Auto Post and Stud
- Volts: 12v • Amps: 75a • Warranty: 2 Years. • Box Size: 685
- Size (lwh): 258 x 172 x 200 mm • Total Height: 222 mm



Cat No 4299SDUKG
UK Giant Sealed for Life Dual Post Power Pack 6110L

Case Pack 30

- Battery Type: Sealed for Life • Terminal Type: Auto Post and Stud
- Volts: 12v • Amps: 110a • Warranty: 2 Years. • Box Size: 6110
- Size (lwh): 328 x 171 x 215 mm • Total Height: 237 mm.



Cat No 1188W
Clipper Wave Gas Flame Lighter

Case Pack 12

- The next generation of gas lighters • Larger Capacity
- Easy to See Fill Level • Adjustable Flame • Safer than matches
- Display box of 12. (4 assorted colours) • Colours: Black, White, Red, Blue
- Gas: Butane • Size: 28 x 5 x 2 cm.



Cat No 1186C
Clipper Tube Lighter

Case Pack 12

- Easy to Use • Safer than matches
- 4 Assorted colours in a display box of 12. Colours: Black, White, Red, Blue
- Gas: Butane • Size: 19 x 3 x 2cm.



Cat No 1184
Clipper Gas Refil 250ml

Case Pack 12

- Universal Butane Gas Refil Canister
- Fills all major lighter brands fast and efficiently



Cat No 7174
Butane Gas Cartridge (Pack of 4)

Case Pack 7

- Great value • 4 pack • 220g Butane Gas Cartridges



Cat No 7150
Orange Hose 50M

Case Pack 3

- BS3212 Type 2 • Orange.
- Maximum working pressure of 17.5 bar.
- 8.0mm 5/16" bore 15mm o.d.

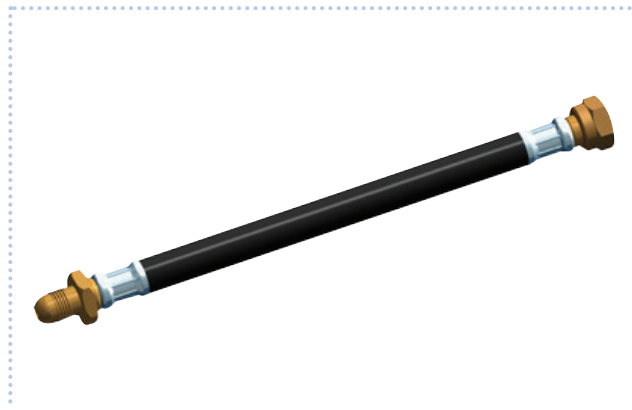

Cat No 7162
Excess Flow Hose Assembly

Case Pack 10

- 20 inch Handwheel POL Excess Flow • W20 Hose Assembly
- Size: 45 cm.



Cat No 7151
21mm Clip On Regulator

- 21mm Clip on Butane Regulator • Capacity 1kg/hr
- Max inlet pressure 7.5bar • Operating pressure 2829mbar
- Nozzle outlet to suit 8mm ID hose • Approved to EN128642001

Case Pack 10

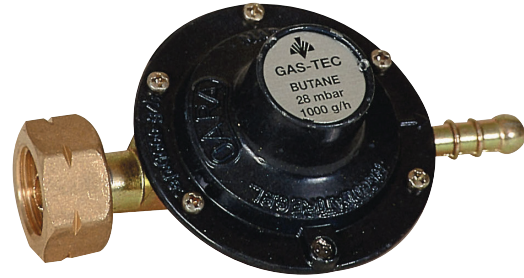

Cat No 7152
Low Pressure Butane Regulator

- Capacity 1kg/hr • Max inlet pressure 7.5bar
- Operating pressure 2829mbar • Inlet 21.8LH female
- Nozzle outlet to suit 8mm ID hose • Approved to EN128642001.

Case Pack 10



Cat No 7153
Gaz Regulator

- CampinGaz butane regulator • Reinforced Diaphragm. • Capacity: 1kg/hr.
- Inlet: Campingaz screw in • Max Inlet Pressure: 7.5bar.
- Operating Pressure: 29mbar. • Nozzle outlet to suit 8mm ID hose.
- Approved to EN12864:2001

Case Pack 10



Cat No 7154
Propane Regulator

- Capacity 1.5kg/hr • Max Inlet pressure 20bar
- Operating pressure 37 mbar or 50 mbar • Inlet Male UK Pol 5/8 BSP
- LH Nozzle outlet to suit 8mm ID hose.
- Approved to EN128642001.

Case Pack 10

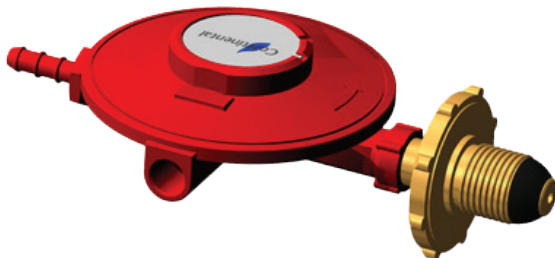

Cat No 7168
Quick Release Propane Regulator

- Capacity 1.5kg/hr • Max inlet pressure 20bar
- Operating pressure 37mbar • Inlet Male UK POI 5/8.
- LH Handwheel Connection Nozzle outlet to suit 8mm ID hose.
- No spanner required.

Case Pack 10



Cat No 7161
Excess Flow Hose Assembly

- 20 inch POL Excess Flow • W20 Pigtail Hose Assembly
- POL Size: 50 cm.

Case Pack 10



Caravan Covers

Case Pack 2

- Breathable • Dual Zips • Durable • Strong • Reinforced Straps • Storage Bag • UV Stable • Heavy Duty • Water Resistant • Long life • Tailored Fit
- Material: Heavy duty 3 ply non-woven polypropylene • Width: 230cm (7ft 8) • Length: (see below) • Weight: 6 - 11 kg.

Cat No: 4342K: 360 - 420 cm (12 - 14 feet)
Cat No: 4343K: 420 - 510 cm (14 - 17 feet)

Cat No: 4344K: 510 - 570 cm (17 - 19 Feet)
Cat No: 4345K: 570 - 630 cm (19 - 21 Feet)

Cat No: 4346K: 630 - 690cm (21 - 23 Feet)
Cat No: 4347K: 690 - 750 cm (23 - 25 Feet)

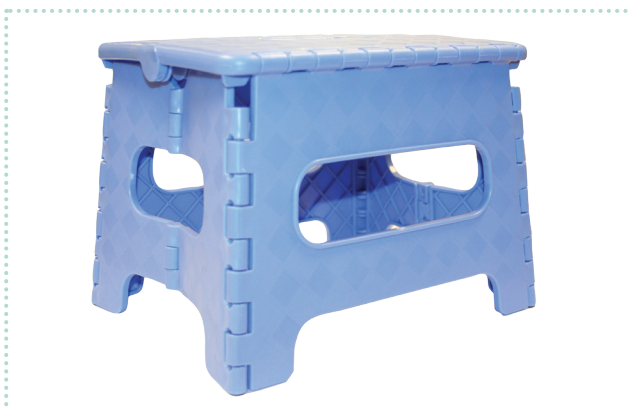

Cat No 047182
Foldable Step

Case Pack 6

- Folds Away • Lightweight • Portable • Handle • Weatherproof
- Easily Stored Away • Tested to EN1728 standard
- Size: 30 x 22 x 22 cm • Folded: 3 x 30 x 32 cm
- Weight: 810g • Max Load: 100kg.



Cat No 047181
Double Step

Case Pack 6

- Lightweight • Cream Powder Coated Frame • Anti-Slip Rubber Top on Step
- Rubber feet • Extremely Solid Construction • Anti-Sink Bars
- Step Heights: 25 and 38cm.
- Size: 65 x 44 x 38 cm • Weight: 3.5 kg



Cat No 4739
Large Clingons

Case Pack 12

A display box of large clingons. The moveable, reusable, instant eyelet. Each display box has 8 packs in. Each pack has 4 clingons in. They come in two assorted colours, white and blue.



Cat No 107050
Bag of 10 Green Plastic Eyelets

Case Pack 25

- Universal • Easy to Use • Plastic Eyelets
- For Use on Canvas or plastic sheeting.



Multi-Fit Roof Bars

Case Pack 2

- Easy to Fit • Easy to Use • Durable
- See application guide for vehicle fitting and exact model number (url below)

- Cat No:** QSUM-101: **Series 100 Model 101**
- Cat No:** QSUM-104: **Series 100 Model 104**
- Cat No:** QSUM-105: **Series 100 Model 105**
- Cat No:** QSUM-107: **Series 100 Model 107**
- Cat No:** QSUM-108: **Series 100 Model 108**
- Cat No:** QSUM-201: **Series 200 Model 201**
- Cat No:** QSUM-203: **Series 200 Model 203**
- Cat No:** QSUM-204: **Series 200 Model 204**
- Cat No:** QSUM-303: **Series 300 Model 303**



Steel Railing Roof Bars

Case Pack 2

- Durable • Easy to Fit • Easy to Use
- See application guide for vehicle fitting and exact model number (url below)

- Cat No:** QSUM-500: **Series 500 Model 500**
- Cat No:** QSUM-501: **Series 500 Model 501**
- Cat No:** QSUM-520: **Series 500 Model 520**
- Cat No:** QSUM-521: **Series 500 Model 521**



Aluminium Railing Roof Bars

Case Pack 2

- Lightweight • Durable • Easy to Fit • Easy to Use
- See application guide for vehicle fitting and exact model number (url below)

- Cat No:** QSUM-522: **Series 500 Model 522**

Online Application guide for roof bar, vehicle fitting and full list of all available model numbers

<http://www.mountneyltd.com/catalog/leisure/category/146>



Gloss Black Roof Boxes

- Easy to Fit • Easy to Use • Durable • 3 Different Sizes • Easily opened • Securely lockable • Tough • Aerodynamic • U-bolts Mounts (included)
- Mounts onto your existing roofbars.

320L Dimensions: • Capacity: 320 Litres • Size: 132 x 78 x 36 cm. • Weight: 14kg • Max load: 50kg • 2 Point Locking

430L Dimensions: • Capacity: 430 Litres • Size: 180 x 78 x 40 cm. • Weight: 18kg • Max load: 50kg • 3 Point Locking

530L Dimensions: • Capacity: 530 Litres • Size: 180 x 94 x 39 cm. • Weight: 25kg • Max load: 75kg • 3 Point Locking

Cat No QUE-320MB **320L Roof box**

Cat No QUE-430MB **4300L Roof box**

Cat No QUE-530MB **530L Roof box**

Case Pack 2

Case Pack 2

Case Pack 2



Scan me to check fitting



Cat No 051196
Table Top Ironing board

- Medium Sized • Folds Out and Away • Easy to Store
- Removable and Washable Cover • Slide out Iron Stand
- Legs Lock into Position • Folds Flat When Not In Use
- Size: 74 x 18 x 30cm • Folded: 74 x 18 x 6cm.
- Weight: 1.7kg.

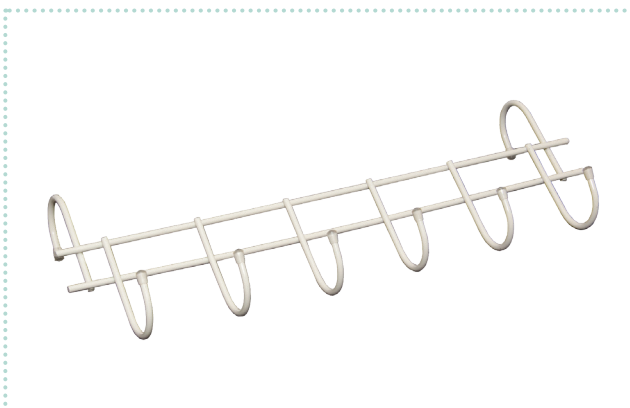

Case Pack 6 **Cat No** 031205
6 Hook Multi-Hanger

- Simply Hooks into Place • Lightweight • Easy to Use • Strong
- Universal Use • 6 Hanging Hooks
- Cream Powder Coated Frame
- Size: 39 x 14 x 6cm.



Cat No 031204 **Case Pack** 12
Quest Clothes Hangers 5pc set

- 8 Non slip coated hangers • Non Slip Coating
- Cut Out for Hanging Loops.



Cat No 1193 **Case Pack** 5
Caravan Drying Rack

- Lightweight • Easy to Use • Strong
- Large Drying Area • Simply Hooks into Place
- Frame: Plastic Coated Steel • Drying Area: 7m



Cat No 4505 **Case Pack** 4
Rotary Airing Stand

- Premium Quality • 4 Arms • Lightweight • Portable • Includes Pegging Points and Pegs
- Folds Away for Easy Storage • Adjustable Arms • Complete with Carry Bag
- Frame: Aluminium • Weight: 2.4 kg • Size: 135 x 135 x 140 cm

Mats and Matting

Great Range, Great value

This is the Quest Leisure range of mats and matting. We have a wide range of flooring available ranging from simply rimini mats though to large rolls of quest tex lite.

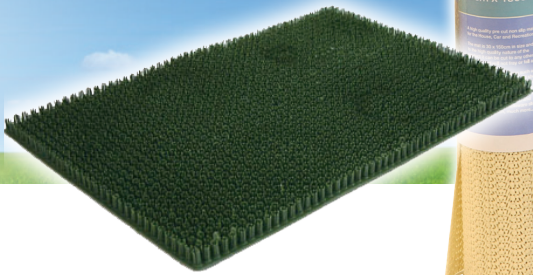

Cat No 6739
Rimini Runner 57 x 150cm

- Machine Washable • Bound Edge • Soft latex Backing • Easy to Maintain
- Protects all types of Flooring • 100% Polypropylene Pile
- Size: 57 x 150 cm.

Case Pack 12

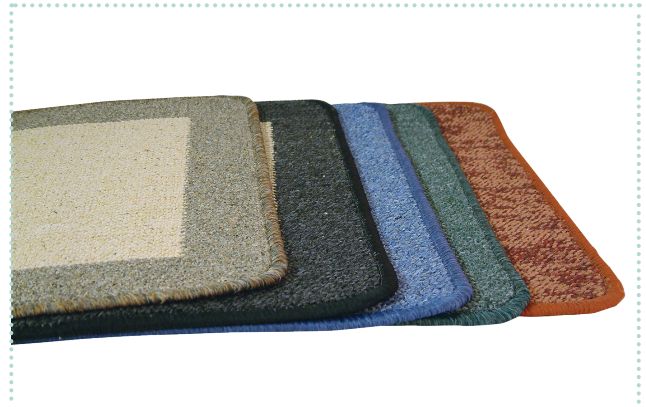

Cat No 6738
Rimini Door Mat 40 x 57cm

- Machine Washable • Bound Edge • Soft latex Backing • Easy to Maintain
- Protects all types of Flooring • 100% Polypropylene Pile
- Size: 40 x 57 cm.

Case Pack 24



Dirt Stopper Harmony Assorted

- Absorbent mat with good scraper qualities. • Highly absorbent
- Fast Drying • Machine washable • Slip resistant backing
- Easy to maintain • Protects all types of flooring. • Indoor use only
- 70% cotton, 30% polyester pile.

Cat No 6722 40 x 60cm
Cat No 6723 50 x 80cm

Case Pack 12



Admiral Washable Non Slip Barrier Mat

- Absorbent mat with good scraper qualities. • Highly Absorbent
- Fast Drying • Machine washable • Protects all types of flooring
- Slip Resistant Flexible PVC Backing • Easy to maintain • Indoor use only
- 100% Cotton pile.

Cat No 6725 50 x 80cm
Cat No 6726 60 x 90cm

Case Pack 12



Cat No 4701c **Case Pack 48**
Non Slip Matting 30cm x 150cm

- High Quality • Multiple Uses • Non Slip Matting
- Can be Cut to Any Size • Does not Fray
- Protected Cushioned Surface
- Size: 30cm x 150cm

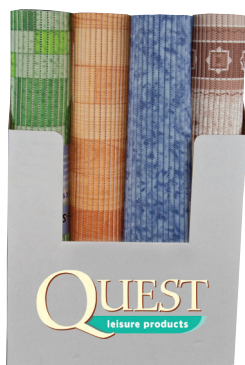

Cat No 4766 **Case Pack 12**
Quest Comfortex 65cm x 150cm Rolls

- Suitable for indoor or outdoor use • Easy to Use
- Easy to clean • Hard wearing • Non slip
- Ideal for bathrooms, kids play areas, Shower rooms, swimming/paddling pool areas.
- 6 Designs • Display case of 12

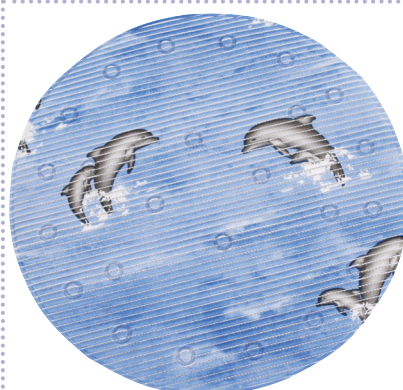

Cat No 055001 **Case Pack 12**
Quest 55cm Round Non Slip Mat

- High Quality • Underside Suckers
- Non slip even in wet areas • Soft and Durable
- Comfortable on Your Feet • Easy to Clean
- Long Lasting • Water Drains Away Easily
- Rolls away for easy storage
- Size: 55cm diameter



Carpet Guard

- Protects Carpets and other types of flooring • Heavy Duty Plastic
- Easy to Use • Extremely Durable • No Slip Backing
- Protects against wear damage and dirt • 67.5cm wide

Cat No 6720 : 30m Roll
Cat No 6721 : 1.7m Precut Size



Stik 'n' Guard

- Protects Carpets and other types of flooring • Easy to Use
- Extremely Durable • Self Adhesive Backing
- Protects against wear damage and dirt • 60 cm wide

Cat No 6718 : 10m Roll
Cat No 6724 : 100m Roll



Cat No 6727 **Case Pack 12**
Quest Caravan Door Mat

- High Quality • Durable • Outdoor Welcome Mat
- Caravan design. • Extremely Tough
- Great Scraper Qualities • Tough PVC Backing
- Can be used indoors and out.
- Size: 49 x 36 cm.

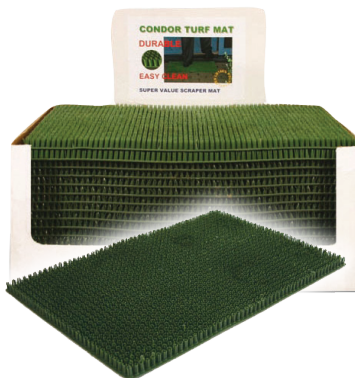

Cat No 6737d **Case Pack 1**
Condor Turf Mat 40 x 60cm

- Easy to Use • Easy to Clean • Extremely Durable
- Extremely Tough • Green Grass Effect
- Simply hose the mat when dirty
- Display Box of 25



Cat No 6713 **Case Pack 12**
Calder Carpet Runner 180 x 61cm

- Medium Weight • Domestic Runner • Attractive Narrow Rib Design.
- 100% polypropylene pile.

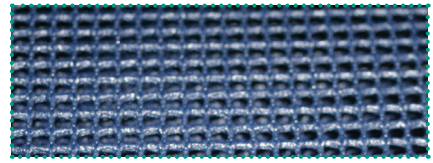
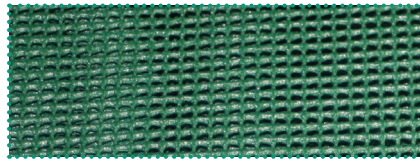
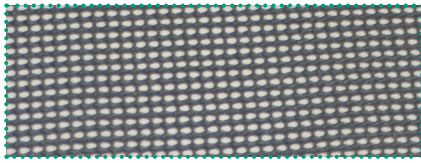

QUESTLITE

Questlite is an extremely hard wearing, fully breathable, luxurious feeling flooring. It comes in rolls or precut sizes and you can cut it to your own size and shape.

- Lightweight • Versatile • Extremely Durable
- Lasts for Years • Cushioned • Breathable
- Can be used Indoors and Out
- Can be used Wet or Dry • Rot Proof
- UV Resistant
- Can be Cut to Any Size and Shape
- Does not Fray • Does not Stretch
- Sealed Against moisture damage



Green Questlite Pre-Cut Sizes

Pre cut - ready to use Quest Lite luxury flooring

Code	Size (cm)
053101	250 x 200
053103	250 x 300
053104	250 x 360
053106	250 x 480
053109	250 x 660

Questlite Ready to Cut Complete Rolls

These are ready to cut to size rolls of Questlite luxury flooring. Each roll is 2.5m wide and 30m long.

Code	Colour
053006	Grey
053007	Green
053009	Blue



TREADLITE

Treadlite is a very hard wearing, breathable weaved flooring. It comes precut and is hemmed for extra strength. It has a dense weave so even though it is breathable it does not allow insects or worms through.

- Lightweight • Very Durable • Dense Weave
- Breathable • Can be used Indoors and Out
- Can be used Wet or Dry • Rot Proof
- UV Resistant • Folds Away Flat
- Pegging Eyelet in each corner



Treadlite Carpet

Pre packed and ready to go

Code	Size (cm)
0533	250 x 250
0534	300 x 250
0535	350 x 250
0536	400 x 250

Code	Size (cm)
0537	450 x 250
0538	500 x 250
0539	550 x 250
0540	600 x 250
0541	650 x 250
0542	700 x 250
0543	750 x 250

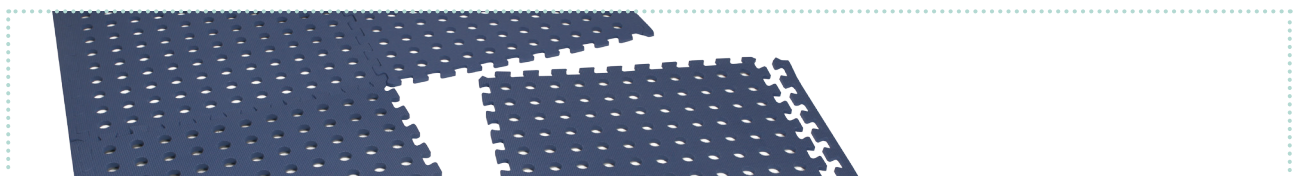

FLOORLITE

Treadlite is a very hard wearing, breathable weaved flooring. It comes precut and is hemmed for extra strength. It has a dense weave so even though it is breathable it does not allow insects or worms through.

- Lightweight • Versatile • Quick Locking
- Cushioned • Breathable
- Used Indoors or Out • 4 Tiles Per Pack
- 8 Edging Pieces Per Pack
- UV Resistant • Rot Proof • Packs Away



Cat No 0544

Floorlite Universal Floor Tiles

Case Pack 8

- Lightweight • Versatile • Quick Locking • Cushioned • Breathable • Used Indoors or Out
- 4 Tiles Per Pack • 8 Edging Pieces Per Pack • UV Resistant • Rot Proof • Packs Away

• Material: EVA Foam • Tile Size: 60 x 60 cm. • Coverage: 120 x 120 cm • Tile Thickness: 15 mm



Sleeping Bags

Luxury all year round

The Quest range of sleeping bags are an excellent range of luxury sleeping bags that can be used all year round.

They offer premium quality materials which not only work well, but are nice to the touch and look great.

They feature 2 way zips which allow you to have extra ventilation on those hot days and autolocking non snag zips. They come complete with compression bags.



Cat No 152014 **Case Pack** 6
Quest Lakeside Range Caramel Check Sleeping Bag

- High Quality • Washable • Luxury Soft Touch Outer and Inner • Zip Baffles
- Compression Bag • Oversized Bag • All Year Use • Anti Snag 2 Way Zips
- Internal Pocket • Premium Zip Pulls • Anti-Snag Zip Defender
- Can be zipped together with another bag to make oversized double bag

• Outer and Inner Shell: Polymicro • Filling: Hollowfibre • Filling Weight: 60 oz
• Size: 198 x 91 cm • Folded: 45 x 25 x 25 cm • Weight: 2.9 kg.



Cat No 152015 **Case Pack** 6
Quest Lakeside Range Aqua Check Sleeping Bag

- High Quality • Washable • Luxury Soft Touch Outer and Inner • Zip Baffles
- Compression Bag • Oversized Bag • All Year Use • Anti Snag 2 Way Zips
- Internal Pocket • Premium Zip Pulls • Anti-Snag Zip Defender
- Can be zipped together with another bag to make oversized double bag

• Outer and Inner Shell: Polymicro • Filling: Hollowfibre • Filling Weight: 52 oz
• Size: 198 x 91 cm • Folded: 45 x 25 x 25 cm • Weight: 2.9 kg



Cat No 112010 **Case Pack** 6
Ontario Sleeping Bag

- High Quality • Washable • Luxury Soft Touch Outer and Inner • Zip Baffles
- Compression Bag • Extra Large Bag • All Year Use • Anti Snag 2 Way Zips
- Can be zipped together with another bag to make extra large double bag

• Outer and Inner Shell: Polymicro • Filling: Hollowfibre • Filling Weight: 52 oz
• Size: 98 x 200 cm. • Folded: 56 x 38 x 38 cm • Weight: 3.7 kg.



Cat No 112011 **Case Pack** 6
Cascade Sleeping Bag

- High Quality • Washable • Luxury Soft Touch Outer and Inner • Zip Baffles
- Compression Bag • Oversized Bag • All Year Use • Anti Snag 2 Way Zips
- Can be zipped together with another bag to make oversized double bag

• Outer and Inner Shell: Polymicro • Filling: Hollowfibre • Filling Weight: 52 oz
• Size: 83 x 191 cm. • Folded: 50 x 35 x 35 cm • Weight: 2.7 kg.



Cat No 101091 **Case Pack** 6
Quest Lakeside Range Dots Sleeping Bag

- High Quality Oversized Sleeping Bag • Washable • Compression Bag
- All Year Use • Anti Snag 2 Way Zips • Zip Baffles • Can be zipped together with another bag to make oversized double bag
- Outer and Inner Shell: Polymicro • Filling: Hollowfibre • Weight: 2.7 kg
- Size: 198 x 91 cm • Folded Size: 45 x 25 x 25 cm • Filling Weight: 52oz



Cat No 101095 **Case Pack** 6
Quest Lakeside Range Fleur Sleeping Bag

- High Quality Oversized Sleeping Bag • Washable • Compression Bag
- All Year Use • Anti Snag 2 Way Zips • Zip Baffles • Internal Pocket
- Can be zipped together with another bag to make oversized double bag
- Outer and Inner Shell: Polymicro • Filling: Hollowfibre • Weight: 2.9 kg
- Size: 198 x 91 cm • Folded Size: 45 x 25 x 25 cm • Filling Weight: 60oz



Cat No 101099 **Case Pack** 6
Quest Lakeside Range Maple Leaf Sleeping Bag

- High Quality Oversized Sleeping Bag • Washable • Compression Bag
- All Year Use • Anti Snag 2 Way Zips • Zip Baffles • Internal Pocket
- Can be zipped together with another bag to make oversized double bag
- Outer and Inner Shell: Polymicro • Filling: Hollowfibre • Weight: 2.7 kg
- Size: 198 x 91 cm • Folded Size: 45 x 25 x 25 cm • Filling Weight: 52oz



Cat No 1097 **Case Pack** 6
Quest Lakeside Range Willow Leaf Sleeping Bag

- High Quality Oversized Sleeping Bag • Washable • Compression Bag
- All Year Use • Anti Snag 2 Way Zips • Zip Baffles • Internal Pocket
- Can be zipped together with another bag to make oversized double bag
- Outer and Inner Shell: Polymicro • Filling: Hollowfibre • Weight: 2.7 kg
- Size: 198 x 91 cm • Folded Size: 45 x 25 x 25 cm • Filling Weight: 52oz



Cat No 112009 **Case Pack** 6
Quest Lakeside Range Coniston Sleeping Bag

- High Quality Oversized Sleeping Bag • Washable • Compression Bag
- Luxury Soft Touch Outer and Inner • Zip Baffles • All Year Use
- Anti Snag 2 Way Zips • Internal Pocket
- Can be zipped together with another bag to make oversized double bag
- Outer and Inner Shell: Polymicro • Filling: Hollowfibre • Weight: 2.9 kg
- Size: 92 x 198 cm • Folded: 40 x 30 x 45 cm • Filling Weight: 60 oz



Cat No 4022 **Case Pack 10**
Ultra Soft Toilet Rolls

- Ultra soft tissue • Dissolves fast • Great Value
- 100% biodegradable • "No clog" performance
- Comes in a box of 10 x 4 packs



Cat No 4103 **Case Pack 12**
Blue Bags (tub of 18)

- Water soluble sachets
- Easy to Use • Convenient • Easy to Store
- Trusted Worldwide



Cat No 4110 **Case Pack 8**
Superkem 2ltr Fluid and Rinse (8)

- Easy to Use • Convenient • Trusted Worldwide



Elsan Blue Fluid

Recommended for all users of portable, cassette and pump out toilet systems in boats, caravans and motorhomes. It is pleasantly perfumed, and ensures safe and hygienic treatment.

Cat No 4101 2 Litre (8) **Case Pack 8**
Cat No 4104 4 Litre (8) **Case Pack 8**



Cat No 4107 **Case Pack 8**
Elsan Grey waste Tank Fresh 2 Litre

Add a little Elsan Tank Fresh to your water drains to get rid of stale odours. And used regularly, Tank Fresh also dissolves grease buildup.



Cat No S4109 **Case Pack 8**
Elsan 2L Organic Toilet Fluid + Free Toilet Bowl Cleaner 750ml

- No chemical smell • Fragranced • Toilet Rinse
- Can be used in both flush and waste tanks
- Biodegradable • Environmentally safe • Smear Free
- Eliminates odours • Helps Against Freezing



Cat No 4106 **Case Pack 8**
Elsan Pink Rinse 2 Litre (8)

Elsan Pink has a delightful fragrance that is automatically released every time the toilet is flushed. It is also antibacterial and keeps your flush tank clean and free from harmful bacteria without the need for additional additives.



Elsan Double : 'Double the Strength - Double the Dose'

The double concentrated Double Range has real advantages over standard toilet fluids. Precious storage space can be kept to a minimum and, because it lasts twice as long it provides exceptional value. The Elsan Double Range is non staining and is suitable for all chemical toilets and cassettes.

Cat No 4105 **2L Double Blue and 2L Double Rinse**
Cat No 4135 **400ml Double Rinse**
Cat No 4137 **400ml Double Blue**

Case Pack 8
Case Pack 24
Case Pack 24





Adhesive Backing Hooks (square)

Case Pack 10

- High Quality • Adhesive Backing • Square Back • Qty: 4 or 2 (See below) • Hook: Plastic • Colour: White or beige (see below)

- Cat No 5304 Small Square White Hooks (4)**
- Cat No 5305 Small Square Beige Hooks (4)**
- Cat No 5306 Large Square White Hooks (2)**
- Cat No 5307 Large Square Beige Hooks (2)**



Adhesive Backing Hooks (Round or Oval)

Case Pack 10



Cat No 5308

Small White Cup Hooks (4)

Case Pack 10

- High Quality • Adhesive Backing • Round or Oval Back • Qty: 3 or 2 (See below) • Hook: Plastic
- Colour: White or beige (see below)

- Cat No 5300 Small Round White Hooks (3)**
- Cat No 5302 Large Oval White Hooks (2)**
- Cat No 5303 Large Oval Beige Hooks (2)**

- High Quality • Adhesive Backing
- Square Back • Qty: 4 • Hook: Plastic
- Colour: White



Cat No 5313 Handy Clip White

Case Pack 12



Cat No 5309 White Suction Hook

Case Pack 10



Cat No 5310 White Single Towel Holder

Case Pack 10

- High Quality • Handy Clip on Front
- Adhesive Backing • Square Back
- Hook: Plastic • Colour: White.

- High Quality • Suction Cup Fitting
- Round Back • Reusable • Hook: Plastic
- Colour: White.

- Single "rubber sucker" type towel holders in white and self adhesive pad.
- Does not require screws or fittings
- Size: 40mm diameter

Fenwicks Superior Performance

Fenwicks are a British company who have been producing some of the best cleaning products available today.

Their products are made in the UK to the very highest of standards and surpass their rivals in performance and ease of use.

Superior performance, and proud to be made in the UK.



Cat No P0004
Caravan Cleaner Concentrate 1L

Case Pack 10

- Easy to Use • Cleans all Caravan Surfaces
- Removes Stubborn Streak and Algae
- Leaves sparkling bodywork and windows
- Safe for use on all caravan surfaces • Guaranteed Results.
- Volume: 1 Litre



Cat No P0005
Bobby Dazzler 1L

Case Pack 10

- Protective coating, with a dazzling shine
- Actively repels water, dirt and algae
- Easy to apply • No polishing necessary
- Safe for use on cars, caravans & motorhomes.
- Volume: 1 Litre



Cat No P0006
Over Wintering 1L

Case Pack 10

- Protective coating for the winter months
- Repels dirt, algae growth and black streaks
- Long lasting coating • Makes spring cleaning easier
- Safe for use on caravans & motorhomes
- No need to remove before using your caravan or motorhome.
- Volume: 1 Litre

Fenwicks

Superior Performance

Fenwicks are a British company who have been producing some of the best cleaning products available today.

Their products are made in the UK to the very highest of standards and surpass their rivals in performance and ease of use.

Superior performance, and proud to be made in the UK.



Cat No P0007
Black Streak Remover 1L

Case Pack 10

- Removes stubborn black streaks and algae
- Leaves sparkling finish • Quick and easy cleaning
- Ideal for use on caravans & motorhomes
- Can be used on arrival on site for waterless spot cleaning of travel grime.
- Volume: 1 Litre



Cat No P0008
Windowize 100ml

Case Pack 10

- Plastic and acrylic scratch remover
- Quick and effective
- Instantly enhances appearance
- Ideal for use on caravans and motorhomes
- Volume: 100ml



Cat No P0009
Awning and Tent Cleaner 1L

Case Pack 10

- For use on synthetic & cotton materials
- Removes stubborn streaks and algae
- Easily cleans awning & tent surfaces
- Ideal preparation for use with Fenwick's Re-proofer
- Can be used on cabriolet hoods
- Volume: 1 Litre



Cat No P0010
Awning and Tent Re-proofer

Case Pack 10

- Easy use on all synthetic & cotton materials
- Effectively waterproofs awning & tent surfaces
- Water based • Solvent free
- Ideal for use with Fenwick's awning and tent cleaner
- Can be used on cabriolet hoods and as a fabric stain guard
- Volume: 1 Litre



Cat No C002 **Case Pack 12**
Neilsen 2M Extending Deluxe Wash Brush

- Extendable • Easy to Use • Ergonomic Comfort Grips • Aluminum Handle
- Does not Scratch • Connects to your hose • Cut off tap on the handle
- Rust Proof • Twist Lock Handle
- Brush: Soft PVC • Tube: 25mm • Handle Length 1.2 - 2m
- Brush Head: 25cm



Cat No C003 **Case Pack 12**
Neilsen 3M Extending Deluxe Wash Brush with Squeegee

- Extendable • Easy to Use • Ergonomic Comfort Grips • Aluminum Handle
- Does not Scratch • Connects to your hose • Cut off tap on the handle
- Rust Proof • Twist Lock Handle • Squeegee with Wiper Blade attachment
- Brush: Soft PVC • Tube: 25mm • Handle Length 1.3 - 3m
- Brush Head: 25cm



Cat No 070500 **Case Pack 2**
Thermoclean 4pack

- Removes stains • Neutralises odours
- Quick and Simple to Use • No Scrubbing
- Does not Bleach • Home or Work
- Comes in strips of 4 • Display box of 30 strips



Cat No 3010M **Case Pack 10**
Universal Carry Bag

- Universal in Use • Easy to Clean • Clear Front
- Soft Polyester Back • Zipped Top • Carry Handle



Cat No 1230 **Case Pack 15**
Small Fold Flat Box with Handles

- Strong • Durable • Lightweight • Folds Flat
- Easy to Clean, Use and Store • Folding Handles
- Capacity: 21L • Size: 39 x 26 x 21 cm.



Cat No 1295 **Case Pack 10**
Fold Flat Box

- Strong • Durable • Easy to Clean • Lightweight • Stackable • Folds Flat
- Easy to Use • Easy to Store • Lightweight • Large Capacity
- Capacity: 32L • Size: : 47.7 x 34.6 x 24 cm



Firemaster **Case Pack 5**

- Fire Extinguisher • Easy to Use • Ideal for Car, Caravan or Home
- Added Safety • Stored Pressure • BC Dry Powder
- Complete with wall mounting.

Cat No 7805: Firemaster FM20 600g
Cat No 7809: Firemaster FM40 950g

Grangers Fabsil
The best protection

Nothing takes the fun out of camping like a leaking tent, but by using the Fabsil range of products you can keep your tent performing at it's best.

Fabsil replicates the original finish applied at manufacture.

By using it you can restore the waterproofing of tents and other equipment, allowing them to perform like new.



Grangers Fabsil

The leading silicone based reproofing solution with mildew inhibitor for woven, natural, and synthetic fabrics. A highly effective silicone-based water repellent treatment for all kinds of tent, tarpaulin, canopies and awning fabrics. Spray application, dries to an odourless and colourless finish.

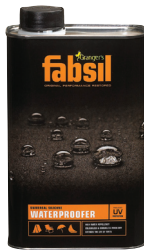

Cat No 7075
Fabsil Liquid 1L

Case Pack 10

- Highly Effective • Industry Leading • Trusted and Used Worldwide • Dries Odourless and Colourless
- UV Treated • Extends the Life of Fabric.
- Volume: 1L
- Coverage: 5 - 18 m².

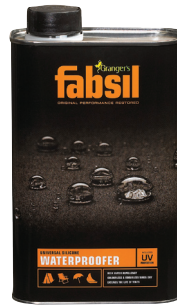

Cat No 7076
Fabsil Liquid 2.5L

Case Pack 10

- Highly Effective • Industry Leading • Trusted and Used Worldwide • Dries Odourless and Colourless
- UV Treated • Extends the Life of Fabric.
- Volume: 2.5L
- Coverage: 12.5 - 45 m².

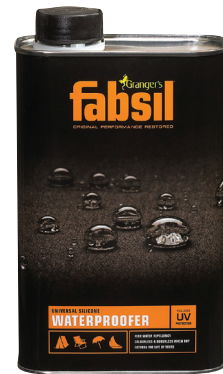

Cat No 7077
Fabsil Liquid 5L

Case Pack 3

- Highly Effective • Industry Leading • Trusted and Used Worldwide • Dries Odourless and Colourless
- UV Treated • Extends the Life of Fabric.
- Volume: 5L
- Coverage: 25 - 90 m².



Cat No 7078
Fabsil Aerosol 400ml

Case Pack 12

- Highly Effective • Industry Leading • Trusted and Used Worldwide • Dries Odourless and Colourless
- UV Treated • Extends the Life of Fabric.
- Volume: 400ml
- Coverage: 2 - 8 m².



Cat No 7079
Fabsil Aerosol 600ml

Case Pack 62

- Highly Effective • Industry Leading • Trusted and Used Worldwide • Dries Odourless and Colourless
- UV Treated • Extends the Life of Fabric.
- Volume: 600ml
- Coverage: 3 - 10 m².



Cat No P0001 **Case Pack** 24
Pro Caravan and Awning Repair Kit

- Best Repair in Class • Easy to Use
- Permanent • Flexible • Waterproof
- Kit Contents: Stormsure adhesive , Tuff Tape Strip , Alcohol Wipe , 8 x 25mm patches , 2 x 75mm patches , 1 x 150 mm clear patch , gloves , glue spreader



Cat No P0002 **Case Pack** 24
Pro Inflatable Tent Tube Repair Kit

- Best Repair in Class • Easy to Use
- Permanent • Flexible • Leak Proof
- Kit Contents: Stormsure adhesive , Tuff Tape Strip , Alcohol Wipe , 8 x 25mm patches , 2 x 75mm patches , 1 x 150 mm clear patch , gloves , glue spreader.



Cat No P0003 **Case Pack** 24
Pro Zip Repair Kit

- Best Repair in Class • Easy to Use
- Permanent
- Kit Contents: TBA



Cat No 077236 **Case Pack** 24
Awning and Tent Repair Kit

- Best Repair in Class • Easy to Use
- Permanent • Flexible • Waterproof
- Kit Contents: One 5grms Tube Flexible Repair Adhesive, Two Self Adhesive Tuff Patches (7.5cm round) ,One Self Adhesive Tuff Strip. (15 x 3 cm).



Cat No 077240 **Case Pack** 24
Self Adhesive Tuff Strips

- Best Repair in Class • Easy to Use
- Permanent • Flexible • Waterproof
- Kit Contents: Two Self Adhesive Tuff Strips. (15 x 3 cm).



Cat No 077234 **Case Pack** 24
Self Adhesive Tuff Patches

- Best Repair in Class • Easy to Use
- Permanent • Flexible • Waterproof
- Kit Contents: Two Self Adhesive Tuff Patches (7.5cm round)



Cat No 7234 **Case Pack** 24
Patchless Repair

- Best Repair in Class • Easy to Use • Permanent
- Flexible • Waterproof.
- One 15grms Tube Flexible Repair Adhesive



Cat No 7080 **Case Pack** 12
Awning Rail Zip Lubricant & General Maintenance Spray

- Awning Rail Lubricant • General lubricant
- Release or anti-stick spray • Instant Gloss Spray
- Colourless • Odourless • Non-staining
- Non-tainting



Cat No 077234 **Case Pack** 24
2 x 5grm Flexible Adhesive

- Best Repair in Class • Easy to Use • Permanent
- Flexible • Waterproof.
- Two 5grms Tube Flexible Repair Adhesive



Cat No 040000 **Case Pack** 4
19" Double Action Hand Pump

- Inflates and Deflates • 3 Valve Adapters
- Continuous Air Stream • Durable • Lightweight
- Accordion Style Non-kink Hose
- Body: Polypropelene • Hose: 80 cm
- Size: 10 x 10 x 47 cm • Volume: 2 x 2.0L



Cat No 040001 **Case Pack** 12
14" Double Action Hand Pump

- Inflates and Deflates • 3 Valve Adapters
- Continuous Air Stream • Durable • Lightweight
- Accordion Style Non-kink Hose
- Body: Polypropelene • Hose: 80 cm
- Size: 9.5 x 9.5 x 36 cm • Volume: 2 x 0.9L



Cat No 040003 **Case Pack** 12
230V AC Electric Pump

- Lightweight • Durable • 230V Mains
- 3 Valve Adapters • Mains Adapter Included
- Body: ABS • Voltage: 230V. (AC) • Power: 130W
- Output: 350 L/M • Pressure: 350mm.



Cat No 040004 **Case Pack** 12
12V DC Electric Pump

- Lightweight • Durable • 12V DC
- 3 Valve Adapters • 12V DC Adapter Included
- Body: ABS • Voltage: 12V. (DC) • Power: 36W
- Output: 350 L/M • Pressure: 350mm.



Cat No 7239 **Case Pack** 5
Reich 14 Litre Easy Pump

- High quality Reich submersible easy pump.
- 14 Litres per minute • Pressure: 0.5 bar
- Pump Diameter: 43mm • Pipe Fitment: 10-12mm
- Voltage: 12V • Current Consumption 10-20w
- Weight: 155g.



Cat No 7247 **Case Pack** 10
Reich 15 Litre Submersible Pump

- With Strainer & cable • Pump Capacity: 15 L/pm
- Suitable replacement for a Carver pump
- Pressure: 1 bar • Pump Diameter: 40mm
- Pipe Fitment: 10-12mm • Voltage: 12V
- Wattage 10-20w • Cable Length 77 -78cm
- Weight 0.175kg.



Cat No 7216W **Case Pack** 6
Replacement mk2 Housing inc filter

- Direct replacement for Carver/Truma Crystal MK2 Housing.
- Saves money • Easy to Use • Direct replacement
- Colour: White

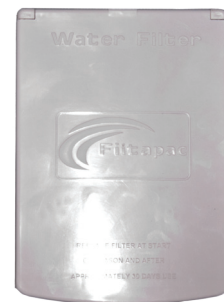

Cat No 7217W **Case Pack** 6
Replacement mk2 Cover in White

- Direct replacement for Carver/Truma Crystal MK2 Cover
- Saves money • Easy to Use • Direct replacement
- Colour: White



Cat No 7260
TWIST Single Lever Mixer Tap (LH Nickel)

Case Pack 10

- High Quality • Durable • Easy to clean • Galvanised Surfaces • Even Flow
- Microswitch • Spout can be raised or lowered vertically
- Left Handed • Nickel Finish • Weight: 0.250kg • Cable length: 600mm
- Maximum pressure 6bar • 39mm installation hole fitmen



Cat No 7260C
TWIST Single Lever Mixer Tap (LH Chrome)

Case Pack 10

- High Quality • Durable • Easy to clean • Galvanised Surfaces • Even Flow
- Microswitch • Spout can be raised or lowered vertically
- Left Handed • Chrome Finish • Weight: 0.250kg • Cable length: 600mm
- Maximum pressure 6bar • 39mm installation hole fitment



Cat No 7268
TWIST Single Lever Mixer Tap (RH Nickel)

Case Pack 10

- High Quality • Durable • Easy to clean • Galvanised Surfaces • Even Flow
- Microswitch • Spout can be raised or lowered vertically
- Right Handed • Nickel Finish • Weight: 0.2kg
- Maximum pressure 6bar



Cat No 7268C
TWIST Single Lever Mixer Tap (RH Chrome)

Case Pack 10

- High Quality • Durable • Easy to clean • Galvanised Surfaces • Even Flow
- Microswitch • Spout can be raised or lowered vertically
- Right Handed • Chrome Finish • Weight: 0.2kg
- Maximum pressure 6bar



Cat No 7274
KAMA Single Lever Mixer Tap with JULIA Hand Shower

Case Pack 10

- High Quality • Durable • Easy to clean • Galvanised Surfaces • Even Flow
- Microswitch • Easy to maintain • Can be used as a normal or shower tap
- Chrome Finish • Cable length 600mm • Maximum pressure: 6 bar
- Drill hole: 36mm



Cat No 7276
TWIST UT Keramik Single Lever Mixer Tap (Chrome)

Case Pack 10

- High Quality • Durable • Easy to clean • Galvanised Surfaces • Even Flow
- Microswitch • Easy to maintain • Flex Hose Connection
- Chrome Finish • Maximum pressure: 6 bar • Drill hole: 39mm
- Suitable for 12mm push fit water connections or 1/2" flexible piping.



Cat No 7270
Single Lever Mixer Keramik Kama R1

- High Quality • Durable • Easy to clean • Galvanised Surfaces • Even Flow
- Microswitch • Easy to maintain • Push fit Connections
- Chrome • Max pressure 6 bar • Drill Hole 33mm

Case Pack 10



Cat No 7275
TREND E Keramik Single Lever Mixer Tap (chrome)

- High Quality • Durable • Easy to clean • Galvanised Surfaces • Even Flow
- Microswitch • Easy to maintain • Flex Hose Connection • Drill Hole 27mm
- Chrome • Flex Hose: 12 mm. • Cable length 600mm • Max pressure 6 bar
- Suitable for 12mm push fit water connections or 1/2" flexible piping.

Case Pack 10



Cat No 7266
Single Lever Mixer Twist Shower

- High Quality • Durable • Easy to clean • Galvanised Surfaces
- Even Flow • Microswitch • Easy to Maintain • Chrome Finish
- 2 Inch Male thread to connect Shower hose

Case Pack 10



Cat No 7267
Single Lever Mixer KAMA (360)

- High Quality • Durable • Easy to clean • Galvanised Surfaces
- 360° Swivelling Spout • Even Flow • Microswitch • Easy to Maintain
- Flex Hose Connection • Max pressure 6 bar • Drill Hole 27 mm

Case Pack 10



Cat No 7248
Reich Single Tap Chrome

- High Quality • Durable • Easy to clean
- Galvanised Surfaces • Even Flow
- Micro switch • Easy to maintain
- Cable length 300mm • Maximum pressure 3 bar
- Installation hole 20mm

Case Pack 10



Cat No 7249
Reich Mixer Tap Chrome

- High Quality • Durable • Easy to clean
- Galvanised Surfaces • Even Flow
- Micro switch • Easy to maintain
- Cable length 300mm • Maximum pressure 3 bar
- Installation hole 20mm

Case Pack 10



Cat No 7269
Single Lever Mixer Twist Spout Chrome

Spare spouts for Keramik, Twist, Kama and Mono taps.

Case Pack 10



Cat No 7202 Case Pack 3
Filta Crystal Cartridges

- Recharges Crystal Filter (Mk1 & 2)
- Same Efficiency & Quality as Original
- Environmentally Friendly • Easy to Use
- Saves Money • Stops Carbon Escaping
- Comes in a display box of 18



Cat No 7203 Case Pack 1
Filta Crystal Cartridges

- Easy to Use • Highest Quality Carbon
- Ensures the quality of your drinking water
- No adaption required • Environmentally friendly
- Eliminates carbon escape into water
- Screws in Place • Replaces Carver/Truma
- Comes in a display box of 20



Cat No 7204 Case Pack 10
Filta Removal Tool

- Easy to Use • Makes Removal of Filter Easy
- Stops unwanted breakages



Cat No 7211 Case Pack 12
Puriclean 100g

- Easy to use • Purifies water system
- Essential safeguard to health • Packed in 12's
- Volume: 100g • Purification Capacity: 15 gallons.



Cat No 7212 Case Pack 6
Puriclean 400g

- Easy to use • Purifies water system
- Essential safeguard to health
- Packed in 6's • Volume: 100g
- Purification Capacity: 60 gallons.



Cat No 7219 Case Pack 6
Aquasol Water Treatment

- Complete Water Treatment • Easy to use
- Kills Bacteria and Viruses • Non-Corrosive
- Keeps Water Pure • Eliminates Bad Tastes
- Does not Harm Water System
- Size: 250ml • Treats 625L of Water



Cat No 07220 Case Pack 6
Wasteguard Waste Water Treatment

- Waste Water Treatment
- Simple and Easy to Use • Destroys Odours
- Prevents Contamination
- Keeps Sinks and Drains Fresh from Odours
- Size: 300 ml.



Cat No 7213 Case Pack 12
Aqua Tabs

- Simple to Use • Purifies water • Foil Wrapped
- Rapid Dissolving • Remain Stable for 5+ Years
- Organic Chlorine Donor • Superior Disinfection
- Display box of 12 • 32 Tabs per box



Cat No 07213 Case Pack 12
Mini Aqua Tabs

- Simple to Use • Purifies water • Foil Wrapped
- Rapid Dissolving • Remain Stable for 5+ Years
- Organic Chlorine Donor • Superior Disinfection
- Display box of 18 • 40 Tabs per box

Kontrol Moisture Products

Keeps unwanted moisture and condensation under control. Protection against damp musty odours and mildew.

Designed to fit window sills and narrow surfaces. Simple to use, sturdy, neat and clean. Battery free - works day and night.



Cat No 8061
Streamline Moisture Trap

Case Pack 12

- Lockable Lid • Easy pour spout • Small Footprint
- Combats Damp • Helps Stop Condensation
- Mildew and Musty Odours • Removes Moisture
- Battery Free • Works Day and Night
- Size: 26.5cm x 9.4cm x 10cm

Cat No 098069
Mega Moisture Trap

Case Pack 6

- Combats Damp • Helps Stop Condensation
- Mildew and Musty Odours • Removes Moisture
- Battery Free • Works Day and Night
- Lockable lid • Uses the Easy to Use Refill Tabz
- Can be refilled with Krystals or tabs



Moisture Muncher

Case Pack 12

- Simple and Easy to Use • Reusable
- Combats Damp • Helps Stop Condensation
- Mildew and Musty Odours • Removes Moisture
- Fits almost Anywhere • Battery Free
- Works Day and Night

Cat No 8066: 200g
Cat No 8067: 500g



Mini Moisture Trap

Case Pack 12

- Combats Damp • Helps Stop Condensation
- Mildew and Musty Odours • Removes Moisture
- Fits almost Anywhere • Battery Free
- Works Day and Night • Lasts Approx 6-8 Weeks

Cat No 8040 Ocean Spray
Cat No 8041 Lavender

Multi-buy deals

- Kontrol Stand Deal • Mini Moisture Pallet Deal
- Kontrol Pallet Deal

Cat No 8065: Kontrol Stand

Cat No 8040PD: Mini Moisture Pallet Deal

Cat No 806261PD: Kontrol Pallet Deal



Cat No 098070
Kontrol Refill Tabz (2pack)

Case Pack 6

- Refil for Mega Moisture Trap



Kontrol Krystals

Case Pack 10

- Refill for any of the Kontrol moisture traps

Cat No 8062: 500g
Cat No 8063: 2500g



Cat No 8039
Drip Strip 3 metre

Case Pack 12

- Stops condensation puddles and stains
- Easy to Use • Simply Stick in Place
- Cut to Size
- Total Length: 3M

The Outdoors

Making the outdoors more enjoyable

Quality products to enhance the enjoyment of the outdoors. Including barbecues, windbreaks, trolleys and more.

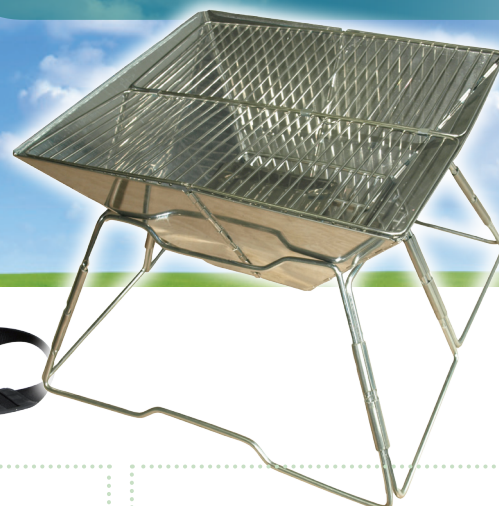

Cat No 7501S **Case Pack** 4
Coolbox and Garden Fridge Stand

- Folds Away in Seconds • Easy to Use
- 2 Different Sizes in One • Stepless Levelling Leg
- Lightweight • Non Slip Padding
- Pos1: • Size: 40 x 50 x 42cm • Height: 42 cm
- Pos2 : • Size: 47 x 50 x 32 cm • Height: 32 cm
- Folded: 58 x 11 x 8 cm • Weight: 1.38 kg

Cat No 7314 **Case Pack** 4
Lighting Blocks

- 14 fuel express fire lighters.

Case Pack 24 **Cat No** 097300 **Case Pack** 12
Quest Folding BBQ

- Easy to Use • Easy to Store • Lightweight
- Portable • Extremely Easy To Assemble
- Zero Tool Assembly • Charcoal or Wood
- Size: 35.5 x 35.5 x 21.5 cm
- Folded: 36 x 23 x 5.2 cm • Weight: 1.9kg.



Cat No O0001 **Case Pack** 4
Portable Table Top BBQ

- Portable • Lightweight • High Quality • Stainless Steel Burner • Easy to Use
- Easy to Store • Folds Away • Vented Lid
- Burner: Stainless Steel • Body: Metal • Legs: Stainless Steel
- Cooking area 44.5 x 31cm



Cat No 133012 **Case Pack** 6
Handy Cooler Seat

- Both a foldaway seat and drinks cooler in one • Folds Away in Seconds
- Easy to Carry • Lightweight • Padded Seat • Fully Insulated Inner
- Capacity: 13.5L • Weight: 1.1 kg
- Holds: 14 bottles (500ml) or 26 cans (330ml)
- Size: 30 x 30 x 29 cm • Folded: 30 x 30 x 10 cm
- Max Load (seat): 100 kg • Max Load (carry): 10



Cat No 092001
Quest Can Caddy (45) Display Box

- Lightweight • Steel Shaft • Screw Fit for Cup Holder • Easy to Store
- Shaft: Steel • Cup Holder: Solid Plastic • Cup Holder Size: 8cm Diameter
- Cup Holder Height: 55 cm • Weight: 0.05 kg.



Case Pack 90 (2 Boxes)



Cat No 092000
Quest Stick Table (20) Display box

- Lightweight • Steel Shaft • Non Slip Cover • Easy to Store • Shaft: Steel
- Table Top: Solid Plastic
- Table Size: 25 x 25 cm • Table Height: 40 cm • Weight: 0.1 kg.

Case Pack 40 (2 Boxes)



Cat No 15101
Large Printed Picnic Rug

- Folds away into its own carry case • PVC Underside
- Supersoft Fabric Upper • Classic Celtic Design
- Size: 135 x 150cm. • Packed: 34 x 20 x 8cm.
- Weight: 0.5kg.

Case Pack 12



Polythene Windbreak

Case Pack 6

- Excellent Value • Multi-coloured • Very Visible • Lightweight • Easy to Carry
- Fabric: Polythene • Poles: Wood.

- Cat No** 1440 **4 Pole (90 x 220 cm)**
- Cat No** 1442 **5 Pole (115 x 270 cm)**
- Cat No** 1445 **6 Pole (115 x 330 cm)**
- Cat No** 1446 **8 Pole (115 x 430 cm)**



Blue Stripe Windbreak

Case Pack 6

- Wooden Poles • Metal End Caps • Metal Spikes • Awning Rail Attachment
- Lightweight
- Non Woven Fabric • Pole Diameter 20mm.

- Cat No** 091452B **5 Pole (123 X 345 cm.)**
- Cat No** 091453B **7 Pole (123 x 520 cm.)**



Green Stripe Windbreak

Case Pack 6

- Wooden Poles • Metal End Caps • Metal Spikes • Awning Rail Attachment
- Lightweight
- Non Woven Fabric • Pole Diameter 20mm.

- Cat No** 091452G **5 Pole (123 X 345 cm.)**
- Cat No** 091453G **7 Pole (123 x 520 cm.)**

Quest Elite® Ragley Range Premium quality and comfort

The Quest Elite Ragley range is a premium range of padded furniture. It uses the exclusive Q600 fabric on all the chairs with extra padding to give maximum comfort. The Q600 fabric is stronger and more durable than traditional fabric, mixed with the additional comfort of extra padding gives an outstanding padded chair.

The range is available in two colours: blue and sage and a variety of chair styles. The entire range have premium quality frames with an outstanding and durable coating giving extra protection against stains, scratches and the elements.

The entire Ragley range is also fully Fire retardant.

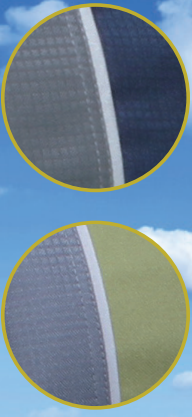

Quest Elite Ragley Range SL Chair with Side Table

Case Pack 4

- Exclusive Slide out Side Table • Premium Quality • Extra Comfort • Extra Durability • Folds Flat • Easy to Store • Padded Extra High Back
- Adjustable Recline • Adjustable Padded Head Rest and Lumbar Support • Fire Retardant • Frame: Powder Coated Steel • Q600 Fabric
- Size: 49 x 39 x 114 cm • Seat Height: 44 cm • Folded Size: 96 x 55 x 11 cm • Weight: 6.2 kg • Max Load: 120 kg • Side Table Max Load: 5 kg.

Cat No 133001 **Blue and Grey**
Cat No 133005 **Sage and Grey**



Quest Elite Ragley Range Extreme Comfort Chair with side Table

Case Pack 4

- Exclusive Slide out Side Table • Premium Quality • Extra Comfort • Extra Durability • Extra Strength • Lightweight • Folds Flat • Easy to Store
- Adjustable Recline • Relaxer Style Elastics • Adjustable Head Rest and Lumbar Support • Extra Wide Seat and Back Rest • Fire Retardant
- Frame: Powder Coated Aluminium • Q600 Fabric • Size: 52 x 42 x 116 cm • Seat Height: 46 cm • Folded Size: 120 x 61 x 11 cm • Weight: 5.68 kg
- Max Load: 120 kg • Side Table Max Load: 5 kg.

Cat No 133002 **Blue and Grey**
Cat No 133006 **Sage and Grey**

QUEST ELITE®

Ragley Range



Cat No: SP132997

Case Pack 6

Quest Elite Ragley Range Eden Chair

- Premium Quality • Extra Comfort • Extra Durability • Extra Strength
- Folds Away • Fully Padded • Premium Quality Padded Carry Bag
- Adjustable Head Rest and Lumbar Support • Load Spreading Front Feet
- Adjustable Front Legs and Recline • Fire Retardant • Powder Coated Steel
- Q600 Fabric • Size: 64 x 70 x 102cm • Seat Height: 40 cm
- Folded: 90 x 65 x 5cm. • Weight: 5kg. • Max Load: 120 kg.



Quest Elite Ragley Range Stepless 'Anti-Gravity' Relaxer

Case Pack 2

- Premium Quality • Extra Comfort • Extra Durability • Extra Strength • The Ultimate Comfort in a Chair • Folds Flat • Easy to Store • Fully Adjustable Recline
- Stepless Adjustment that Locks in Any Position • Folds Away for Easy Storage • Fully Padded • Adjustable Head Rest and Lumbar Support
- Fire Retardant • Frame: Powder Coated Steel • Q600 Fabric • Size: 53 x 54 x 114 cm
- Seat Height: 51 cm • Folded: 15 x 98 x 65 cm • Weight: 9.46 kg • Max Load: 120 kg.

Cat No 133003 **Blue and Grey**

Cat No 133007 **Sage and Grey**



Quest Elite Ragley Range Blue Padded Lounger and Camp Bed

Case Pack 2

- Premium Quality • Extra Comfort • Extra Durability • Extra Strength • Folds Flat • Easy to Store • Fully Padded • Adjustable Back Rest
- Fire Retardant • Frame: Powder Coated Steel • Q600 Fabric
- Size: 76 x 125 - 200 cm • Seat Height: 25 cm • Folded: 77 x 78 x 16 cm • Weight: 8.64 kg • Max Load: 120 kg.

Cat No 133004 **Blue and Grey**

Cat No 133004S **Sage and Grey**

Quest Elite® Sandringham Range Premium Quality and Weather Resistant

The Sandringham range of furniture is a premium quality range of furniture in a classic pattern that is exclusive to Quest Leisure. The range offers durable, all weather fabric matched with a premium quality aluminium frame*. Every piece in the range offers outstanding durability, are portable, lightweight and will last for years.

The entire Sandringham range is fully REACH standard approved, which ensures that the materials contain no harmful chemicals and that none were used during the manufacturing process. The Quest Elite® Sandringham range are also covered by an excellent 2 year guarantee giving you peace of mind and years of use.



Cat No 4978
Sandringham Range Stepless Relaxer

Case Pack 2

- Premium Quality • 2 Year Guarantee • Extremely Comfortable • Includes Drinks Tray • Wooden Arms
- Durable • All Weather Fabric • Lightweight • Portable • Folds Flat • Stepless Recline
- Adjustable Padded Head Rest and Lumbar Support • All Aluminium Frame • REACH Approved
- Frame: Powder Coated Aluminium • Fabric: Qmesh fabric
- Size: 49 x 39 x 114 cm • Seat Height: 44 cm • Folded Size: 95 x 55 x 10 cm
- Weight: 8.18 kg • Max Load: 120 kg.

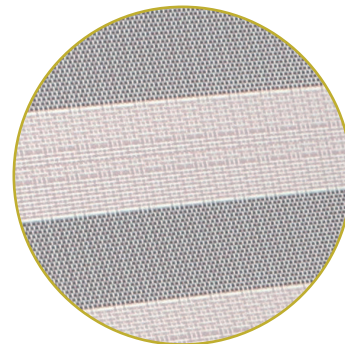

Cat No 4978L
Sandringham Range Lounger with Sun Canopy

Case Pack 4

- Premium Quality • 2 Year Guarantee • Durable • All Weather Fabric • Lightweight • Portable
- Folds Flat • Adjustable Sun Canopy • Adjustable Recline (5 Position) • Can be used Flat
- All Aluminium Frame • REACH Standard Approved
- Frame: Powder Coated Aluminium • Fabric: Qmesh Fabric
- Size: 200 x 59.5 x 30.5 cm • Seat Height: 32 cm
- Folded Size: 62.5 x 16 x 82 cm
- Weight: 6 kg • Max Load: 120 kg.



Quest Elite Universal Padded Cushion

- Premium Quality • Fits XL and SL chairs
- Extra Comfort • Extra Padding
- Adjustable Strap • Easy Clip Buckle
- Size: 125 x 55 cm
- Folded: 50 x 23 x 23 cm
- Weight: 0.78 kg.

Cat No 107000 : Grey
Cat No 107001: Brown

Case Pack 6
Case Pack 6

Quest Elite® Sandringham Range Premium Quality and Weather Resistant

The Sandringham range of furniture is a premium quality range of furniture in a classic pattern that is exclusive to Quest Leisure. The range offers durable, all weather fabric matched with a premium quality aluminium frame*. Every piece in the range offers outstanding durability, are portable, lightweight and will last for years.

The entire Sandringham range is fully REACH standard approved, which ensures that the materials contain no harmful chemicals and that none were used during the manufacturing process. The Quest Elite® Sandringham range are also covered by an excellent 2 year guarantee giving you piece of mind and years of use.

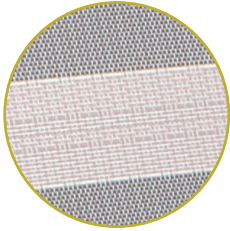

Cat No 4976ST

Sandringham Range XL Chair with Side Table

Case Pack 4

- Exclusive Slide out Side Table • Premium Quality • 2 Year Guarantee
- Durable • All Weather Fabric • Lightweight • Portable
- Extra Wide Seat and Back Rest • Built in Padded Head Rest
- 7 Adjustable Positions • All Aluminium Frame • REACH Standard Approved
- Can be Extended with foot stool
- Frame: Powder Coated Aluminium • Qmesh Fabric
- Size: 52 x 42 x 120 cm • Seat Height: 47 cm
- Folded Size: 99 x 8.6 x 65 cm
- Weight: 5.8 kg • Max Load: 120 kg • Table Max Load: 5 kg.



Cat No 4975ST

Sandringham Range SL Chair with Side Table

Case Pack 4

- Exclusive Slide out Side Table • Premium Quality • 2 Year Guarantee
- Durable • All Weather Fabric • Lightweight • Portable
- Extra High Back Rest • Built in Padded Head Rest • 6 Adjustable Positions
- REACH Standard Approved • Can be Extended with Foot Stool
- Frame: Powder Coated Aluminium and Steel • Qmesh Fabric
- Size: 49 x 39 x 114 cm • Seat Height: 44 cm
- Folded Size: 96 x 55 x 10 cm
- Weight: 5.26 kg • Max Load: 120 kg
- Table Max Load: 5 kg.

Cat No 4976N

Sandringham Range Foot Stool

Case Pack 4

- Foot Stool to Extend the SL and XL Chairs • 2 Year Guarantee
- Can be Used with Virtually Any Other Chair • Premium Quality
- Durable • All Weather Fabric • Lightweight • Portable • Folds Flat
- All Aluminium Frame • REACH Standard Approved
- Frame: Powder Coated Aluminium • Fabric: Qmesh Fabric
- Size: 48 x 48 x 90 cm. • Seat Height: 48 cm.
- Folded Size: 90 x 48 x 9cm.
- Weight: 1.4 kg. • Max Load: 30 kg.

Quest Elite® Riviera Range Premium Quality and Weather Resistant

The Riviera range of furniture is a premium quality range of furniture in a classic pattern that is exclusive to Quest Leisure. The range offers durable, all weather fabric matched with a premium quality aluminium frame*. Every piece in the range offers outstanding durability, are portable, lightweight and will last for years.

The entire Riviera range is fully REACH standard approved, which ensures that the materials contain no harmful chemicals and that none were used during the manufacturing process. The Quest Elite® Riviera range are also covered by an excellent 2 year guarantee giving you piece of mind and years of use.



Cat No 154978

Riviera Range Stepless Relaxer

Case Pack 2

- Premium Quality • 2 Year Guarantee • Extremely Comfortable • Exclusive Slide out Side Table
- Wooden Effect Arms • Durable • All Weather Fabric • Lightweight • Portable • Folds Flat
- Stepless Recline • Adjustable Padded Head Rest and Lumbar Support • All Aluminium Frame • Frame: Powder Coated Aluminium • Fabric: Qmesh fabric
- Size: 49 x 39 x 114 cm • Seat Height: 44 cm • Folded Size: 95 x 55 x 10 cm
- Weight: 8.18 kg • Max Load: 120 kg.



Cat No 154980

Riviera Range Lounger

Case Pack 4

- Premium Quality • 2 Year Guarantee • Durable • All Weather Fabric
- Lightweight • Portable • Folds Flat • Extra High Seat Position
- Adjustable Recline (5 Position) • Can be used Flat
- All Aluminium Frame • REACH Standard Approved
- Frame: Powder Coated Aluminium • Fabric: Qmesh Fabric
- Size: 198 x 68 x 48 cm • Seat Height: 48 cm
- Folded Size: 69 x 22 x 82 cm
- Weight: 5.8 kg • Max Load: 120 kg.



Cat No 154977

Riviera Range Extreme Comfort with Side Table

Case Pack 4

- Exclusive Slide out Side Table • Premium Quality • Lightweight
- Extra Comfort • Extra Durability • Extra Strength
- Folds Flat • Easy to Store • Adjustable Recline • Relaxer Style Elastics
- Adjustable Head Rest and Lumbar Support
- Extra Wide Seat and Back Rest
- Frame: Powder Coated Aluminium • Q600 Fabric
- Size: 52 x 42 x 116cm • Seat Height: 46cm • Folded Size: 120 x 61 x 11cm
- Weight: 5.68 kg • Max Load: 120 kg • Side Table Max Load: 5 kg.

Quest Elite® Riviera Range Premium Quality and Weather Resistant

The Riviera range of furniture is a premium quality range of furniture in a classic pattern that is exclusive to Quest Leisure. The range offers durable, all weather fabric matched with a premium quality aluminium frame*. Every piece in the range offers outstanding durability, are portable, lightweight and will last for years.

The entire Riviera range is fully REACH standard approved, which ensures that the materials contain no harmful chemicals and that none were used during the manufacturing process. The Quest Elite® Riviera range are also covered by an excellent 2 year guarantee giving you piece of mind and years of use.



Cat No 154975
Riviera Range SL Chair with Side Table

Case Pack 4

- Exclusive Slide out Side Table • Premium Quality • 2 Year Guarantee
- Durable • All Weather Fabric • Lightweight • Portable
- Extra High Back Rest • Built in Padded Head Rest • 6 Adjustable Positions
- REACH Standard Approved • Can be Extended with Foot Stool
- Frame: Powder Coated Aluminium and Steel • Qmesh Fabric
- Size: 49 x 39 x 114 cm • Seat Height: 44 cm
- Folded Size: 96 x 55 x 10 cm
- Weight: 5.26 kg • Max Load: 120 kg
- Table Max Load: 5 kg.



Cat No 154976
Riviera Range XL Chair with Side Table

Case Pack 4

- Exclusive Slide out Side Table • Premium Quality • 2 Year Guarantee
- Durable • All Weather Fabric • Lightweight • Portable
- Extra Wide Seat and Back Rest • Built in Padded Head Rest
- 7 Adjustable Positions • All Aluminium Frame • REACH Standard Approved
- Can be Extended with foot stool
- Frame: Powder Coated Aluminium • Qmesh Fabric
- Size: 52 x 42 x 120 cm • Seat Height: 47 cm
- Folded Size: 99 x 8.6 x 65 cm
- Weight: 5.8 kg • Max Load: 120 kg • Table Max Load: 5 kg.



Cat No 154979
Riviera Range Foot Stool

Case Pack 4

- Foot Stool to Extend the SL and XL Chairs
- Can be Used with Virtually Any Other Chair • Premium Quality
- 2 Year Guarantee • Durable • All Weather Fabric • Lightweight
- Portable • Folds Flat • All Aluminium Frame
- REACH Standard Approved
- Frame: Powder Coated Aluminium • Fabric: Qmesh Fabric
- Size: 48 x 48 x 90 cm. • Seat Height: 48 cm.
- Folded Size: 90 x 48 x 9cm.
- Weight: 1.4 kg. • Max Load: 30 kg.



Quest Elite® Deluxe Range
Premium quality, comfort and style.

The deluxe range from Quest are a range of furniture that combine quality parts and manufacturer with style and excellent features to create a unique and exclusive range only available from Quest.

The moon chairs are made the most comfortable moon chairs currently available. They feature extra padding and an exclusive added comfort padded ring. They also feature a unique single action fold out frame which not only makes it very easy to fold out, but allows it to fold down to a smaller pack size.

The deluxe moon chair has won the best for style award in the April 2013 Caravan Buyer magazine. They love the chair, saying that it is a great comfortable chair. It is the nearest thing to an armchair that you can get for the outdoor leisure market and is built with substantial materials.



Deluxe Range Moon Chairs

Case Pack 4

- Premium Quality • Fire Retardant • Lightweight • Portable • Extremely Comfortable • Unique Single Fold Mechanism • Extra Padded Seat
- Exclusive Padded Edge • High Quality Carry Bag • Carry Handles • Frame: 16mm Steel
- Fabric: 600D Polyester

Cat No 104972A: Large Apple

Cat No 10497AS: Medium Apple

Cat No 104972N: Large Navy

Cat No 10497NS: Medium Navy

Cat No 104972P: Large Paprika

- Large Moon Chair: Size: 51 x 51 x 94 cm • Seat Height: 50 cm • Folded Size: 32 x 22 x 102 cm • Weight: 6.9 kg.
- Medium Moon Chair: Size: 42 x 44 x 78 cm • Seat Height: 38 cm • Folded Size: 34.5 x 23 x 15 cm • Weight: 5.6 kg • Max Load: 100 kg



- Exclusive Design • Extreme Comfort • Premium Quality • Lightweight • Compact and Portable • Strong and Lightweight • Integrated Aluminium Arm Rests
- Safety Lock • Folds Away for Easy Storage • Padded Seat and Head Rest • Colour Coded Carry Bag • Frame: 22mm Steel • Fabric: 600d Polyester
- Size: 65 x 46 x 94 cm • Seat Height: 48 cm • Folded Size: 90 x 25 x 19 cm • Weight: 5.6 kg • Max Load: 120 kg.

Cat No 106508P **Comfort Plus Folding Chair in Paprika**
Cat No 106508S **Comfort Plus Folding Chair in Sage**

Case Pack 6
Case Pack 6



- Exclusive Design • Extreme Comfort • Premium Quality • Lightweight • Compact and Portable • Strong and Light Frame • Adjustable Rear Legs and Recline
- Integrated and Adjustable Arm Rests • Safety Lock • Padded for Comfort • Folds Away for Easy Storage • Colour Coded Carry Bag • Frame: 22mm Steel
- Fabric : 600d Polyester • Size: 66 x 55 x 107 cm • Seat Height: 51 cm • Folded Size: 98 x 18 x 16 cm • Weight: 4.5 kg • Max Load: 120 kg.

Cat No 106509P **Comfort Folding Chair in Paprika**
Cat No 106509S **Comfort Folding Chair in Sage**

Case Pack 6
Case Pack 6



Deluxe Directors Chair

Case Pack 10

- Ultra Fine Coated Frame • Fold Out Side Table with Duratech Table Top
- Padded Back Rest • Folds Away for Easy Storage • Locking Side Table
- Reinforced Aluminium Frame • Carry Handles • Size: 55 x 61.5 x 81 cm
- Folded Size: 46 x 80 x 20 cm • Seat Height: 41 cm
- Weight 3.2 kg • Max Load: 150 kg • Side Table Max Load: 100kg.

Cat No 154994
Cat No 154994BG

Blue
Burgundy



Cat No 154992
Deluxe Beach Chair

Case Pack 6

- Ultra Fine Frame Coating • Exclusive Design • Lightweight • Portable
- Excellent Build Quality • Adjustable Back • Folds Away for Easily
- Easy to Store • Frame: Steel • Fabric: 600D Coated Polyester
- Size: 56 x 72 x 93cm • Seat Height: 39cm • Folded Size: 56 x 10 x 77cm
- Weight: 2.6 kg • Max Load: 100 kg



Quest Elite® Comfort Plus Range

Premium quality, comfort and style.

The Quest Elite Comfort Plus range offers premium quality and comfort in a modern striking style. They combine breathable backs to allow your back to breath and thus sweat less with class leading materials and extra strength frames.

The extra dense padding is more comfortable and more durable than its rivals and as soon as you sit in any of the range you immediately feel the extra comfort extra support.



Cat No 152997
Andes Directors Chair

Case Pack 4

- 2 Year Extended Warranty • Extra high 150kg max load • Fold out side table
- Premium Quality • Extra Comfort • Extra Dense Padding • Frame Folds Flat
- Easy to Store • Extra Strong Frame
- Frame: Coated Steel • Fabric: Q2400 Polycotton
- Size: 52 x 41 x 91 cm • Seat Height: 44 cm
- Folded: 92 x 67 x 17 cm • Weight: 8.1 kg
- Max Load: 150kg.

Cat No 152999
Atlas Folding Chair

Case Pack 4

- 2 Year Extended Warranty • Extra high 150kg max load • Adjustable Recline
- Premium Quality • Extra Comfort • Extra Dense Padding • Frame Folds Flat
- Easy to Store • Extra Strong Frame • Carry Bag
- Frame: Coated Steel • Fabric: Q2400 Polycotton
- Size: 53 x 45 x 102 cm • Seat Height: 44 cm
- Folded: 97 x 29 x 17 cm • Weight: 6.4 kg
- Max Load: 150kg.

Quest Traveller

Easy to Use, Store, Pack and Carry

The Quest traveller ranges of furniture are made to high standards with high quality materials.

They are made to be lightweight, portable and easy to use. They have multiple uses and great practicality so they can be used on holiday, in the garden or even simply put in the car for a quick getaway.

They combine the high quality materials, ease of use, great features and multi use practicality into one great package at an affordable price.



Quest Traveller Kent Wrap Around Chair with Carry Bag

Case Pack 6

- High Quality • All Round Padding for Maximum Comfort • Extremely Comfortable • Protects From the Wind • Lightweight • Portable • Arm Support
- Powder Coated Frame • Folds Away Easily • Includes Carry Bag • Frame: Powder Coated Steel • Fabric : 600D Polyester • Size: 43 x 44 x 86 cm
- Folded Size: 80 x 15 x 20 cm • Seat Height: 45 cm • Weight: 3.2 kg • Max Load: 120 kg.

Cat No 106510P **Paprika**

Cat No 106510S **Sage**



Quest Traveller Surrey Directors Chair with Side Table

Case Pack 6

- High Quality Materials - Lightweight • Portable • Breathable Mesh Back Panel • Folds Away Easily • Locking Side Table • Can be Stood Up When Folded
- Fabric: Polyester • Mesh Back Panel: Textilene • Frame: Powder Coated Alloy • Table Top: MPF • Size: 85 x 58 x 50 cm • Folded Size: 85 x 50 x 14 cm
- Seat Height: 49 cm • Weight: 3.1 kg • Max Load: 100 kg

Cat No 106504P **Paprika**

Cat No 106504S **Sage**



Quest Traveller Devon Folding Stool or Foot Rest with Carry Bag

Case Pack 6

- Can Be Used as a Foot Rest as well as a Stool • High Quality Materials • Lightweight • Portable • Strong Frame Design • Reinforced Corners
- Powder Coated Frame • Includes Carry Bag • Material: Polyester • Frame: Powder Coated Steel • Size: 30 x 37 x 59 cm • Folded Size: 56 x 10 x 10 cm
- Seat Height: 36 cm • Weight: 0.9 kg • Max Load: 100 kg.

Cat No 106502P **Paprika**

Cat No 106502S **Sage**



Quest Traveller Dorset Chair

Case Pack 6

- High Quality • Easy to Fold • Easy to Store • High Back
- Adjustable Recline • Extremely Lightweight
- Coated Steel Frame • Size: 60 x 61 x 98 cm • Seat Height: 43 cm
- Folded: 59 x 89 x 9.5 cm • Weight: 3.9 kg • Max Load 100 kg.

Cat No 155306 **Blue**

Cat No 155307 **Red**



Quest Traveller Kendal Compact Chair

Case Pack 6

- High Quality • Easy to Fold • Easy to Store • Extra Strength Piping • Cup Holder • Adjustable Arms • Includes Carry Case
- Coated Steel Frame • Size: 55 x 89 x 85 cm • Seat Height: 44 cm • Folded: 90 x 15 x 15 cm • Weight: 2.8 kg • Max Load 100 kg.

Cat No 155302 **Blue**

Cat No 155303 **Red**



Cat No 4907N

Quest Traveller Chepstow Blue Comfort Chair

Case Pack 6

- All Weather Textilene Fabric • Aluminium Frame • Extremely Lightweight
- Very Portable • Folds Away Easily • Single Fold Action
- Easy to Store Away • Size : 50 x 55 x 87 cm • Seat Height: 42 cm
- Folded Size: 55 x 62 x 7 cm • Weight: 2.1 kg • Max Load: 100 kg



Cat No F156002

Warwickshire 2 Person Bistro Set

Case Pack 4

- Medium Circular table • Toughened Safety Glass • Tinted Glass Table Top
- Adjustable Recline Chairs • Chairs Fold Flat for Easy Storage
- Weatherproof Fabric • Powder Coated Steel Frame • Textilene Fabric
- Table** • Size: 66cm • Height: 70cm • Weight: 6.3kg • Max Load: 50kg
- Chairs** • Size: 83 x 54 x 90cm • Seat Height: 44cm • Folded: 10 x 80 x 52cm
- Weight: 4kg • Max Load: 114kg

Traveller Ibiza Range Lightweight, Easy to Use

The Traveller Light range is an easy to use lightweight range of furniture. Ideal for those who want a quality piece of furniture that is easy to use and easy to carry and move around.

All the items feature weatherproof textilene which dries extremely quickly and is naturally lightweight and durable.



Cat No F156009

Quest Traveller Ibiza Range Anti-Gravity Relaxer

- High Quality • Folds Flat • Easy to Store • Fully Adjustable Recline
- Stepless Adjustment • Folds Away for Easy Storage • Fully weatherproof textilene • Adjustable Head Rest and Lumbar Support
- Frame: Powder Coated Steel • Textilene Fabric • Size: 53 x 54 x 114 cm
- Seat Height: 51 cm • Folded: 15 x 98 x 65 cm • Weight: 7.5 kg • Max Load: 120 kg.

Case Pack 4



Cat No F156011

Quest Traveller Ibiza Range Club Chair

- High Quality • Durable • All Weather Fabric • Lightweight • Portable
- Adjustable Padded Head Rest • 4 Adjustable Positions • Extremely comfortable hammock style seat
- Frame: Powder Coated Steel • Textilene Fabric
- Size: 60 x 75 x 90 cm • Seat Height: 40 cm
- Folded Size: 128 x 60 x 18 cm
- Weight: 5.7 kg • Max Load: 120 kg

Case Pack 4



Cat No F156005

Quest Traveller Ibiza Range Comfort Chair

- High Quality • Durable • All Weather Fabric • Lightweight • Portable
- High Back Rest • Easy to Store • Adjustable Back Rest
- Frame: Powder Coated Steel • Textilene Fabric
- Size: 85 x 54 x 106 cm • Seat Height: 43 cm
- Folded Size: 80 x 52 x 10 cm
- Weight: 4.3 kg • Max Load: 100 kg

Case Pack 12



Childrens Range

Fun, Lightweight and Safety

The Quest childrens range are products built with children in mind. They are the perfect blend of fun, vibrant designs, safety and practicality.

Lightweight and easy for children to carry. Safety locks and straps for piece of mind. Easy to clean materials all add up to a great childrens chair that is also bright, vibrant and fun to look at..

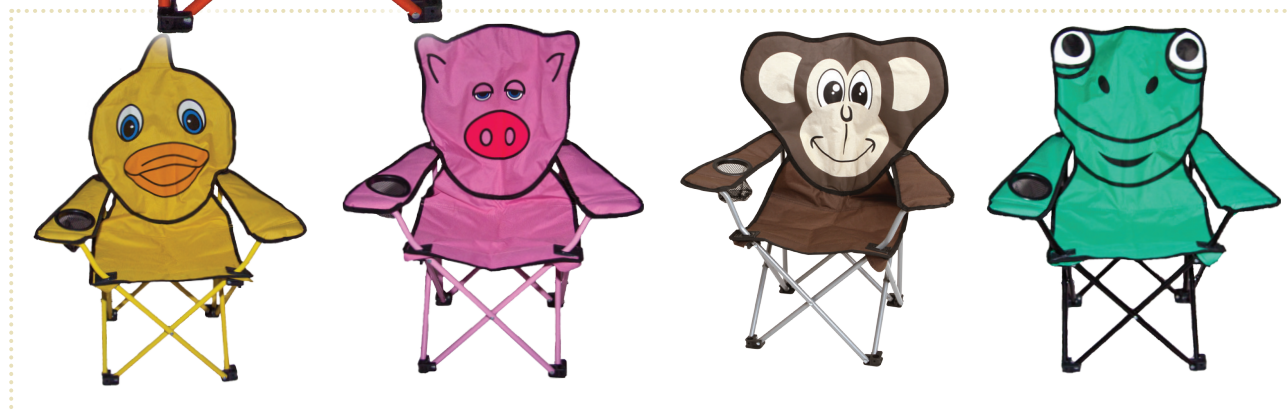

Quest Kids Animal Chairs

Case Pack 12

- Vivid Colour • Animal Design • Integrated Cup Holder • Lightweight • Built in Safety Lock • Folds Away for Easy Storage
- Colour Coded Carry Bag • Frame: Steel • Fabric: 600d PE Coated Polyester
- Size: 57 x 36.5 x 66cm • Seat Height: 28cm • Folded Size: 14 x 14 x 66cm • Weight: 2.2kg • Max Load: 45kg.

Cat No	Description
5203	Tiger
5203D	Duck
5203F	Frog
5203M	Monkey
5203P	Pig



Cat No 105007
Childrens Monkey Garden Set

Case Pack 2

- Adjustable Height Umbrella • Chairs Fold Flat • Easy to Store
- Safety Lock on Chairs • Padded Back on Seats • Steel frame
- Umbrella Diameter: 100 cm • Height: 80 - 117 cm • Weight: 0.48 kg
- Table Diameter: 50 cm • Height: 48 cm • Weight: 1.5 kg.
- Chair Size: 40 x 37 x 50 cm • Weight: 0.8 kg • Max Load: 50 kg
- Seat Height: 26 cm • Folded Size: 40 x 50 x 7 cm.



Cat No 105006
Childrens Monkey Double Swing with Canopy

Case Pack 2

- Fun Childrens Design • Two Padded Backs
- Two Safety Harnesses • Adjustable Canopy
- Wipeable Fabric • Stain Resistant
- Frame: Coated Steel • Size: 115 x 75 x 110 cm.
- Max Load: 100 kg.

Westfield Outdoors® Avantgarde Range

All of the Westfield Outdoors ranges of furniture represent the highest standard of products available today.

The Avantgarde range is their ultimate, top of the line range. It is the ultimate chair for the person who wants everything from their chair.

The range features the world exclusive Duragore 3D fabric which is softer than textile, just as weatherproof, but far more durable. The fabric is also padded, but even the padding dries quickly and does not soak up the water like traditional padding. The frame is made from another world exclusive material, duralight which is a brand new alloy which is stronger and lighter than aluminium giving you the perfect blend and weight and strength. The frame also features a unique folding mechanism and shape which allows it to fold down into a smaller package than any of its rivals.



Avantgarde Range Advantages

- 5 Year Warranty • Solid Metal Joints
- DuraGore 3D: Highly Durable , Breathable and Quick Drying
- Duralight Frame: Lighter and stronger than aluminium
- Soft and Comfortable Padding
- Weather Proof • Fast Drying
- UV-Resistant

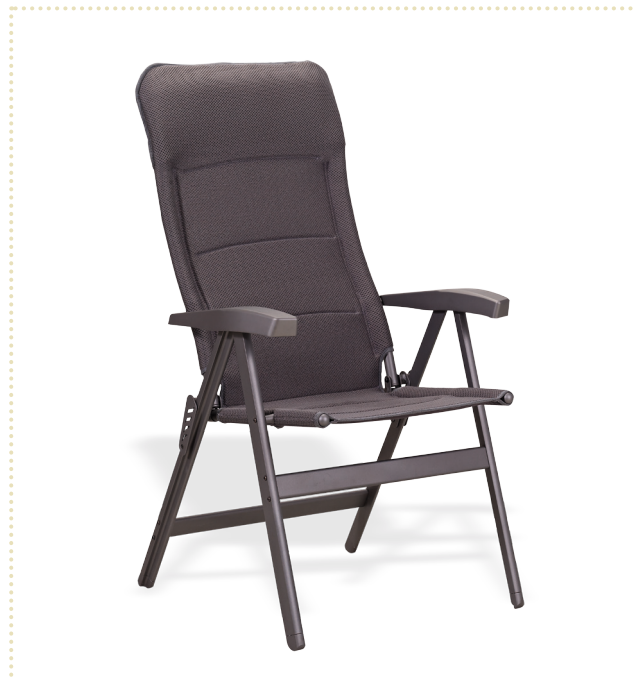

Cat No F0001
Avantgarde AVH 101 Chair

- 5 Year Warranty • Ergonomic Back Rest • Adjustable Recline
- Extremely Comfortable • Lightest Padded Chair in its Class
- Very Flat Folded Size • Fully Sewn Seams • Double Stitching
- High Max Load • Can be Extended with Leg Extension
- Frame: Duralight • Fabric: DuraGore 3D

- Size: 64 x 88 x 120 cm • Seat Height: 47 cm • Folded: 114 x 64 x 10 cm
- Weight: 5.2 kg • Max Load: 140 kg.



Case Pack 6 **Cat No** F0002
Avantgarde AVF 101 Leg Extension

- 5 Year Warranty • Clicks on in Seconds • Fully Padded
- Extremely Comfortable • Lightest Padded Leg Extension in its Class
- Very Flat Folded Size • Fully Sewn Seams • Double Stitching
- Frame: Duralight • Fabric: DuraGore 3D

- Size: 80 x 50 x 36 cm • Height: 40 cm • Folded: 89 x 50 x 10 cm
- Weight: 1.4 kg • Max Load: 30 kg.

Westfield Outdoors® Be Smart Range

All of the Westfield Outdoors ranges of furniture represent the highest standard of products available today.

The Be Smart range is their modern and technical range that features gives the user smaller folded sizes and lighter weights. The perfect solution when weight or size is extremely important.

The range features the exclusive Duragore fabric which is softer and more comfortable than textile and far more durable than standard materials. The supersoft nature of the fabric gives you the maximum of comfort and it is also breathable which keeps you cooler when the weather is warmer. The entire range is covered by a market leading 5 year warranty.



Be-Smart Range Advantages

- 5 Year Warranty • NyloGore Joints
- DuraGore Breathable and Supersoft Fabric
 - All Aluminium Frame
- Super Soft and Comfortable
- UV-Resistant • Rot Proof



Be Smart SRH 301 Chair

Case Pack 6

- 5 Year Warranty • Ergonomic Back Rest • Adjustable Recline
 - Extremely Comfortable • Lightest Chair in its Class
 - Very Flat Folded Size • Fully Sewn Seams • Double Stitching
 - Breathable so stays comfortable for longer periods and helps stop sweating
 - Can be Extended with Leg Extension
 - Frame: Aluminium • Fabric: DuraGore
- Size: 64 x 88 x 120 cm • Seat Height: 47 cm • Folded: 114 x 64 x 10 cm
• Weight: 5.2 kg • Max Load: 140 kg.

Cat No F0003:
Cat No F0004:

Grey
Blue



Be Smart SCO 202 Leg Extension

Case Pack 6

- 5 Year Warranty • Clicks on in Seconds • Fully Padded
 - Extremely Comfortable • Lightest Leg Extension in its Class
 - Very Flat Folded Size • Fully Sewn Seams • Double Stitching
 - Breathable so stays comfortable for longer periods and helps stop sweating
 - Frame: Aluminium • Fabric: DuraGore
- Size: 50 x 40 x 85 cm • Height: 40 cm • Folded: 89 x 50 x 10 cm
• Weight: 1.4 kg • Max Load: 30 kg.

Cat No F0005:
Cat No F0006:

Grey
Blue

Westfield Outdoors® Performance Range

All of the Westfield Outdoors ranges of furniture represent the highest standard of products available today.

The Performance range is their extreme weather and durability range. It is the perfect solution for anyone wanting the best in strength and durability. They are truly products for a lifetime.

The range features the exclusive Duramesh textilene fabric, which is denser, stronger and more durable than all its rivals and features an exclusive weave pattern making the product look nicer and perform better. The frames are reinforced aluminium making them strong but exceeding strong. The range also features the supreme chair which has extra width and the highest maximum load available.



Performance Range Advantages

- 5 Year Warranty • Solid Metal Joints
- DuraMesh Weatherproof Fabric
- Reinforced Extra Strength Aluminium Frame
- Extremely Durable • Weather Proof
- UV-Resistant



Performance PRI 201 Prime Chair

Case Pack 6

- 5 Year Warranty • Ergonomic Back Rest • Adjustable Recline
- Padded Head Rest • Padded Lumbar Support • Fully Sewn Seams
- Double Stitching • High Max Load • Built to last
- Can be Extended with Leg Extension
- Frame: Reinforced Aluminium • Fabric: DuraMesh
- Size: 69 x 64 x 120 cm • Seat Height: 47 cm • Folded: 98 x 62 x 16 cm
- Weight: 5.8 kg • Max Load: 140 kg.

Cat No F0007:
Cat No F0008:

Charcoal
Blue



Performance PSU 201 Supreme Chair

Case Pack 6

- 5 Year Warranty • Ergonomic Back Rest • Adjustable Recline
- Extra Wide Seat • Padded Head Rest • Padded Lumbar Support
- Fully Sewn Seams • Double Stitching • Highest Max Load Available
- Can be Extended with Leg Extension
- Frame: Reinforced Aluminium • Fabric: DuraMesh
- Size: 74 x 70 x 125cm • Seat Height: 47cm • Folded Size: 102 x 72 x 16cm
- Weight: 6.6 kg • Max Load Weight: 200 kg

Cat No F0009:
Cat No F0010:

Charcoal
Blue

Westfield Outdoors® Extra Options

All of the Westfield Outdoors ranges of furniture represent the highest standard of products available today.

The leg extensions allow you to extend your chair to a full lounge giving you maximum flexibility and use. The stability feet add stability and help stop legs sinking into wet ground.

The entire range is covered by a market leading 5 year warranty.



Performance PCO 201 Leg Extension

Case Pack 6

- 5 Year Warranty • Solid Metal Joints • DuraMesh Fabric • Weatherproof
- Clicks on in seconds • Fits PSU201 and PRI201 Chairs • Fully Sewn Seams
- Oeko-Tex 100 Certification • UV-Resistant • Extremely Durable • Lightweight
- Frame: Reinforced Aluminium • Fabric: DuraMesh
- Size: 50 x 44 x 97 cm • Height: 44 cm • Folded: 9 x 50 x 87 cm
- Weight: 1.2 kg.

Cat No F0011: **Charcoal**

Cat No F0012: **Blue**



Be Smart SCO 202 Leg Extension

Case Pack 6

- 5 Year Warranty • Clicks on in Seconds • Very Flat Folded Size
- Extremely Comfortable • Lightest Leg Extension in its Class
- Fully Sewn Seams • Double Stitching
- Breathable so stays comfortable for longer periods and helps stop sweating
- Frame: Aluminium • Fabric: DuraGore
- Size: 50 x 40 x 85 cm • Height: 40 cm • Folded: 89 x 50 x 10 cm
- Weight: 1.4 kg • Max Load: 30 kg.

Cat No F0005: **Grey**

Cat No F0006: **Blue**



Cat No F0002

Avantgarde AVF 101 Leg Extension

Case Pack 6

- 5 Year Warranty • Clicks on in Seconds • Fully Padded
- Extremely Comfortable • Lightest Padded Leg Extension in its Class
- Very Flat Folded Size • Fully Sewn Seams • Double Stitching
- Frame: Duralight • Fabric: DuraGore 3D
- Size: 80 x 50 x 36 cm • Height: 40 cm • Folded: 89 x 50 x 10 cm
- Weight: 1.4 kg • Max Load: 30 kg.



Cat No W12200

Load Spreading Stability Feet

Case Pack 6

- Spreads the load from the chair • Helps stop the leg sinking into the ground
- Premium Quality • Increases Stability
- Fits Supreme and Prime Westfield Chair • Can Fit Other Chairs

Quest Elite® Duratech Tables

More durability built in

These are the new duratech range of tables from Quest. They feature a brand new and exclusive tabletop and frame coating. This new table top is more durable than previous tables tops and offers better scratch resistance, water resistance and heat resistance than previous generations. The new frame coating is an excellent premium coating which looks much better than its rivals and the new table top adds that look and feel of a premium product.

All the duratech range of tables feature the exclusive duratech table top as well as lightweight aluminium frames, adjustable heights and independently adjustable levelling legs.

The duratech range are a lightweight, very stable and adjustable range of premium tables that cannot be matched anywhere else.



Cat No 154843

Quest Elite Duratech Evesham Table

Case Pack 12

- Premium Quality • Lightweight • Easily Portable • Adjustable Height
- Adjustable Feet • Premium Black Wood Effect Top
- Folds Away into very small size • Integrated Carry Handle
- Ultra Fine Coated Frame • Unique Melamine Coated Duratech Top
- More Scratch, Heat and Westher Resistant than rival table tops
- Frame: UFC Aluminium • Table Size: 34 x 56 cm
- Heights: 23 and 45 cm • Folded: 34 x 56 x 4 cm • Weight: 1.8 kg.



Cat No 154849

Quest Elite Duratech Cleeve Folding Table

Case Pack 6

- Premium Quality • Lightweight • Easily Portable • Adjustable Height
- Adjustable Feet • Premium Black Wood Effect Top
- Folds Away into very small size • Integrated Carry Handle
- Ultra Fine Coated Frame • Unique Melamine Coated Duratech Top
- More Scratch, Heat and Westher Resistant than rival table tops
- Frame: UFC Aluminium • Table Size: 80 x 40 cm
- Heights: 31, 44, 55 and 68 cm • Folded: 40 x 40 x 8 cm • Weight: 3.2 kg.

Shots of folded away table (all items)

- The table folds away into its own carry case. (The evesham table does not fold away, but it is already its own carry case).
- The legs are stowed away under the table



Cat No 154845

Quest Elite Duratech Brean Folding Table

Case Pack 6

- Premium Quality • Lightweight • Easily Portable • Adjustable Height
- Adjustable Feet • Premium Black Wood Effect Top
- Folds Away into very small size • Integrated Carry Handle
- Ultra Fine Coated Frame • Unique Melamine Coated Duratech Top
- More Scratch, Heat and Westher Resistant than rival table tops
- Frame: Aluminium • Table Size: 90 x 60 cm
- Heights: 68 and 36 cm • Folded: 45 x 60 x 8 cm • Weight: 4.1 kg.



Cat No 2719KC **Case Pack 6**
Quest Elite® Gloucester Deluxe Folding Set

- Lightweight, Extremely Easy to Use • Premium Quality • Onyx Effect Top
- Shower Proof • Integrated Carry Case.
- Frame: Aluminium • Size: 97 x 82 x 73 cm • Folded: 36 x 86 x 10 cm
- Table Size: 72 x 86 cm • Weight: 12kg.



Cat No 125854 **Case Pack 4**
Quest Elite® Superlite A-Frame Deluxe Table

- Premium Quality • Large Family Size Table • Easy Fold Legs
- Extremely Stable • A Frame Style Legs • Lightweight • Portable
- Folds Away Easily • Onyx Effect Shower Proof Table Top • Easy to Store
- Frame: 25cm Square Alloy • Table Size: 110 x 60 cm • Height: 70 cm
- Folded Size: 110 x 60 x 8cm • Weight: 4.54 kg.



Cat No 155099 **Case Pack 12**
Pair of Packaway Aluminium Folding Stools

- Packs Away Very Small • Extremely Lightweight • Extremely Portable
- All Aluminium Frame • Weatherproof
- Frame: Aluminium • Size: 27.5 x 24 x 42 cm. • Seat Height: 42cm.
- Folded: 27.5 x 48 x 5 cm. • Weight: 0.8 kg • Max Load: 100 kg.



Cat No 125900 **Case Pack 6**
Quest Elite® Packaway Deluxe Slatted Table

- Premium Quality • Packs Away Very Small • Lightweight • Portable
- All Aluminium Frame • Stepless Adjustment on Legs
- Complete with Carry Bag
- Table Size: 90 x 53cm • Height: 45 - 75 cm • Folded: 90 x 20 x 10 cm
- Weight: 3.9 kg • Max Load: kg.



Cat No 124525 **Case Pack 5**
Superlite Onyx Junior Table

- Premium Quality • Lightweight • Compact
- Portable • Folds Away • Onyx Effect
- Shower Proof Top • Integrated carry handle.
- Table Size: 40 x 40 cm • Height: 29.5 cm.
- Folded: 40 x 40 x 2 cm. • Weight: 0.98 kg.



Cat No 124527 **Case Pack 4**
Superlite Onyx Senior Table

- Replacement Elastics for the Quest Elite relaxers
- Strong • Premium Quality
- Quantity: 4 Cords (2 of each size)
- Size: 72 inches and 36 Inches.



Cat No 124852 **Case Pack 5**
Superlite Onyx Medium Table

- Car and Caravan Die Cast Childrens Toy
- Car and Caravan can be Separated
- Opening Doors on Car
- Comes in a display box of 12 with 3 different combinations



Cat No 155103
Superlite Shipston Table

Case Pack 6

- Lightweight • Portable • Locking Legs • Carry Handle
- Shower Proof Top • Folds Away Easily • Weave Effect Top
- Frame: Aluminium • Table Top: Shower Proof Covered MDF
- Table Size: 72 x 49 cm • Table Height: 62 cm
- Folded Size: 72 x 49 x 4.5 cm • Weight: 2.4 kg.



Cat No 155104
Superlite Burford Table

Case Pack 6

- Lightweight • Portable • Locking Legs • Carry Handle
- Shower Proof Top • Folds Away Easily • Weave Effect Top
- Frame: Aluminium • Table Top: Shower Proof Covered MDF
- Table Size: 80 x 60 cm • Table Height: 68 cm
- Folded Size: 80 x 60 x 4.5 cm • Weight: 3 kg.



Cat No 155105
Superlite Witney Table

Case Pack 6

- Extremely Lightweight • Extremely Compact • Portable • Locking Legs
- Folds away for easy storage • Weave Effect Top
- Integrated carry handle • Frame: Aluminium
- Table Top: Shower Proof Covered MDF • Size: 60 x 40 cm
- Table Height: 23.5 cm • Folded: 60 x 40 x 3 cm • Weight: 1.48 kg.



Cat No 155102
Superlite Stow Folding Table

Case Pack 6

- Lightweight • Compact • Portable • 2 Heights
- Independent Adjustable, Levelling Feet • Leg Extensions Stow Away
- Folds Away Into a Carry Case • Weave Effect Top • Integrated Carry Handle
- Frame: Aluminium • Size: 120 x 60 cm • Table Height: 55 and 72 cm
- Folded: 60 x 60 x 9.5 cm • Weight: 4.2 kg



Junior and Senior Folding Table

Case Pack 10

- Weather Resistant • Lightweight • Portable • Solid Plastic Top • Powder Coated Steel Frame • Folds Away Easily • Easy to Store • Easy to Clean
- Removable Table Top • Table Size: 52 x 37 cm.
- Junior Dimensions: Height 40cm, Folded: 55 x 52 x 6cm, Weight: 1.6kg.
- Senior Dimensions: Height 70cm, Folded: 80 x 52 x 6cm, Weight: 1.9kg.

Cat No F0015 **White Senior**
Cat No F0017 **White Junior**

Cat No F0016 **Green Senior**
Cat No F0018 **Green Junior**



Quest Elite® Quick Up Range No assembly and Seconds to Erect

The Quest Elite quick up camping range is a range of camping furniture with an exclusive easy to use quick up system that means it only takes seconds to erect your furniture. All these items feature the same 'easy clip' system that means erecting the product is just a case of opening the product out and clipping the hook in place, nothing could be simple or quicker.

There is nothing to assemble, or adjust, just clip the easy clip system in place and you are done.

All the products feature premium quality materials and workmanship. They feature high quality onyx effect shelves, fully zipped and tie backed doors and various different configurations. All the items fold away in seconds and come with their very own high quality carry case making them easy to store and carry.



Scan me to watch the video

Cat No 108000
Medium Cupboard and Storage Unit

Case Pack 6

- 3 High Quality Onyx Effect Shelves
- Strong and Light Coated Steel Frame • Zipped Mesh Front Door
- Front Door Tie Backs • Carry Bag • Fabric: 500D PVC
- Frame: Powder Coated Steel • Size : 62 x 51 x 120 cm
- Folded: 90 x 66 x 12 cm • Weight: 9.6 kg • Max Load: 30 kg.



Scan me to watch the video

Cat No 108001
Large Wardrobe, Cupboard and Storage Unit

Case Pack 6

- Converts from Cupboard to Wardrobe in seconds
- 4 High Quality Onyx Effect Shelves • Inbuilt Hanger for Wardrobe
- Zip Out Shelves • Strong and Light Coated Steel Frame
- Zipped Mesh Front Door • Front Door Tie Backs • Carry Bag
- Fabric: 500D PVC • Frame: Steel • Size : 53 x 51 x 139 cm
- Folded: 90 x 66 x 10 cm • Weight: 8.7 kg • Max Load: 30 kg



Scan me to watch the video

Cat No 108002
Hard Top Camping Larder and Storage Unit

Case Pack 6

- 2 Large High Quality Onyx Effect Shelves • Additional Zipped Storage Pocket • Strong and Light Coated Steel Frame • Zipped Mesh Front Door
- Front Door Tie Backs • Carry Bag • Fabric: 600D PVC
- Frame: Steel • Size : 90 x 51 x 80 cm • Folded: 92 x 66 x 12 cm
- Weight: 10.6 kg • Max Load: 30 kg.



Not part of the Quest Elite Quick up range

Cat No 142720
Quest Steel Camp Bed

Case Pack 6

- Strong • Nothing to Assemble • Folds Out in Seconds
- Just Click the End Poles in Place • Nothing to Adjust
- Folds Away into Small Size • Includes Carry Bag • Easy to Use
- Easy to Store • Frame: Coated Steel • Size: 68 x 194 cm
- Bed Height: 40 cm • Folded: 95 x 20 x 20 cm • Weight: 7.3 kg
- Max Load: kg.



Cat No 118914
Quest Elite® Clamp on Sunshade

Case Pack 48

- Premium Quality • Easy to Use • Large Canopy • Poseable Fixing • Unique Double Fitting Universal Clamp • 8 Ribbed Canopy • High Quality Canopy Fabric
- Anti-glare Canopy Underside • Sprung Loaded Opening Mechanism • Fits almost Any Chair • Can be Used on Prams and Pushchairs
- Shaft: Metal • Fabric: 190T Polyester
- Canopy Size: 68.5 cm. (radius) • Height: 105 cm • Weight 0.3kg



Quest Elite Universal Padded Cushion **Case Pack** 6

- Premium Quality • Extra Comfort • Extra Padding • Adjustable Strap
- Easy Clip Buckle • Size: 125 x 55 cm • Folded: 50 x 23 x 23 cm
- Weight: 0.78 kg.

Cat No 107000 **Grey**
Cat No 107001 **Brown**



Cat No 100029 **Table clip 5 colours (Display pack 20)** **Case Pack** 80 (4 Boxes)

- Can be Used Virtually Anywhere • Holds Glasses or Cans
- Can be used on Tables, Chair arms, Plates and so much more
- Can be used to hang items
- Comes in a ready to use bright, vibrant display box



Cat No 124900 **Case Pack** 6
Quest Elite® Furniture Carry Bag

- Large Enough to Carry Multiple Chairs
- Universal • Showerproof
- Comes in its own Storage Bag
- Fabric: 600D Polyester • Size: 113 x 67 x 18cm
- Folded: 11.5 x 10 x 45cm



Cat No 124901 **Case Pack** 12
Quest Elite® Spare Elastics for Relaxer

- Replacement Elastics for the Quest Elite relaxers
- Strong • Premium Quality
- Quantity: 4 Cords (2 of each size)
- Size: 72 inches and 36 Inches.



Cat No 802413 **Case Pack** 63
Die Cast Car and Caravan

- Car and Caravan Die Cast Childrens Toy
- Car and Caravan can be Separated
- Opening Doors on Car
- Display box of 9 with 3 different combinations
- Outer box contains 2 inner boxes of 4 display boxes (8 in total)

Cat No.	Description	Length	Weights (kg)		
			Roof & Bag	Sides & Poles	Total
154408R	Rollaway 350	350cm	15.3	11.3	26.6
154409R	Rollaway 400	400cm	17.5	12.9	30.4
154410R	Rollaway 450	450cm	19.6	14.5	34.1
107051	25mm Windlock Clamp				
154598	Quest Serial LED Light				
40011	Quest Mains Awning and Camping Light				
Various	For details on the Quest breathable floorings see the mats and matting section				

The Rollaway

The only awning you will ever need

The Rollaway is a state of the art porch awning. The awning stays on the side of your caravan at all times. When you get to your destination, simply unroll the roof, slide out the legs and you have your canopy. It can be used as a canopy only, a standard awning and even a panorama awning where you have both an awning and a covered open area.

The ideal solution for anyone after an easy to use, extremely stable porch awning with additional modes of use.



Panorama Awning Mode



Standard Awning Mode



Sun Canopy Mode



Open Awning Mode

Features

- Roll Out Awning
- Extremely Strong and Stable
- Quick and Easy to Erect
- Sun Canopy Only Mode
- Multiple Panoramic Mode Options
- Only Minutes to Erect
- All Round Easy Clamps
- Tinted Clear View, Anti-Freeze Windows
- One Piece Heat Reflective Roof
- Full Ventilation Side Windows
- 2 Side Doors and 2 Roll Up Front Doors
- Double Pegging Points
- Internal or External Mud Wall

- Extra Weather Straps
- Anti-Weather Roof Valance
- Full internal blinds
- Awning Rail Locking Bolts
- Front Panels can be Rolled Up Independently
- Draft Skirt and Wheel Cover
- Weather and Storm Covers on Zips
- Hidden Roof Pole Protection Pads
- Includes Storm Roof Kit

Materials and Dimensions

- Roof: Heat Reflective PVC
- Walls: 300D Oxford Polyester
- Mudwall: Double Coated PVC Polyester
- Depth: 250 cm
- Height: 250 cm
- Size (length): Depends upon model

Optional Extras

- Questlite Luxury Flooring
- Quest Tredlite Carpet
- Quest Floorlite Universal Flooring
- Quest Awning and Tent Light
- Quest LED Awning Light



The Rollout

The amazing easy roll out of a bag

The Rollout is a state of the art porch awning. The awning stays on the side of your caravan at all times. When you get to your destination, simply unroll the roof, attach the legs and you have your canopy. It can be used as a canopy only or a standard awning, the choice is yours.

The ideal solution for anyone after an extremely easy to use, lightweight porch awning with additional modes of use.

Cat No.	Description	Weight (kg)		
		Roof & Bag	Sides & poles	Total
120012	Rollout 300	5.9	8	13.9
120012K	Rear Pad and Pole Kit			
107052	23mm Windlock Clamp			
154598	Quest Serial LED Light			
40011	Quest Mains Awning and Camping Light			
Various	For details on the Quest breathable floorings see the mats and matting section			



Features

- Quick and Easy to Erect
- Lightweight
- Rolls Away into the Bag
- Stays on Your Van
- Sun Canopy Mode
- Removable Side Panels
- Roll Up Front Panels
- Sun Canopy Panels
- Tinted Windows
- Double Pegging Points
- Full Ventilation Side Doors
- Internal or External Mud Wall
- Awning Rail Locking Bolts

- Draft Skirt and Wheel Cover
- Zip Storm Covers

Materials

- Roof: 190T PU Coated Rip Stop Nylon
- Walls: 190T PU Coated Rip Stop Nylon
- Depth: 230 cm*
- Length: 300 cm*
- Awning Rail Height: 235 – 250 cm*
- Weights:
- Roof and Bag: 5.9 kg*
- Sides and Poles: 8 kg*
- Total: 13.9 kg*

Optional Extras

- Rear Pole and Pad Kit
- Canopy Poles
- Questlite Luxury Flooring
- Quest Tredlite Carpet
- Quest Floorlite Universal Flooring
- Quest Awning and Tent Light
- Quest LED Awning Light



Cat No.	Description	Weights (kg)		
		Canvas	Frame	Total
104095CSG	Quest Elite® Snowdon Awning in Grey	26.8	21.6	48.6
104095W	Snowdon Winter Pole Kit		8	8
107051	25mm Windlock Clamp			
154598	Quest Serial LED Light			
40011	Quest Mains Awning and Camping Light			
Various	For details on the Quest breathable floorings see the mats and matting section			

The Snowdon

All the strength you'll need

The Quest Elite® Snowdon is a fully featured, full season, all year porch awning. It has a modern style with amazing panoramic views and an extremely solid frame design.

The solid frame design, high specification materials and the additional winter pole kit makes this porch awning weatherproof and allows it to be used all year round.



Features

- Quest Tec5 walls and panels
- Extremely Strong Frame Design
- Easy Lock Clamps
- Easy Fit Roof Bracket Pads
- Extra Strong Heat Reflective Roof
- 5 Year anti fade warranty
- Easy to Clean and Maintain
- Clear view, anti smear windows
- Front panel can be rolled up if desired
- Full Ventilation Side Windows
- Extra Strengthening Points and Double Thickness Canvas on all Wear Points
- Awning rail fitment for rear poles
- Ladder Bands and Pegging Toggles

- Colour Coded Draft Skirt & Wheel Cover
- Full Storm Kit Included
- External Quest Tec5 Blinds
- Internal Curtains
- Rear profile triangles
- Extra Guy and Storm Line points
- Fully covered zips
- Zipped Storage Bag for Canvas
- Separate Storage Bag for poles
- In Built Ventilation on Side

Materials and Dimensions

- Roof: Double Coated Extra Strong PVC
- Walls: Quest Tec5 Coated Polyester
- Mud Wall: 510g PVC

- Draft Skirt and Wheel Cover: 510g PVC
- Frame: Steel
- Colour: Two Tone Grey
- Depth: 230cm
- Width: 340cm
- Rear Height: 235 - 250cm
- Canvas Weight: 26.8kg
- Frame Weight: 21.6kg

Optional Extras

- Questex Awning Carpet
- Winter Pole Kit
- Quest Awning and Tent LED Light
- Quest Mains Awning and Tent Light
- Windlock Clamps

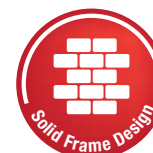

The Kensington Plus

Style and Luxury in One

The Quest Elite® Kensington Plus is a fully featured porch awning that gives full awnings a run for their money. It's the ideal solution for people looking for the simplicity of a porch awning but the luxury and advantages of an extendable full awning.

It features the ease of use of a porch awning along with a host of features usually only found on more expensive full awnings.

Cat No.	Description	Frame	Weights (kg)		
			Canvas	Frame	Total
103616CAG	Kensington Plus alloy awning in grey	Alloy	23.7	9.8	33.5
103616CSG	Kensington Plus steel awning in grey	Steel	23.7	17.9	41.6
103617CSG	Kensington Plus steel extension in grey	Steel	9.0	8.9	17.9
103619	Tall Kensington Plus Extension Inner Tent*				
1041580	Quest Elite Awning Storm Pole Kit (steel)			6	6
104158W	Windsor and Kensington Plus Side Veranda Bar				
107051	25mm Windlock Clamp				
154598	Quest Serial LED Light				
40011	Quest Mains Awning and Camping Light				
Various	For details on the Quest breathable floorings see the mats and matting section				



Shown with optional extension (purchased separately)

Features

- Quest Tec5 walls and panels
- Steel or Alloy frame
- Easy Lock Clamps
- Easy Fit Roof Bracket Pads
- Canopy Poles and Veranda Bar
- Internal Printed and Heat Reflective Roof
- 5 Year Anti Fade Warranty
- Easy to Clean and Maintain
- Clear View, Anti-Freeze Windows
- Full Ventilation Side Windows
- Extra Strengthening Points and Double Thickness Canvas on all Wear Points
- Awning Rail Fitment for Rear Poles
- Ladder bands and Pegging Toggles
- Colour Coded Draft Skirt & Wheel Cover
- Full Storm Kit Included

- Internal Curtains
- Rear Profile Triangles
- Extra Guy and Storm Line Points
- Fully covered zips
- Zipped Storage Bag
- Removable Front and Side Panels
- Switchable Side Panels
- In Built Ventilation on Front

Materials and Dimensions

- Roof: 500d Oxford Polyester
- Walls: Quest Tec5 Coated Polyester
- Mud Wall: 500D Heavy Duty PVC
- Draft Skirt and Wheel Cover: 510g PVC
- Frame: Steel or Alloy
- Colour: Navy and White
- Depth: 230cm

- Width: 340cm
- Rear Height: 235 - 250cm
- Canvas Weight: 23.7kg
- Frame Weight: (Alloy) 9.8kg
- Frame Weight: (Steel) 17.9kg

Optional Extras

- Questex Awning Carpet
- Additional Veranda Bars
- Storm Pole Kit
- Awning Extension
- Awning Extension Inner Tent
- Quest Awning and Tent LED Light
- Quest Mains Awning and Tent Light
- Windlock Clamps



Cat No.	Description	Frame	Weights (kg)		
			Canvas	Frame	Total
104157CA	Windsor Plus alloy awning in blue	Alloy	17.8	8.9	26.7
104157CSG	Windsor Plus steel awning in grey	Steel	17.9	12.7	30.6
1041580	Quest Elite Awning Storm Pole Kit				
104158W	Windsor and Kensington Plus Side Veranda Bar				
107051	25mm Windlock Clamp				
154598	Quest Serial LED Light				
40011	Quest Mains Awning and Camping Light				
Various	For details on the Quest breathable floorings see the mats and matting section				

The Windsor Plus

Luxury in a small size

The Quest Elite® Windsor Plus is a compact, striking porch awning. It is ideal for those looking for a smaller porch awning and those looking for their first porch, yet its advanced materials and features still gives the owner the best possible experience and years of use.

The Windsor Plus is both the perfect starter porch and ideal solution when space is at a premium.



Model Shown : Grey with Steel Frame

Features

- Quest Tec5 walls and panels
- Steel or Alloy frame
- Easy Lock Clamps
- Easy Fit Roof Bracket Pads
- Front Canopy
- Fully Printed Roof
- 5 Year Anti Fade Warranty
- Easy to Clean and Maintain
- Clear View, Anti Freeze Windows
- Extra Strengthening Points and Double Thickness Canvas on all Wear Points
- Awning Rail Fitment for Rear Poles
- Ladder bands and pegging toggles
- Colour coded Draft Skity & Wheel Cover
- Full Storm Kit Included
- Internal Curtains

- Rear Profile Triangles
- Extra Guy and Storm Line Points
- Fully Covered Zips
- Zipped Storage Bag
- Removable Front Panel
- In Built Side Ventilation Points

Materials and Dimensions

- Roof: 500d Fully Printed Oxford Polyester with Heat Reflective Teflon Coating
- Walls: Quest Tec5 Coated Polyester
- Mud Wall: 500D Heavy Duty PVC
- Draft Skirt and Wheel Cover: 510g PVC
- Frame: Steel or Alloy
- Colour: Navy and White
- Depth: 200 cm
- Width: 280cm

- Rear Height: 235 - 250cm
- Canvas Weight: 17.8kg
- Frame Weight: (Alloy) 8.9kg
- Frame Weight: (Steel) 12.7kg

Optional Extras

- Questex Awning Carpet
- Veranda Bars
- Storm Pole Kit
- Quest Awning and Tent LED Light
- Quest Mains Awning and Tent Light
- Windlock Clamps



Easy Cadet

Entry level porch from a high end manufacturer

This is the excellent entry level lightweight 300 porch from the high end Westfield Outdoors manufacturer. You get the same high end production quality and materials but in an entry level package.

The very best balance of value for money and quality in a lightweight, easy to use and roomy porch awning.

Cat No.	Description	Weight (kg)		
		Canvas	Frame	Total
A0001	Easy Cadet	4.7	3.3	8
A0013	Standard Rear Pad and Pole Kit			
A0014	Easy Porch Aluminium Roof Pole Storm Kit			
A0015	Universal Steel Canopy Pole Kit			
154598	Quest Serial LED Light			
40011	Quest Mains Awning and Camping Light			
Various	For details on the Quest breathable floorings see the mats and matting section			



Scan me to
watch the video



Features

- Minimal Frame Design & Zero Tension Frame
- Quick and Easy to Erect
- Large and Roomy inside
- Very Lightweight
- Can be Erected by One Person
- Roll Up and Sun Canopy Front Panel
- Clear View Windows
- Built in Ventilation
- Internal Blinds
- 2 Side Doors
- Large Front and Side Windows
- Hi Vis Guy Lines
- Replaceable Ladder Bands

- Premium Coated Frame
- Draft Skirt and Wheel cover

Materials and Dimensions

- Canvas: 190T PU Coated Polyester
- Mud Skirt : PE Polyester
- Windows: Super Clear Transparent Foil
- HH: 3000mm
- Frame: 19mm Premium Coated Steel
- Width: 280/350 cm.
- Depth: 250 cm.
- Height: 210/245 cm.
- Connection Height: 235-250 cm.
- Folded: 105 x 20 x 20 cm.

- Weight: Frame: 3.3 kg Canvas: 4.7 kg

Optional Extras

- Rear Pad and Pole Kit
- Storm Pole Kit
- Canopy Pole Kit
- Questlite Luxury Flooring and Tredlite Carpet
- Quest Floorlite Universal Flooring
- Quest Awning and Tent Light
- Quest Serial LED Light
- Westfield Outdoors Windshield Pro

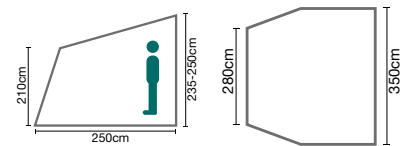

Cat No.	Description	Weight (kg)
A0002	Easy Air 390 Awning	11.5
A0013	Standard Rear Pad and Pole Set	
A0052	Extra Wide Rear Pad and Pole Set	
A0017	Motohome and 390 Aluminium Storm Pole	
A0015	Universal Steel Canopy Pole Kit	
A0016	Inner Tent for Easy Air 390 Awning	
A0018	Replacement Airtube PU Bladder (Easy Air 390 Awning)	
A0019	Replacement Airtube PE Cover (Easy Air 390 Awning)	
154598	Quest Serial LED Light	
40011	Quest Mains Awning and Camping Light	
Various	For details on the Quest breathable floorings see the mats and matting section	

Easy Air 390

Air technology, frame price

This is the stunning new Westfield Outdoors air tube porch. It uses the latest air tube technology and premium manufacturing and production processes to produce an excellent, lightweight air awning that comes with a very surprising price.

Great traditional 390 styled airtube porch and featuring the Westfield Airtube technology. Simplicity and ease of use built in.



Features

- Airtube Frame
- Quick and Easy to Erect
- Can be Erected by One Person
- Roll up and Sun Canopy Front Panel(s)
- 2 Independent Front Panels (large only)
- Clear View Windows
- Built in Ventilation
- 2 Full Ventilation Side Doors
- Large Scenic Windows
- Reflective Storm Straps
- Internal Blinds
- Draft Skirt and Wheel Cover
- Dual Size Awning Beading
- Pump with Auto cut off Valve

Materials and Dimensions

- Canvas: 190T PU Coated Polyester
- Mud Skirt : PE Polyester
- Windows: Super Clear Transparent Foil
- HH: 3000mm
- Frame: Triple Layered Airtube (frameless)
- Width: 390 cm.
- Depth: 235 cm.
- Awning Rail Height: 235-250 cm.
- Folded: 85 x 40 x 25 cm.
- Weight: 11.5 kg

Optional Extras

- Inner Tent
- Replacement Tubes

- Rear Pad and Pole Kit
- Canopy Pole Kit
- Storm Pole Kit
- Westfield Outdoors Windshield Pro
- Quest Serial LED Light
- Quest Flooring (various)

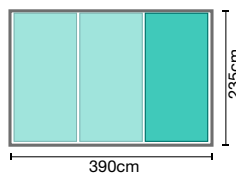
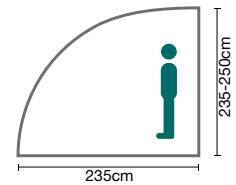

Easy Air 280 and 350

Air technology, frame price

This is the stunning new Westfield Outdoors air tube porch. It uses the latest air tube technology and premium manufacturing and production processes to produce an excellent, lightweight air awning that comes with a very surprising price.

Available in two different sizes and featuring the Westfield Airtube technology. Simplicity and ease of use built in.

Cat No.	Description	Weight (kg)
A0004	Easy Air 280 Awning	6.2
A0005	Easy Air 350 Awning	7.2
A0013	Standard Rear Pad and Pole Set	
A0052	Extra Wide Rear Pad and Pole Set	
A0014	Easy Porch Aluminium Roof Pole Storm Kit	
A0054	Easy 350 Storm Leg Pole	
A0015	Universal Steel Canopy Pole Kit	
A0020	Replacement Airtube PU Bladder (Easy Air 280 Awning)	
A0021	Replacement Airtube PE Cover (Easy Air 280 Awning)	
A0022	Replacement Airtube PU Bladder (Easy Air 350 Awning)	
A0023	Replacement Airtube PE Cover (Easy Air 350 Awning)	
154598	Quest Serial LED Light	
40011	Quest Mains Awning and Camping Light	
Various	For details on the Quest breathable floorings see the mats and matting section	



Scan me to watch the video

Features

- Airtube Frame
- Quick and Easy to Erect
- Can be Erected by One Person
- Roll up and Sun Canopy Front Panel(s)
- 2 Independent Front Panels (large only)
- Clear View Windows
- Built in Ventilation
- 2 Full Ventilation Side Doors
- Large Front and Side Windows
- Reflective Storm Straps
- Internal Blinds
- Draft Skirt and Wheel Cover
- Dual Size Awning Beading
- Pump with Auto cut off Valve

Materials and Dimensions

- Canvas: 190T PU Coated Polyester
- Mud Skirt : PE Polyester
- Windows: Super Clear Transparent Foil
- HH: 3000mm
- Frame: Triple Layered Airtube (frameless)

Sizes (Medium)

- Width: 225/280 cm.
- Depth: 225 cm.
- Awning Rail Height: 235-250 cm.
- Folded: 85 x 25 x 25 cm.
- Weight: 6.2 kg

Sizes(Large)

- Width: 280/350 cm.
- Depth: 250 cm.

- Awning Rail Height: 235-250 cm.
- Folded: 95 x 30 x 25 cm.
- Weight: 7.2 kg

Optional Extras

- Replacement Tubes
- Rear Pad and Pole Kit
- Canopy Pole Kit
- Storm Pole Kit
- Westfield Outdoors Windshield Pro

A0004: Medium Easy Porch

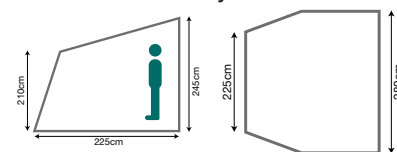

A0005: Large Easy Porch

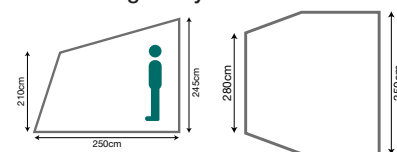

Cat No.	Description	Weight (kg)
A0006	Easy Air 310 Motorhome Awning	9.8
A0017	Easy Air 390, 310 and 510 Aluminium Storm Pole	
A0015	Universal Steel Canopy Pole Kit	
A0024	Inner Tent for Easy Air 310 Motorhome Awning	
A0025	Replacement Airtube PU Bladder (Easy Air 310 Motorhome Awning)	
A0026	Replacement Airtube PE Cover (Easy Air 310 Motorhome Awning)	
154598	Quest Serial LED Light	
40011	Quest Mains Awning and Camping Light	
Various	For details on the Quest breathable floorings see the mats and matting section	

Easy Air 310 Motorhome

Air technology, frame price

This is the stunning new Westfield Outdoors air tube motorhome awning. For use with low motorhomes and vans. Lightweight and stand alone

For connection heights of 1.8 - 2.2m and featuring the Westfield Airtube technology. Simplicity and ease of use built in.



Scan me to watch the video



Features

- Airtube Frame
- Quick and Easy to Erect
- Can be Erected by One Person
- Can be Used as Standalone Awning
- Large Front Sun Canopy Door
- Side Sun Canopy Door
- Built In Ventilation
- Reflexive Storm Straps
- Internal Blinds
- Sewn in Groundsheet
- Clear View Windows
- Pump with Auto Cut off Valve
- Triple Point Tunnel Connection System
- Optional Inner Tent Available (purchased separately)

Materials and Dimensions

- Canvas: 190T PU Coated Polyester
- Mud Skirt : PE Polyester
- Windows: Super Clear Transparent Foil
- HH: 3000mm
- Frame: Triple Layered Airtube (frameless)
- Width: 315 cm.
- Depth: 340 cm.
- Height: 205 cm.
- Tunnel Size
- Width: 310cm
- Depth: 90cm
- Connection Height: 180 - 245 cm.
- Folded: 85 x 20 x 20 cm.
- Weight: 9.8kg.

Optional Extras

- Inner Tent
- Replacement Tubes
- Canopy Pole Kit
- Storm Pole Kit
- Westfield Outdoors Windshield Pro
- Quest Serial LED Light
- Quest Flooring (various)

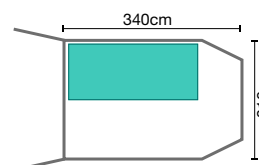
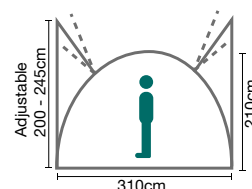

Easy Air 510 Motorhome

A tent and motorhome awning in one

This is the stunning new westfield outdoors air tube bus tent. It uses the latest air tube technology and premium manufacturing and production processes to produce an excellent, lightweight awning that comes with a very suprising price.

Multiple uses as it can be used as a tent or motorhome awning. Simplicity and ease of use built in.

Cat No.	Description	Weight (kg)
A0008	Easy Air 510 Motorhome Awning	13
A0010	Low Top Connection Kit for Easy Air 510 Motorhome Awning (180 - 245 cm)	
A0011	High Top Connection kit for Easy Air 510 Motorhome Awning (245 - 280 cm)	
A0017	Easy Air 390, 310 and 510 Aluminium Storm Pole	
A0015	Universal Steel Canopy Pole Kit	
A0027	Inner Tent for Easy Air 510 Motorhome Awning	
A0028	Replacement Airtube PU Bladder (Easy Air 510 Motorhome Awning)	
A0029	Replacement Airtube PE Cover (Easy Air 510 Motorhome Awning)	
154598	Quest Serial LED Light	
40011	Quest Mains Awning and Camping Light	
Various	For details on the Quest breathable floorings see the mats and matting section	



Scan me to watch the video

Features

- Airtube Frame
- Quick and Easy to Erect
- Can be Erected by One Person
- Can be Used as a Family Tent
- Can be Used as Standalone Awning
- Large Front Sun Canopy Door
- 2 Side Sun Canopy Doors
- Built In Ventilation
- Refelctive Storm Straps
- Removable Vehicle Connecting Tunnel
- Internal Blinds
- Sewn in Groundsheet
- Clear View Windows
- Pump with Auto Cut off Valve
- Triple Point Tunnel Connection System

- Optional Inner Tent Available (purchased separately)

Materials and Dimensions

- Canvas: 190T PU Coated Polyester
- Mud Skirt : PE Polyester
- Windows: Super Clear Transparent Foil
- HH: 3000mm
- Frame: Triple Layered Airtube (frameless)
- Width: 290 cm.
- Depth: 510 cm.
- Height: 210 cm.
- Connector Sizes
- Width: xxx cm.
- Depth: xx cm.
- Low Connector: 180 - 245 cm.

- High Connector: 245 - 280 cm.
- Folded: 80 x 40 x 40 cm.
- Weight: 13 kg.

Optional Extras

- Inner Tent
- Replacement Tubes
- Canopy Pole Kit
- Storm Pole Kit
- Westfield Outdoors Windshield Pro
- Quest Serial LED Light
- Quest Flooring (various)

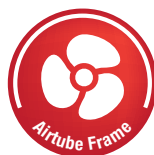
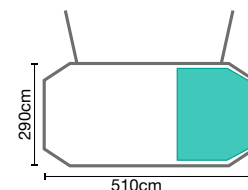
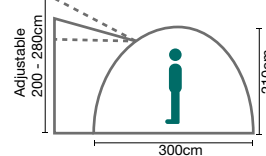

Cat No.	Description	Weight (kg)
120051	Quest Elite Instant Spring Up Screen House 6	15.5
120052	Optional Sidewall Blinds for the Screen House 6 (one pair)	
4598	Quest 120 LED Awning, Tent and Gazebo lighting	
Various	For details on the Quest breathable floorings see the mats and matting section	

The Screen House 6 1 Person, 1 Minute

This is the excellent Quest Elite Instant Spring Up Screen House 6. This is a multi-use gazebo, screen house or event shelter. It is perfect for entertaining in the garden, away at events, a covered social area when camping, in fact the uses are almost limitless.

The screen house features the unique spring up frame system which allows 1 person to erect this screen house in under a minute. There is no frame to erect, nothing to put together or adjust, it goes up in three simple steps.



Scan me to watch the video

Features

- 6 Sided Gazebo, Screen House or Event Shelter
- Premium Quality
- Goes up in Under 1 Minute
- 5 Fully Screened Sides
- 1 x Fully Screened Double Door
- Storm Straps Included
- Waterproof Roof
- Highest UV Rating Possible
- Can be fitted with optional side wall blinds.
- Huge Internal Space
- Large Enough to accommodate 6 piece patio set

Materials and Dimensions

- Canvas: 210D PU Coated Oxford Polyester
- UV Rating: 50+
- HH: 1000mm
- Frame: Fibreglass
- Side Size : 183 x 210
- Floor Size: 350 x 350
- Height: 210 cm
- Folded: 185 x 18 x 18
- Weight: 15.5 kg

Optional Extras

- Questex Awning Carpet
- Sidewall Blinds
- LED Awning and Camping Lights



The Screen House 4

1 Person, 1 Minute

This is the excellent Quest Elite Instant Spring Up Screen House 4. This is a multi-use gazebo, screen house or event shelter. It is perfect for entertaining in the garden, away at events, a covered social area when camping, in fact the uses are almost limitless.

The screen house features the unique spring up frame system which allows 1 person to erect this screen house in under a minute. There is no frame to erect, nothing to put together or adjust, it goes up in three simple steps.

Cat No.	Description	Weight (kg)
120053	Quest Elite Instant Spring Up Screen House 4	11.5
120054	Optional Sidewall Blinds for the Screen House 4 (one pair)	
154598	Quest Serial LED Light	
Various	For details on the Quest breathable floorings see the mats and matting section	



Scan me to watch the video

Features

- 4 Sided Gazebo, Screen House or Event Shelter
- Premium Quality
- Goes up in Under 1 Minute
- 5 Fully Screened Sides
- 1 x Fully Screened Double Door
- Storm Straps Included
- Waterproof Roof
- Highest UV Rating Possible
- Can be fitted with optional side wall blinds.
- Large Internal Space
- Large Enough to accommodate 4 piece patio set

Materials and Dimensions

- Canvas: 210D PU Coated Oxford Polyester
- UV Rating: 50+
- HH: 1000mm
- Frame: Fibreglass
- Side Size : 244 x 210
- Floor Size: 244 x 244
- Height: 210 cm
- Folded: 167 x 16 x 16
- Weight: 11.5 kg

Optional Extras

- Questex Awning Carpet
- Sidewall Blinds
- LED Awning and Camping Lights



Cat No.	Description	Weight (kg)
150100	Pathfinder wireless automatic roof tent	53
4598	Quest Awning and Camping LED Light	
40011	Quest Mains Awning and Camping Light	

Pathfinder Wireless Automatic Roof Tent

Incredible features and quality

This is the incredible automatic roof tent. You simply get out of your vehicle, press the button on the wireless remote and your tent is ready. It is extremely comfortable and comes with its own high comfort foam mattress already in place. Packed full of features and excellent build quality this is a high performance product full of that wow factor.



Features

- Seconds to erect
- One click of the remote and it is done.
- 100% Waterproof Flysheet
- Premium quality
- Wireless remote
- In built 12V socket
- Extra Comfort Mattress
- Aluminium Ladder
- Large front Canopy
- Waterproof Cover when tent not in use

Materials and Dimensions

- Canvas: Silver Coated Polyester
- Cover: 600G PVC
- UV Rating: 50+
- HH: 2000 mm
- Frame: Aluminium
- Joints: Stainless Steel
- Size: 210 x 125 x 115 cm.
- Folded: 230 x 145 x 32 cm.
- Weight: 53kg. (including ladder 7kg)

Optional Extras

- Quest Awning and Tent LED Light
- Quest Mains Awning and Tent Light



Instant Erect Shelters

Seconds to erect, packed with features

Here are the new range of instant shelters. Great for use in the garden, at the beach, whilst camping, caravanning, at a show the list is endless.

All feature a unique easy to use frame system that only takes seconds to erect, with nothing to assemble, tension or adjust.

Cat No.	Description	Weight (kg)
120061	Instant Beach Star Beach Shelter	2.1
120060	Instant Summer palace Beach Shelter	3.3



Cat No 120061
Instant Beach Star Beach Shelter

Case Pack 9

- Easily Erected in Seconds • Nothing to Assemble
- Frame and Canvas Combined • Simply Unfolds Straight Out of the Bag
- Easy Erect Frame • Very Small Folded Size
- Pegging Points and Sand Bag Ground Attachment • 2 Fully Covered Sides
- Frame: Solid Fibreglass • Size: 150 x 220 cm. • Height: 120 cm.
- Folded: 80 x 25 x 20 cm. • Weight: 2.1 kg.



Cat No 120060
Instant Summer Palace Beach Shelter

Case Pack 6

- Easily Erected in Seconds • Nothing to Assemble
- Frame and Canvas Combined • Simply Unfolds Straight Out of the Bag
- Easy Erect Frame • Front Sheet Can Be Used as Privacy Cover on Front
- Built in Ventilation • Pegging Points and Sand Bag Ground Attachment
- 3 Fully Covered Sides
- Frame: Solid Fibreglass • Size: 260 x 170 (+90) cm. • Height: 155 cm.
- Folded: 120 x 20 x 15 cm. • Weight: 3.3 kg.



Cat No 4400
Quest Pop up Gazebo

Case Pack 6

- Lightweight • Easy to Use • Shower Proof • Includes Carry Bag
- Includes Guide Rops and Pegs • Optional Side Walls
- Cover: 160g Polyester • Frame: Steel 25 x 25 / 20 x 20 / 10 x 18mm.
- Size: 300 x 300cm • Height: 250cm



Cat No 4401
Pair of Side Walls for the Quest Pop up Gazebo

Case Pack 6

- Lightweight • Easy to Use • Shower Proof • Eyelets Along the Bottom
- Velcro Loops at Top • Fabric: 140g Polyester.
- Length: 300cm • Height: 250cm

The Instant Utility Utility, Storage and Shower

The Instant Utility and Storage tent is a multi-use item that is a great storage or utility tent, but can also be used as a shower tent if required.

It has the patented zero tension frame (ZTF) which means there are no poles or canvas to tension, no frame to inflate, just a couple of poles to lock in place and the tent is ready to peg.

Cat No.	Description	Weight (kg)
120010	Instant Utility and Storage Tent	5.5
154598	Quest Serial LED light	
40011	Quest Mains Awning and Camping Light	



Features

- High Quality Materials
- Patented Instant Erect Frame System
- Zero Tension Frame
- Entire Tent is in One Bag
- Durable Coating on Frame
- In Built Removable Groundsheet
- Zipped Front Door
- Carry Bag
- Can be used as Shower Tent
- Holder for Shower Unit
- Multi-Purpose Uses

Materials and Dimensions

- Colour: Blue and Grey
- Canvas: 190T Polyester PU Coated
- Floor: 120G PE Coated
- Top Frame: Fibreglass Poles
- Lower Frame: Steel pole with Durable Coating
- Size: 155 x 155 x 205 cm
- Folded Size: 105 x 17 x 17 cm
- Weight: 5.5 kg. (Total weight including carry bag)

Optional Extras

- Quest Awning and Tent LED Light
- Quest Mains Awning and Tent Light

Erected in seconds in 3 Easy Steps

1. Take out of the bag and unfold.
2. Set the roof
3. Extend legs



The Kensington Plus Extension

A Luxury Addition

The Quest Elite® Kensington Plus extension is a full specification extension for the excellent Kensington Plus awning.

Made from the same high quality materials as the awning it is the perfect addition to your awning.

Cat No.	Description	Frame	Weights (kg)		
			Canvas	Frame	Total
103617CSG	Kensington Plus steel extension in grey	Steel	9.0	8.9	17.9
103619	Tall Kensington Plus Extension Inner Tent*				
154598	Quest Serial LED Light				
40011	Quest Mains Awning and Camping Light				
Various	For details on the Quest breathable floorings see the mats and matting section				



Features

- Quest Tec5 walls and panels
- Alloy frame
- Easy Lock Clamps
- Internal Printed and Heat Reflective Roof
- 5 Year Anti Fade Warranty
- Easy to Clean and Maintain
- Clear View, Anti-Freeze Windows
- Full Privacy Windows
- Extra Strengthening Points and Double Thickness Canvas on all Wear Points
- Ladder bands and Pegging Toggles
- Fully covered zips
- Zipped Storage Bag
- In Built Ventilation

Materials and Dimensions

- Roof: Double coated, Heat Reflective PVC.
- Walls: Quest Tec5 Coated Polyester.
- Mud Wall: 510g PVC.
- Frame: Steel.
- Colour: Navy and White.
- Depth: 200 cm.
- Width: 200 cm.
- Height: 150 cm.
- Canvas: 9.0 kg.
- Frame: 8.9 kg.

Optional Extras

- Questex Awning Carpet
- Awning Extension Inner Tent
- Quest Awning and Tent LED Light
- Quest Mains Awning and Tent Light
- Windlock Clamps

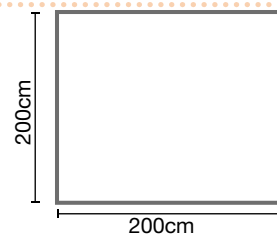
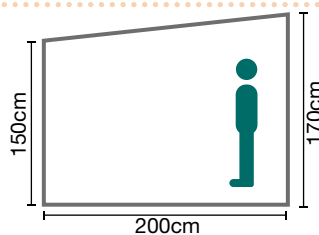

Cat No 4067

Quest Traveller Toilet Tent

The toilet tent is made from lightweight material so it is extremely light in weight. The lightweight nature makes it easier to erect and helps keep the weight down in your car or caravan. It is extremely easy to use. It only has two poles to put together and comes complete with pegs and guylines so it is extremely easy to erect. The toilet tent features a zipped front door which means you can close and open the door fully depending upon your requirements. The use of a fully zipped door means that you can close it and keep all the insects and bugs out. It also features built in ventilation which aids air flow and helps keep the internal area more comfortable. It also means that you can close the door even on a hot day which keeps the insects and bugs out, but the ventilation keeps it cool.

- Lightweight • Easy to Use • Zipped Door • In Built Ventilation • Carry Bag
- 1 x Polyester Canvas • 1 x Peg Bag • 6 x Metal Pegs • 2 x Guylines • 1 x Pole Bag
- 2 x Fibreglass poles • 1 x Carry Bag
- Size: 120 x 120 cm • Height: 225 cm • Packed Size: 10 x 15 x 60 cm • Weight: 2.1 kg

Case Pack 6



Cat No 103619

Kensington Plus Extension Inner Tent

Premium quality inner tent for use with the Quest Elite Kensington Plus Extension. Made from premium quality materials this inner tent simply clicks onto the frame of the Kensington Plus Extension and then pegs into the ground. It gives extra privacy and protection when using the extension. Features built in ventilation, zipped door and comes complete with its own zipped carry bag.

The inner tent features a zipped front door which means you can close and open the door fully depending upon your requirements. The use of a fully zipped door means that you can close it and keep all the insects and bugs out.

- Built In Ventilation • Fully Zipped Door • Pegging Points • Easy to Use Pole Clips
- Zipped Carry Bag
- Size: 180 x 180 cm. • Height: 135 cm. • Packed Size: 60 x 15 x 15 cm. • Weight: 2 kg.

Case Pack 6

Cat No 4068

Quest Universal 3 Berth Inner Tent

A high quality, fully enclosed inner tent. This inner tent can be fitted to a large number of tents or awnings (Additional fixings may be required.). It has 19mm pole clips on elastic hoops which can be fitted direct to your poles. If these do not fit you can use your own fixings along with the elastic loops to attach it to anything available. It comes complete trayed groundsheet. This means that the durable, waterproof groundsheet comes up around the sides of the inner tent which ensures that no water can run into the inner tent.

- High Quality • Lightweight • Universal Fit • Trayed Groundsheet • Zipped Storage Bag
- In built ventilation • Zipped door • Polyester Canvas • Fibreglass Poles
- 1 x Inner Tent • 1 x Peg Bag • 8 x Metal Pegs • 1 x Storage Bag • Size: 200 x 180 cm
- Height: 175 cm • Packed Size: 40 x 30 x 18 cm • Hanging Clips: 19 mm • Weight: 1.1 kg

Case Pack 6



Stock image



Stock image

Cat No 4070

Quest Universal 2 Berth Inner Tent

A high quality, fully enclosed inner tent. This inner tent can be fitted to a large number of tents or awnings (Additional fixings may be required.). It has 19mm pole clips on elastic hoops which can be fitted direct to your poles. If these do not fit you can use your own fixings along with the elastic loops to attach it to anything available. It comes complete trayed groundsheet. This means that the durable, waterproof groundsheet comes up around the sides of the inner tent which ensures that no water can run into the inner tent.

- High Quality • Lightweight • Universal Fit • Trayed Groundsheet • Zipped Storage Bag
- In built ventilation • Zipped door • Polyester Canvas • Fibreglass Poles
- 1 x Inner Tent • 1 x Peg Bag • 8 x Metal Pegs • 1 x Storage Bag • Size: 200 x 135 cm
- Height: 175 cm • Packed Size: 40 x 30 x 18 cm • Hanging Clips: 19 mm • Weight: 1 kg

Case Pack 6



Westfield Outdoors Original Inner Tents

These inner tents are made specifically for the new Easy Air awnings so you know that they will fit, work well and cause no issues with your awning.

They are made to the same high standards that the Easy Air awnings are and fit with your awnings style and use..



Cat No A0016

Case Pack 6

Easy Air 390 Porch Awning Inner Tent

For use with the Easy Air 390 porch awning. It simply clips into place using the built in clips in the awning. You can have 2 inner tents in one Airtube porch and they can be positioned in any of the three sections. It has a sewn in groundsheet, built in ventilation and 2 fully zipped doors. Due to the 2 fully zipped doors you can still use the side doors on the awning even when the inner tent is in place.

The inner tent has 4 pockets on the inside giving you useful extra storage inside the inner tent. The easy to use colour coded clip system makes it extremely easy to fit and anyone can fit the inner tent in seconds. The breathable material and built in ventilation ensures it is as comfortable as possible inside the inner tent, whilst the sewn in groundsheet gives you extra protection against the ground.

- Breathable • In Built Ventilation • Fits in Seconds • 2 Zipped Doors • Full Sewn in groundsheet
- Internal Storage Pockets
- Fabric: Breathable Polyester • Groundsheet: PE Sheet
- Size: 210 x 130 cm. • Packed Size: 42 x 14 x 16 cm. • Weight: 2.8 kg.

Cat No A0027

Case Pack 6

Easy Air 510 Motorhome Awning and Family Tent Inner Tent

For use with the Easy Air 390 motorhome awning and family tent. It simply toggles into place using the built in loops in the awning and toggles on the inner tent. It takes up the entire end of the awning and has a partition wall in the middle giving you two separate sleeping areas. The partition wall can be moved aside to leave you with one large internal area if you wish. It has a sewn in groundsheet, built in ventilation and 2 fully zipped doors.

The inner tent has front facing pockets on the giving you useful extra storage on the inner tent. The easy to use colour coded toggle system makes it extremely easy to fit and anyone can fit the inner tent in seconds. The breathable material and built in ventilation ensures it is as comfortable as possible inside the inner tent, whilst the sewn in groundsheet gives you extra protection against the ground.

- Breathable • In Built Ventilation • Fits in Seconds • 2 Zipped Doors
- Full Sewn in groundsheet • Storage Pockets • Movable Partition Wall
- Fabric: Breathable Polyester • Groundsheet: PE Sheet
- Size: 270 x 205 x 200 cm. • Packed Size: 40 x 17 x 17 cm. • Weight: 4.8 kg



Cat No A0024

Case Pack 6

Easy Air 310 Motorhome Awning Inner Tent

For use with the Easy Air 390 motorhome awning. It simply toggles into place using the built in loops in the awning and toggles on the inner tent. It takes up one side of the awning so the awning can easily be used even when the inner tent is in use, but still gives you a large area inside the inner tent. It has a sewn in groundsheet, built in ventilation and 2 fully zipped doors.

The inner tent has internal storage pockets giving you useful extra storage inside the inner tent. The easy to use colour coded toggle system makes it extremely easy to fit and anyone can fit the inner tent in seconds. The breathable material and built in ventilation ensures it is as comfortable as possible inside the inner tent, whilst the sewn in groundsheet gives you extra protection against the ground.

- Breathable • In Built Ventilation • Fits in Seconds • Fully Zipped Door
- Full Sewn in groundsheet • Storage Pockets
- Fabric: Breathable Polyester • Groundsheet: PE Sheet
- Size: 210 x 130 cm. • Packed Size: 40 x 16 x 14 cm. • Weight: 3.1 kg.

Westfield Outdoors® Windshield Pro High End Extendable Windshield

This is the excellent new windshield pro from Westfield Outdoors. It is a high end windbreak that can be extended to any size and features a unique frame system that is easier to erect than its guy line counterparts and removes the need for guylines which usually take you a large part of your available space.

Use all of your space, extend your windsheld to any size, connect it to your van and look great ..

Cat No.	Description
A0033	Windshield Pro (3 Panels)
A0034	Additional Panel
A0035	Caravan Awning Rail Connector



Features

- Protection from the Sun and Wind
- Extendable to any size
- Premium Quality
- Fits in with the excellent new Westfield range design
- Unique pole system does away with the need for guylines
- Use 100% of your space
- Easier to erect than guy line versions
- Strong and sturdy
- Floor plates
- Steel pegs

Materials and Dimensions

- Canvas: 210D PU Coated Oxford Polyester
- Windows: Superclear transparent foil
- HH: 1000mm
- Frame: Aluminium with oxidized frosting coating.

Optional Extras

- Additional Panels
- Awning Rail Connector

Sizes

Windshield Pro

- Length: 480 cm.
- Height: 130 cm..
- Folded: 110 x 25 x 15 cm.
- Weight: 5.9 kg

Additional Panel

- Length: 160 cm.
- Height: 130 cm..
- Folded: 110 x 15 x 10 cm.
- Weight: 2.2 kg

Caravanstore Easy Room

Alternate panels for a caravanstore zip

At last there is an alternative to the stock fiamma caravanstore panels. These panels look better than the originals and are made to the same high standards that the rest of the Westfield Outdoors range are.

The perfect blend of Fiamma fitting and Westfield improvements. They can be used with both the caravanstore and caravanstore zip products.

Cat No.	Description
A0038	Easy Room 310 Front Panels
A0039	Easy Room 360 Front Panels
A0040	Easy Room 410 Front Panels
A0041	Easy Room 4409 Front Panels
A0042	Easy Room Side Panels
A0043	Easy Room 310 Front Panel Curtains
A0044	Easy Room 360 Front Panel Curtains
A0045	Easy Room 410 Front Panel Curtains
A0046	Easy Room 440 Front Panel Curtains
A0047	Easy Room Side Panel Curtains

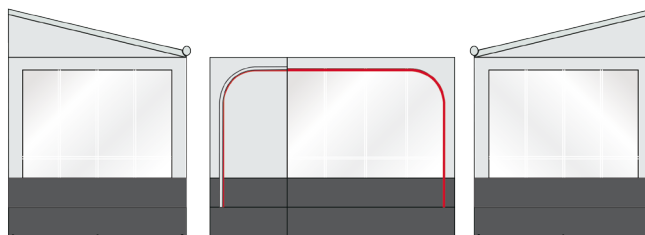

Features

- Premium Quality
- More stylish than the originals
- Fits in with the excellent new Westfield range design
- Universal sides
- Large windows for better views
- Roomier feel due to larger windows
- Strong storm strap system

Materials and Dimensions

- Canvas: 210D PU Coated Oxford Polyester
- Windows: Superclear transparent foil
- HH: 1000mm

Optional Extras

- Curtains
- LED Awning and Camping Lights
- Westfield Outdoors Windshield Pro

Sizes

Sides (Universal)

- Depth: 215 cm.
- Height: 210/260 cm.
- Folded: 144 x 24 x 19 cm
- Weight: 10 kg

Easy Room 310 Front Panel

- Width: 285 cm.
- Height: 210 cm..
- Folded: 86 x 15 x 17 cm.
- Weight: 6.3 kg

Easy Room 360 Front Panel

- Width: 335 cm.
- Height: 210 cm..
- Folded: 86 x 17 x 17 cm.
- Weight: 7 kg

Easy Room 410 Front Panel

- Width: 385 cm.
- Height: 210 cm..
- Folded: 86 x 18 x 18 cm.
- Weight: 7.5 kg

Easy Room 440 Front Panel

- Width: 415 cm.
- Height: 210 cm..
- Folded: 86 x 18 x 18 cm.
- Weight: 8 kg



Cat No A0064 **Case Pack 3**
Spiral 40cm Screw Stake

- High Quality • Solid Steel • Secure Staking Point
- Easy To Use • 360 Degree O-ring
- Length: 40 cm. • Diameter: 8mm.
- Display Box of 20



Cat No A0065 **Case Pack 3**
Solid Steel U Shape Anchor

- High Quality • Solid Steel • Extremely Strong
- Extremely Strong Anchor Point • Easy To Use
- Height: 40 cm. • Diameter: 18mm.
- Display Box of 8



Cat No A0066 **Case Pack 3**
Red Topped Twisted Screw Pegs

- High Quality • Very Strong • High Visibility Top
- Screws into Ground for Extra Grip • Easy To Use
- Hand Grip • Length: 20 cm. • Diameter: 7mm.
- Display Box of 50



Cat No A0067 **Case Pack 3**
Red Plastic Tent and Awning Peg

- High Quality • Easy To Use • Easy to Remove
- High Quality Plastics • Dual Hook Points
- Cross Section Shaft
- Length: 19 cm. • Diameter: 15mm.
- Display Box of 100



Cat No A0068 **Case Pack 3**
Glow in the Dark Solid Metal Peg

- High Quality • Easy To Use • Easy to Remove
- Solid Metal Shaft • Glow in the Dark Head
- Anchor Point in Head
- Length: 25 cm. • Diameter: 7mm.
- Display box of 200



Cat No A0069 **Case Pack 3**
High Visibility Groundsheet Peg

- High Quality • Easy To Use • Easy to Remove
- High Visibility • Peg Extractor Point
- Length: 8 cm. • Diameter: 5mm.
- Display Box of 200



Cat No A0070 **Case Pack 3**
Black Topped Screw Pegs

- High Quality • Very Strong
- Screws into Ground for Extra Grip • Easy To Use
- Hand Grip • Length: 20 cm. • Diameter: 7mm.
- Display Box of 50



Rear Pad and Pole Kits **Case Pack 2**

- Help give a better seal against your caravan
- Helps Stop Draughts
- Helps Protect Your Van

Cat No	Model
A0013	Easy Air 280, 350 and 390 Standard Rear Pad and Pole Kit
A0052	Easy Air 280, 350 and 390 Extra Wide Rear Pad and Pole Kit
A0053	Caravanstore Easy Room Rear Pad and Pole Kit
120012K	Rollout 300 Rear Pad and Pole Kit

Registered Design



Cat No 107051 **Quest Elite 25mm Windlock Clamp (Bag of 5)**
Cat No 107052 **Quest Elite 22mm Windlock Clamp (Bag of 5)**

• Easy Lock Clamp • Additional Thumb Screw Lock • High Quality Plastic Reinforced with Carbon Fibre • Length: 9 cm • Height: 5 cm • Fit: 25mm Poles

Cat No **Description**

Awning, Porch and Tent Accessories

Quest Awning and Camping LED Light

Case Pack 10

154598 Low wattage, excellent quality LED light. Suitable for most caravan awnings, tents, porches and gazebos (some extra fittings may be required). Fits all Quest Elite awnings, porches and lightweights. Comes with 2 double clips for fitting to poles and an extra long 5m power cable. Dual voltage capability with mains plug and cigarette lighter adapter included. CE marked and RoHS compliant. Voltage: 12v/240v , Light Length 120 cm , Cable Length: 5m.

Quest Mains Awning and Camping Light

Case Pack 10

40011 Light specifically designed for awnings and tents. It has connectors for use with poles and a hook for use in a tent. Comes complete with an extra long mains cable to make it easy to use wherever you need it. Cable Length: 6m , Light Size: 20 x 10 x10 cm.

Quest Elite Snowdon Winter Pole Kit

Case Pack 5

104095W A winter pole kit for the Quest Elite Snowdon porch awning. It features five extendable poles which attach to the existing frame giving extra support and rigidity to the frame for those stormier days and winter weather. Ideal for stormy and winter weather or added support if you're leaving your awning for a few days without supervision. All poles feature easy lock clamps and rubber non slip/non scratch ends to ensure that the kit is easy to fit and will not scratch your existing poles or slip once in place. 1 Pole consisting of pole numbers 9, 10 and 17 , 2 Poles consisting of pole numbers 13 and 14 , 2 Poles consisting of pole numbers 15 and 16.

Quest Elite Awning Storm Pole Kit

Case Pack 5

1041580 A storm pole kit for the Quest Elite Kensington Plus and Windsor Plus awnings. It consists of 4 poles with can be used to further strengthen the Kensington Plus and Windsor Plus models. The poles slide into the sleeves on the Kensington Plus and Windsor Plus panels and clamp onto the existing frame. The exclusive non-slip clamps mean that not only grip well but do not mark the frame poles at all. Once in place they make your awning stronger, more rigid and better protected against the more severe weather, an essential addition for those that use their awning during all weather. 2 Poles consisting of pole numbers 18,19 and 20 , 2 Poles consisting of pole numbers 16 and 17.

Windsor and Kensington Plus Side Veranda Bar

Case Pack 5

104158W High quality steel veranda bar. Features non slip connectors at either end and a quick clamp to allow ease of use and quick fitting. Can be used on either side of a Kensington Plus or Windsor Plus porch awning.

Awning tie down kit

Case Pack 10

7035 A high quality tie down kit for awnings and tents. Featuring an extra long strap to allow it to fit awnings and tents up to 6m wide. Helps to secure awnings and tents in adverse weather conditions. Includes large strong metal springs to allow movement and help stop ripping, but still helps keep your awning or tent secured to the ground. Fits awnings up to 6m , Overall Length: 11m.

Tent Peg Extractor

Case Pack 10

7039 Easy to use Hooks under peg to remove the strain of pulling

Awning Rail Zip Lubricant & General Maintenance Spray

Case Pack 4

7080 Easy to use general maintenance and awning lubricant spray. Is an excellent lubricant for awning rails, use on rubber seals and other general maintenance uses. It is colourless, odourless, non-staining and non-tainting so it can be used on a variety of surfaces and materials. It can be used as a release or anti-stick agent on plastic injection moulding, fibreglass moulding, footwear industry, ceramicware production, rubber articles and oven shelves (not in excess of 315 degrees centigrade). It can also be used as an instant spray gloss application for PVC, upholstery, rubber and plastic trim, wood and metal surfaces. It can also be used as a general lubrication spray for most plastic, synthetic/natural rubber or plastic bearing, textiles fibres and more.

Cat No Description

Awning and Porch Replacement Parts

1041501	<p>Quest Elite Small Quick Lock Pole Clamp Case Pack 5</p> <p>A set of 2 small quick lock pole clamps. Easily slides over the end of your pole. Quick lock clamp ensures that it's easy to use and the pole is locked into place once used. Can be used with any 22mm diameter poles. 100% Compatibility with Quest Elite Kensington Plus canopy poles and Kensington Plus extension.</p>
1041502	<p>Quest Elite Roof Pole Brackets Case Pack 5</p> <p>A set of 3 black roof pole brackets. These brackets ensure that your awnings roof poles sit against the side of your van securely and do not damage the van. Simply slides along the awning rail on the roof of your awning. Once in place you lock the bracket so it never moves after that. 100% Compatibility with Quest Elite Kensington Plus, Windsor Plus and Snowdon awnings.</p>
1041503	<p>Quest Elite Storm Strap Kit Case Pack 5</p> <p>A set of 2 storm strap kits for your awning. They simply click onto the storm strap connection on your awning and allow you to strap your awning to the ground. The large high quality storm spring allows some movement during very strong winds which avoids excess wear and tear on your awning and helps avoid damage. The large metal storm anchor allows you to drive the storm kit well into the ground to create a very strong anchor point for your storm kit.</p>
1041504	<p>Quest Elite Pegging Bands Case Pack 5</p> <p>Set of 10 elastic pegging bands. High quality, very strong plastic. Easy to attach to the awning and gives you 6 different pegging positions. Easy replaced when required. Easily removed and washed if required. 100% Compatibility with Quest Elite Kensington Plus, Windsor Plus and Snowdon awnings.</p>
1041505	<p>Quest Elite Red Plastic Pegs Case Pack 5</p> <p>Set of 10 high quality plastic pegs. These are larger and stronger than traditional metal pegs. They are easy to drive into the ground and hold better than traditional metal pegs. The highly visible colour makes them easier to see when removing them. Dual hook on the top of the peg to make extraction easy. Ideal for use with any tent, awning or any item that needs pegging into the ground.</p>
1041506	<p>Quest Metal Pegs Case Pack 5</p> <p>Set of 10 metal pegs. Ideal for use with tents, or mud walls for awnings.</p>
1041507	<p>Quest Elite Pole Feet Case Pack 5</p> <p>Set of 2 feet for awning or tent poles. These help stop your pole from sinking into the ground and moving around. They have an extra pegging point which enables you to peg the foot to the ground, thus giving you an anchored position for your pole. Fits any 22mm pole. 100% compatibility with Quest Elite Kensington Plus, Windsor Plus and Snowdon awnings.</p>
1041508	<p>Quest Elite Easy Lock Guy Lines Case Pack 5</p> <p>Set of 2 easy lock guy lines. These are very high quality guy lines with the unique easy lock system on them. These are much easier to use than traditional guy lines due to the unique easy lock system. Simply pull the guy line tight and lock the guy line into the easy lock clamp.</p>
1041509	<p>Quest Elite Curtain Clips Case Pack 5</p> <p>Set of 10 replacement curtain clips for the Quest Elite Kensington Plus, Windsor Plus and Snowdon porch awnings. 100% Compatibility with Quest Elite Kensington Plus, Windsor Plus, Rolli and Snowdon awnings.</p>
1041510	<p>Quest Black Awning Bag Case Pack 5</p> <p>A high quality replacement awning bag for your awning. Can fit a variety of awnings and has 100% compatibility with the Quest Elite Kensington Plus, Windsor Plus and Snowdon awnings, it features a full length zip, dual handles and a Velcro strap that allows the handles to be held together. Size: 100 x 30 x 30 cm.</p>
1041511	<p>Quest Single Wheel Arch Cover Case Pack 5</p> <p>Premium quality, single wheel arch cover. Made from the same high quality heavy duty PVC that the Quest Elite Kensington Plus, Windsor Plus and Snowdon. Dark blue in colour, made to match the Quest Elite Kensington Plus, Windsor Plus, Rolli and Snowdon colours so you can be sure of 100% compatibility with your awning. It comes complete with both awning rail and press stud attachment options (the press studs require the included bases to be screwed onto your caravan) to allow easy attachment to your caravan.</p>
1041512	<p>Quest Double Wheel Arch Cover Case Pack 5</p> <p>Premium quality, double wheel arch cover. Made from the same high quality heavy duty PVC that the Quest Elite Kensington Plus, Windsor Plus and Snowdon. Dark blue in colour, made to match the Quest Elite Kensington Plus, Windsor Plus, Rolli and Snowdon colours so you can be sure of 100% compatibility with your awning. It comes complete with both awning rail and press stud attachment options (the press studs require the included bases to be screwed onto your caravan) to allow easy attachment to your caravan.</p>
1041513	<p>Quest Elite Storm Strap Male Coupler Case Pack 5</p> <p>Set of 2 male couplers for a storm kit. These are replacements for the male coupler on the storm strap attached to your awning. 100% Compatibility with Quest Elite Kensington Plus, Windsor plus and Snowdon awnings.</p>

Cat No Description

Awning and Porch Replacement Parts (Continued)

1041514 Quest Draft Skirt Materials **Case Pack 5**
 This is a large 50m roll of draft skirt material in the same premium quality heavy duty PVC that is used in the draft skirts that come with the Quest Elite Kensington Plus, Windsor Plus and Snowdon awnings. Dark blue in colour. 100% Compatibility with the Quest Elite Kensington Plus, Windsor Plus and Snowdon awnings. It features awning rail along the top and an eyelet every 60cm along the bottom.

1041515 Quest Elite Non-Slip Fixing Clamp **Case Pack 5**
 Set of 2 non-slip fixing clamps. These fixing clamps have a non-slip rubber coated end and come complete with fixing screw and wing nut for easy fix and tightening. The rubber coated ends ensure that poles aren't marked and that the pole does not slip once tightened. 100% Compatibility with Quest Elite Kensington Plus, Windsor Plus, Rolli and Snowdon awnings.

1041516 Quest Elite Black Cowl Cover for Pole Spike **Case Pack 5**
 Set of 3 black cowl covers for awning spikes. These covers slip over the top of the spikes in your awning poles and slide down to your awning. This helps ensure that no water runs down the spike and into your awning. 100% Compatibility with Quest Elite Kensington Plus, Windsor Plus, Rolli and Snowdon awnings.

Replacement Air Tubes, Bladders and Covers

A0018 Replacement Airtube PU Bladder for Easy Air 390 Porch Awning **Case Pack 2**
 A high quality, original parts replacement for the PU Bladder from an Easy Air 390 awning.

A0019 Replacement Airtube PE Cover for Easy Air 390 Porch Awning **Case Pack 2**
 A high quality, original parts replacement for the PE Cover from an Easy Air 390 awning.

A0020 Replacement Airtube PU Bladder for Easy Air 280 Porch Awning **Case Pack 2**
 A high quality, original parts replacement for the PU Bladder from an Easy Air 280 awning.

A0021 Replacement Airtube PE Cover for Easy Air 280 Porch Awning **Case Pack 2**
 A high quality, original parts replacement for the PE Cover from an Easy Air 280 awning.

A0022 Replacement Airtube PU Bladder for Easy Air 350 Porch Awning **Case Pack 2**
 A high quality, original parts replacement for the PU Bladder from an Easy Air 350 awning.

A0023 Replacement Airtube PE Cover for Easy Air 350 Porch Awning **Case Pack 2**
 A high quality, original parts replacement for the PE Cover from an Easy Air 350 awning.

A0025 Replacement Airtube PU Bladder for Easy Air 310 Motorhome Awning **Case Pack 2**
 A high quality, original parts replacement for the PU Bladder from an Easy Air 310 Motorhome awning.

A0026 Replacement Airtube PE Cover for Easy Air 310 Motorhome Awning **Case Pack 2**
 A high quality, original parts replacement for the PE Cover from an Easy Air 310 Motorhome awning.

A0028 Replacement Airtube PU Bladder for Easy Air 510 Motorhome Awning and Family Tent **Case Pack 2**
 A high quality, original parts replacement for the PU Bladder from an Easy Air 510 Motorhome awning and family tent.

A0029 Replacement Airtube PE Cover for Easy Air 510 Motorhome Awning and Family Tent **Case Pack 2**
 A high quality, original parts replacement for the PE Cover from an Easy Air 510 Motorhome awning and family tent.

CARRIAGE

Orders in excess of the amount listed below will be carriage free. All orders under this amount will attract a carriage surcharge. Any area's not covered by the list below will be arranged individually.

- Mainland UK : £250.00
- Northern Ireland : £500.00*
- Northern Ireland : £500.00*
- Channel Islands : £500.00*
- Isle of Man: £500.00*
- Scottish Highlands: £500.00

*Carriage to Northern Ireland, EIRE, Channel Islands and the Isle of Man may incur an additional freight cost based on the order value and the freight charges at the time of order.

RECEIVING GOODS

Please ensure that you and your staff sign the carriers consignment notes for the correct number of boxes actually received. Any discrepancies must be notified of immediately. There can be no claim for shortage of boxes signed for.

SETTLEMENT

All accounts are due for settlement 30 days from the date of invoice.

OVERDUE ACCOUNTS

An interest charge of 2% per calendar month will be applied to all overdue accounts. Legal fees and expenses of recovery will be recharged to the customers.

RETURNS

Carriage charges for goods returned to us via your own carrier are non-redeemable without prior authorisation. Goods returned should be notified under separate cover stating invoice number and reason for return.

NOTE: Only complete items in new condition will be replaced or credited to your account and no cheque or cash refunds will be issued.

DESCRIPTIONS

All details and sizes are approximate and for guidance only.

PRICES

All prices are subject to alteration without prior notice.

RETENTION OF TITLE

The property on all items sold by the company shall remain with the company until such sums at any time owing to the company under this or any other contract have been paid in full. The company reserves the right to repossess the items at any time and from any person, firm or company and from any place until such sums due to the company have been paid in full.

...outdoor leisure, home & garden



Fir Tree House, Claybrook Drive, Washford Ind Est, Redditch, Worcestershire B98 0DT

Tel: 01527 516 518 **Fax:** 01527 516 519 **Email:** info@questleisure.com

Web: www.questleisure.com