

TABLE OF CONTENTS

- SECTION 1 INTRODUCTION

- SECTION 2 SYSTEM CONFIGURATION FOR CARD SET NO. 67119
 - 2.1 CARD SET
 - 2.2 BACK PLANE

- SECTION 3 3-D FRAME CONFIGURATION
 - 3.1 FRAME COMPONENTS
 - X-Y Monitor
 - System Enclosure
 - Rear Panel
 - Cooling Fan
 - Power Supplies
 - Card Cage
 - Front Panel Control

- SECTION 4 SYSTEM OPERATION
 - 4.1 3-D MANIPULATION
 - Analog Presentation
 - Applications
 - 4.2 OPERATION USING VIDEO INPUT
 - Video Input
 - System Initialization
 - Rotation
 - Zoom
 - Translation
 - X1-Size
 - Crop and Slice
 - Perspective
 - 4.3 OPERATION USING 3-VECTOR INPUT

TABLE OF CONTENTS (CONTINUED)

- SECTION 5 CARD FUNCTIONS AND SCHEMATICS
- 5.1 VIDEO TO ANALOG CONVERTER CARD
 Card Model No. 66080A
 - 5.2 INPUT INTERFACE CARD
 Card Model No. 66911
 - 5.3 CROP/SLICE AND ZOOM CARD
 Card Model No. 66034
 - 5.4 BASIC 3-D SYSTEM CARD
 Card Model No. 66014

 - 5.5 3-D VIDEO OUTPUT CARD
 Card Model No. 66082A
 X1 Size
 Line Drivers
 Blanking and Contrast
 Perspective and Shading
 Card Schematics
 - 5.6 IMAGE ROTATOR CARD
 Card Model No. 66025

SECTION 1

INTRODUCTION

The Three-Dimension Image manipulator is a high speed real time image processing system which will allow a standard video image to be displayed in three axes. The system may also be used to view three independent axes of data in real time. There are various configurations of the system available; however, the principle system consists of a 3-D frame, model 67118, and a set of cards to produce the image manipulation, model 67119.

The 3-D frame consists of all controls, X-Y monitor, power supplies and a wired back plane.

The 67119 card set includes the following card:

<u>MODEL</u>	<u>QUANTITY</u>	<u>NAME</u>
66080	1 each	Video to Analog Converter
66911	1 each	Input Interface
66034	1 each	Crop/Slice and Zoom
66014	1 each	Basic 3-D System Card
66082	1 each	3-D Video Output Card
66025	3 each	Image Rotator Card

All controls are located on the front panel with the exception of the rear panel mounted ON/OFF switch and the INPUT SELECT switch which selects either the VIDEO INPUT (Switch Out) or the three axes input; X1, X2 and X3. All input line connectors are BNC and located on the rear panel. The video input line is terminated with a 75 resistor; the other input lines have high impedance inputs.

The manual is divided into five sections. The card set and 3-D Frame are handled separately since the configuration is determined by the application and may change from unit to unit. For this reason they are sold separately. The card set number and 3-D Frame number refer to specific configurations. This approach allows the end user to configure the system to meet their requirements.

Section 2 is the Card Set Configuration followed by the 3-D Frame Configuration, Section 3. System Operation is covered in Section 4, and the functions and card schematics are reviewed in Section 5.

SECTION 2

SYSTEM CONFIGURATION FOR CARD SET NO. 67119

SECTION 2.1 CARD SET

System Card Set No. 67119 is designed to implement a 3-Dimensional manipulator, along with a high speed X-Y monitor. The system is configured to provide most of the available manipulation functions. The specific functions are:

1. Video (RS-170) to analog conversion
2. Non-video vector input
3. Zoom (magnification)
4. Translation
5. Crop and slice
6. Shading and perspective
7. Rotation

The X-Y monitor is used to display graphical information in real time. The input to the system may be either a video signal in the RS-170 (NTSC) format or three input voltages that are to be displayed as a correlated function. The video input should be terminated with a 75 resistor at the 44 pin edge connector.

The recommended system block diagram is shown in Figure 2.1.1 The card set consists of eight cards:

- | | |
|------------------------------|--------|
| 1. Video to Analog Converter | 66080 |
| 2. Input Interface | 66911 |
| 3. Crop/Slice and Zoom | 66034 |
| 4. Basic 3-D System Card | 66014 |
| 5. 3-D Video Output Card | 66082A |
| 6. Image Rotator (3 each) | 66025 |

The cards are supplied with the appropriate modules and auxiliary components.

The composite Video to Analog Converter transforms composite (RS-170) video into three corresponding voltages, along with a blanking output pulse as shown in Figure 2.1.2. The output signals are the inverted video line information (neg. video out), horizontal ramp out, and vertical ramp out. These three signals are subsequently processed as X1, X2, and X3, respectively.

The Input Interface Card, No. 66911, provides several functions. First, the card provides the high frequency analog switches for changing the system inputs from video to vector (X1, X2 and X3) information.

Secondly, the card provides buffer amplifiers for the control voltages used in the Crop and Slice, and Zoom functions.

The analog information that is to be processed by the rest of the system is designated as X1, X2 and X3 outputs from the 66911 card.

The Zoom/Crop and Slice, Card No. 66034, provides three functions:

1. Zoom: The zoom function controls the image magnification using the same magnification factor on all three axes.
2. Crop: The crop function operates along the X2 and X3 axes and allows the operator to remove regions of the image that are not of critical interest in order to concentrate on a specific region of the image. Four control voltages to the card are used to Crop: Left, Right, Top and Bottom. The control circuit on the card also acts to translate the remaining region to the center of the display. The purpose of the controlled translation is to keep the area of interest in the center of the screen, otherwise zoom and rotation could move it from the field of view.
3. Slice: The Slice function allows information along the Z (or X1) axis to be blanked from view depending on the level of the control voltage. Positive slice displays only the information less than the slice level and negative slice displays information above the slice level. If both positive and negative slice are used in conjunction with the Slice Width Control, the displayed image will be a slice through the Z-axis (X1) information. The width of the slice will depend on the magnitude of the Slice Width control voltage.

The card set has three Image Rotators, Card No. 66025; the rotators allow the displayed image to be independently rotated about any of the three axes.

The 3-D System card, 66014, converts the three axes of information into the quasi 3-D image on the X-Y monitor.

The Output Amplifier Card, 66082A, contains the drive amplifiers for the X-Y monitor, along with the Blanking Generator which modulates the beam current, the Z axis, of the monitor. The blanking generator cuts the beam off during the timing periods of vertical and horizontal sync, as well as during the Crop and Slice functions.

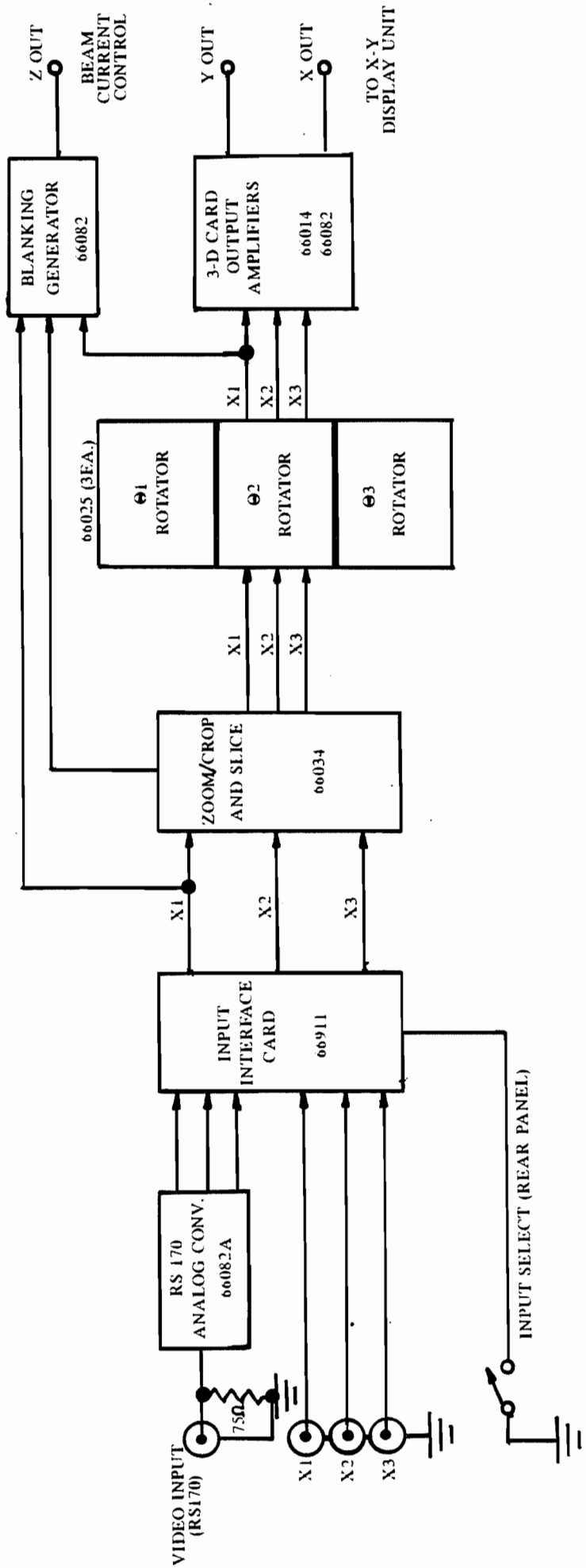

FIGURE 2.1.1 SYSTEM BLOCK DIAGRAM FOR CARD SET NO. 67119

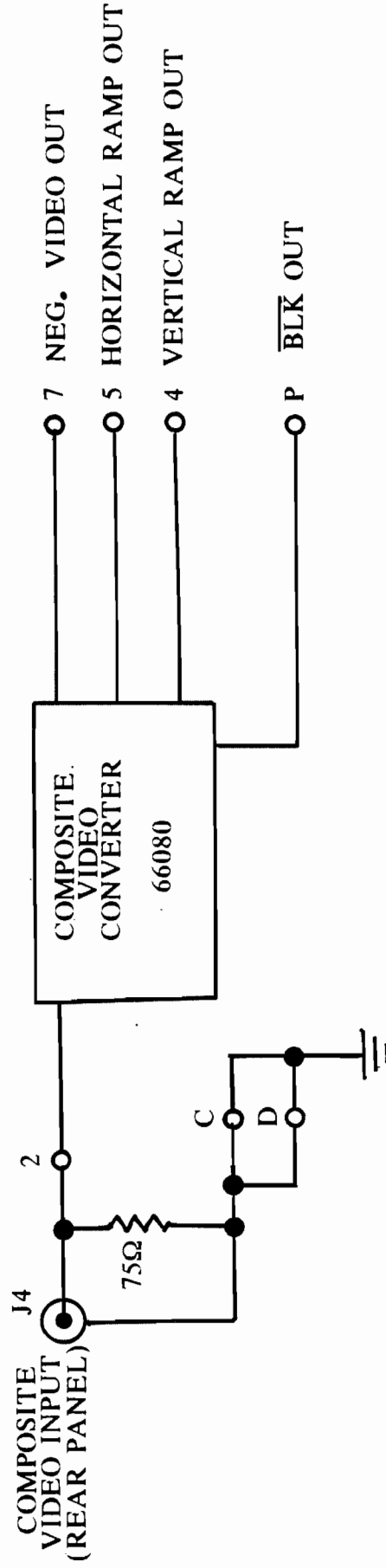

FIGURE 2.1.2 SIGNAL FLOW CONFIGURATION FOR THE 66080 COMPOSITE VIDEO TO ANALOG CONVERTER CARD.

SECTION 2.2 BACK PLANE

The interconnection of the cards is done on the Back Plane of the Card Cage. Eight 44-pin edge connectors are required for the 67118 card set. Figure 2.2.1 shows the card sequence.

The complete card interconnection schematic is given in Figure 2.2.2.

The edge connector pin numbers are given just outside of the card block diagram. The card numbers are given within the card blocks.

The lines designated with "FP" go to the Front Panel of the complete system for the generation of the various control voltages.

The signal flow diagram is given in Figure 2.2.3. The schematic gives the internal functions for each card in the 67118 card set. The schematic diagram should be used in conjunction with each card description given in Section 5.

The control voltages are set using potentiometers and the reference voltages, i.e. +10.00V. The wiring schematic for the control potentiometers used with the 67118 card set is given in Figure 2.2.4. The only high frequency signals are on the "Contrast" control potentiometer.

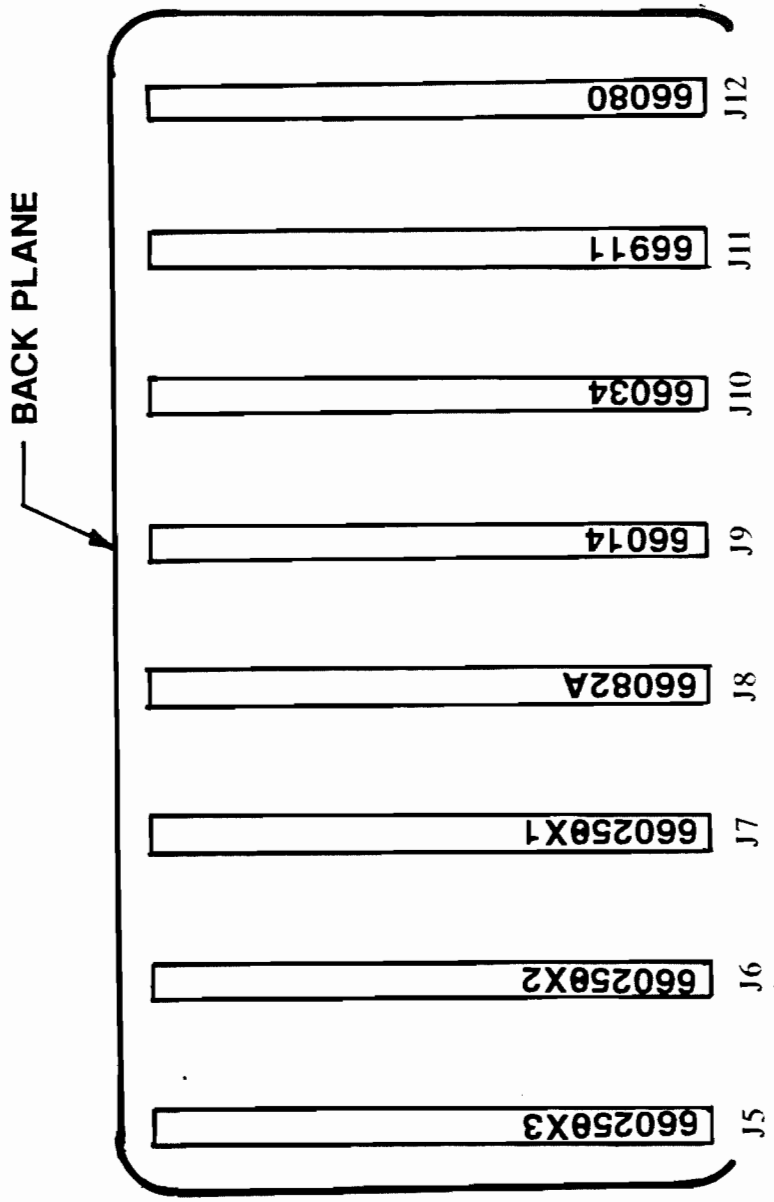
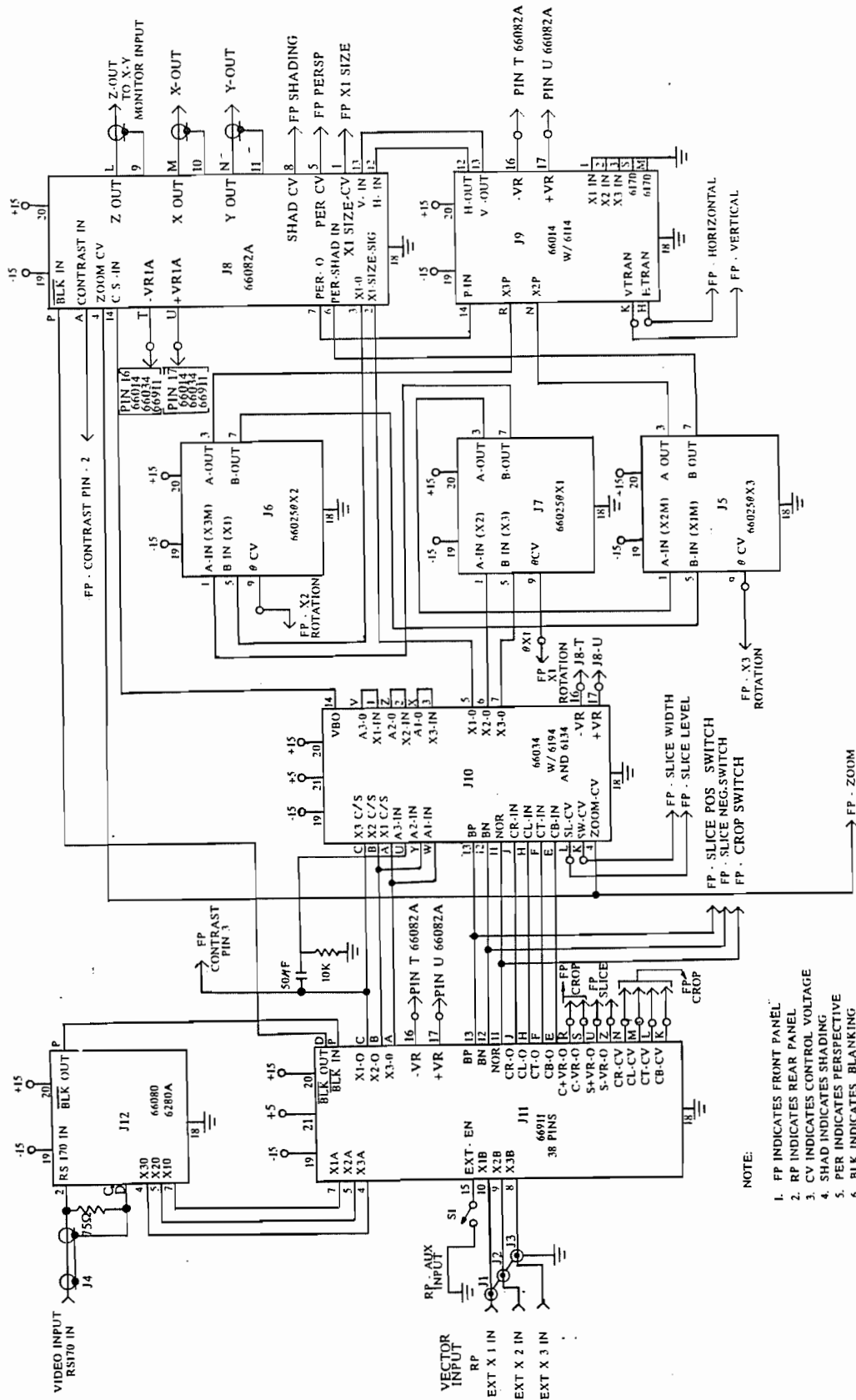

FIGURE 2.2.1 TOP VIEW OF CARD CAGE WITH CARD LOCATION



NOTE:

1. FP INDICATES FRONT PANEL
2. RP INDICATES REAR PANEL
3. CV INDICATES CONTROL VOLTAGE
4. SHAD INDICATES SHADING
5. PER INDICATES PERSPECTIVE
6. BLK INDICATES BLANKING

FIGURE 2.2.2 CARD INTERCONNECTION SCHEMATIC FOR CARD SET NO. 67118

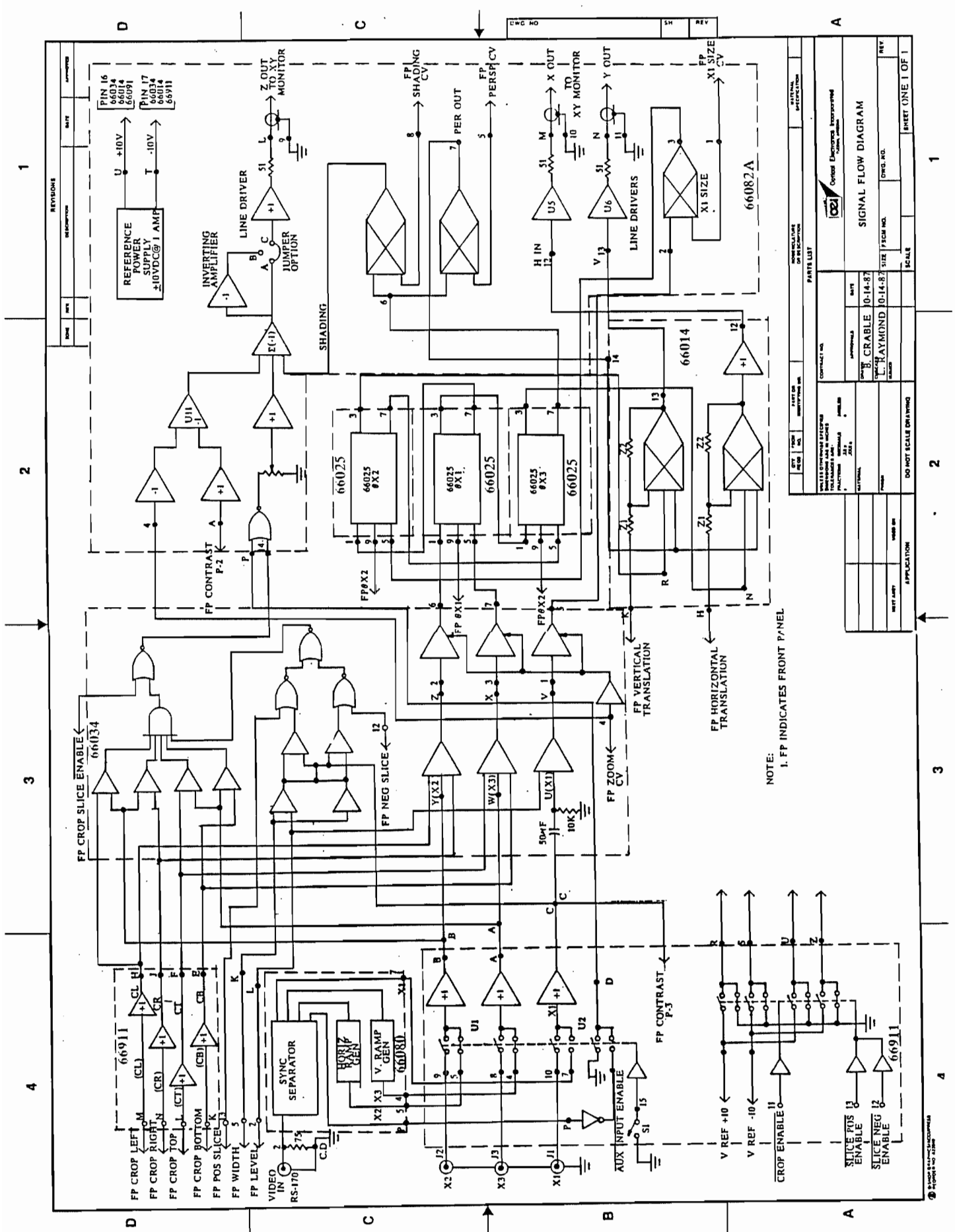

FIGURE 2.2.3 SIGNAL FLOW DIAGRAM FOR 3-D MANIPULATOR

REVISIONS		DATE		APPROVED	
NO.	REV.	DATE	BY	DATE	BY

PARTS LIST		NOMENCLATURE OR DESCRIPTION		QUANTITY	

CONTRACT NO.		DATE		REV.	
DESIGNER		DRAWN		CHECKED	
PROJECT		SCALE		SHEET ONE OF 1	

SECTION 3

3-D FRAME CONFIGURATION MODEL NO. 67119

The 3-D Frame is designed to provide the major subsystems needed to support a 3-D display system. The card selection is sold separately since there are a number of card configurations which are application specific.

The 3-D frame contains the following:

1. X-Y monitor
2. System enclosure
3. Rear panel BNC input connectors and input selection switch
4. Cooling fan
5. Power Supplies
 - (a.) +15VDC @ 0.8A
 - (b.) +5VDC @ 1.0A
6. Card cage with backplane connectors
7. Front panel controls

SECTION 3.1 FRAME COMPONENTS

X-Y Monitor

Data Check monitor, Model No. 5010, is a high speed X-Y monitor with electrostatic deflection. The vertical and horizontal amplifiers have a frequency response of 5MHZ. The Z axis amplifier, which is used to modulate the beam intensity, has a frequency response of DC to 7.5MHZ. The operations manual is supplied with the 3-D Frame, Model No. 67119.

The enclosure is supplied by Data Check in order to provide an integrated system appearance. The monitor as shown in the manual has been slightly modified to incorporate it into the 3-D system.

The monitor comes with three BNC connectors on the rear of the monitor that serve as the X, Y and Z inputs to the monitor. These three connectors have been removed to avoid inadvertent damage to the monitor. The X, Y and Z input lines are internally terminated with 51 resistors and coaxial lines are installed from the monitor to the backplane of the card cage. This modification is an option from Data Check and does not modify the system warranty.

The direct monitor controls are located on the front panel just to the right of the monitor screen. The controls are:

1. Intensity
2. Focus
3. Horizontal
4. Vertical

A complete description of the monitor is provided in the Data Check manual.

System Enclosure

The system enclosure is supplied by the monitor manufacture and will fit in a standard 19" rack. The 3-D frames are normally shipped as stand alone instruments; however, rack mounting flanges may be ordered from OEI or Data Check, Corporation. If the 3-D system is to be rack mounted, it is strongly suggested that additional side supports, such as slide rails, be installed to carry the weight of the system.

Rear Panel

The system inputs are all located on the rear panel to provide clear access to the controls on the front panel. Four (4) data input lines with BNC connectors are provided on the rear panel.

The "Video Input" is designed to be used as the RS-170 (NTSC) video input line. The BNC connector is provided with an internal 75 line which goes from the input connector (J4) to the backplane, and it is terminated with a 75 resistor.

The 3-D system may also be operated using three input vectors (voltages) in the form of X1, X2 and X3. The input lines are connected to their respective BNC input connectors, J1, J2 and J3.

The "INPUT SELECT" switch allows the operator to select either the "Video Input" or "X1, X2 and X3" inputs. When the switch is "out", the video input is selected, and conversely, when the switch is depressed, the three vector inputs, X1, X2 and X3, are selected.

The schematic diagram for the input connectors is shown in Figure 3.1. The power cord is also located on the rear panel along with the ON/OFF Switch.

Cooling Fan

A three inch axial cooling fan is mounted on the inside of the rear panel. It is low noise and has a very low EMI output. The card cage and power supplies are mounted to allow for maximum free flow of air. The top cover is inserted with the air vent holes to the front of the system.

Power Supplies

The power supplies for the X-Y monitor are an integral part of the monitor and are hence covered in the manual for the monitor.

The power distribution schematic for the 67119 is given in Figure 3.1.2. Both fuses, F1 and F2, are internal to the enclosure and the cover must be removed to change the fuses.

Fuse, F2, provides protection for the 3-D system power supplies and fan.

The 3-D system, Model 67119, requires three voltages for operation:

- +15 VDC @ 1.5 Amp.
- 15 VDC @ 1.5 Amp.
- + 5 VDC @ 1.2 Amp.

The power supplies are manufactured by Condor, Incorporated, 2311 Slathaw Parkway, Oxnard, California 93033. A dual power supply, Condor P.N.:BB15-1.5, is used to supply both +15VDC @ 1.5 Amp. and -15VDC @ 1.5 Amp.

The output lines are shown in Figure 3.1.2. The power is carried to the backplane through the Red (+15VDC) and Black (-15VDC) lines; the supplies have "sense lines" that control the voltage at the backplane terminals. The backplane voltages are returned to +S (red) and to -S (black) located on the power supply. The ground line is handled in a similar manner.

The +5VDC @ 1.2 Amp. is supplied from a Condor, Model No. A5-1.2/OVP power supply. The system connections for the +5VDC supply are shown in Figure 3.1.2.

All power supplies are wired for 120 VAC operation. For line voltages other than 120 VAC consult OEI for correct system modifications.

Card Cage

The Card Cage supplied with the 3-D Frame is designed to hold up to eight 4 1/2" x 6 1/2" circuit cards with 44 pin edge connectors. The frame also includes the 44 pin jack connectors for connecting the cards to the backplane wiring. The wiring and card selection may vary depending on the system application. The card cage is mounted with the backplane toward the front panel to minimize the length of control lines from the front panel and to provide efficient air flow around the cards.

Specific wiring of the card cage is covered in a separate section relating to the system configuration.

Front Panel Controls

The electronic modules available for use in the 3-D systems use control voltages as input parameters. Reference voltages of +10.00VDC and -10.00VDC are used to generate the control voltages through potentiometers mounted on the front panel. This approach minimizes the use of high frequency signals on the front panels where the signals could be rapidly degraded by stray signals and coupling capacitances.

The potentiometers that are generally used have concentric shafts to increase the number of possible control functions on the front panel.

The exact layout and configuration is given in a separate section on the specific system configuration.

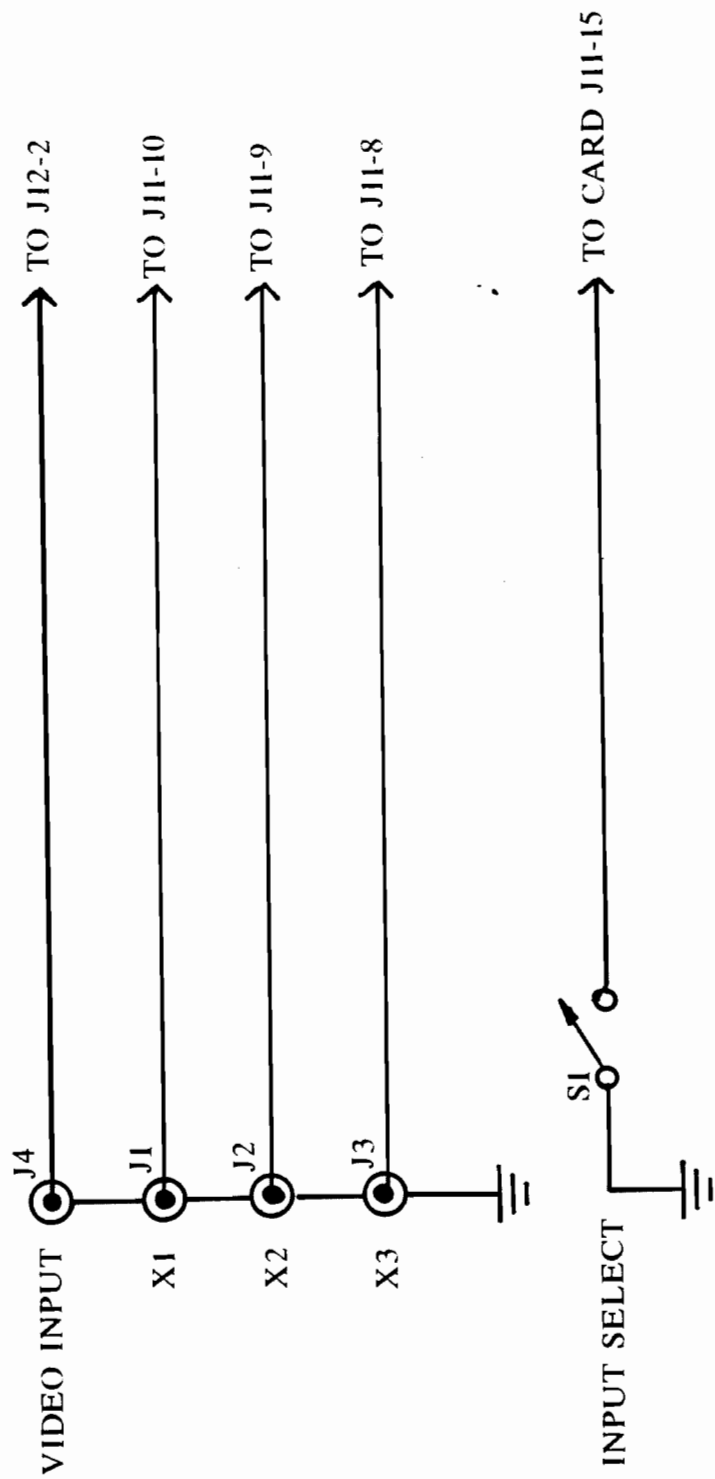
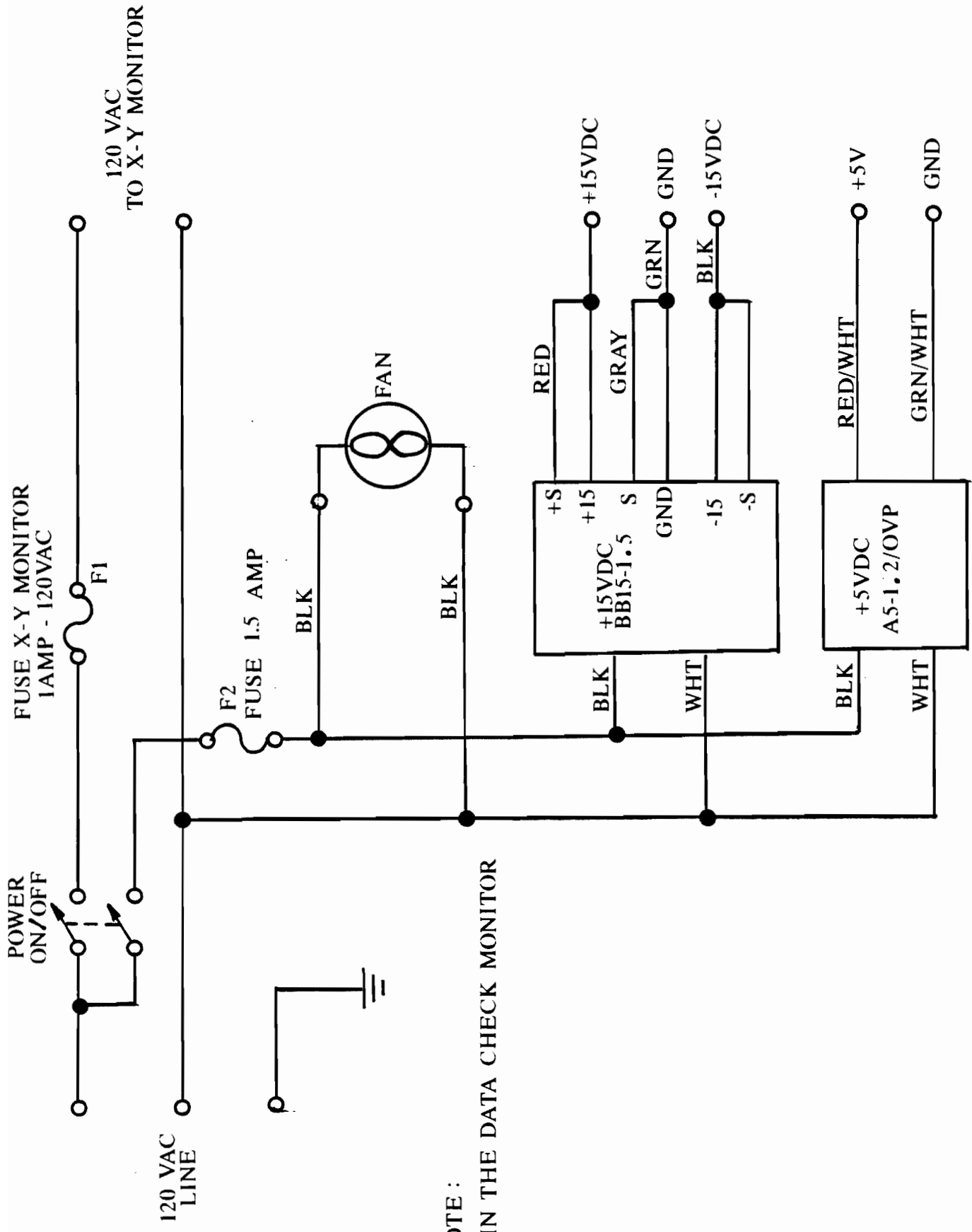

FIGURE 3.1.1 BACK PANEL SIGNAL WIRING 67119



NOTE :
1. F1 IS IN THE DATA CHECK MONITOR

FIGURE 3.1.2 POWER DISTRIBUTION FOR 671119

SECTION 4 SYSTEM OPERATION

SECTION 4.1 3-D MANIPULATION

The goal of presenting visual data is to communicate the relationship the variables have with one another. Two dimensional information can be displayed as a single plot of the two variables; however, three or more simultaneous variables present significant display problems. If the information can be fed into a computer, a three dimension display may be generated using standard graphic display techniques.

Given the requirement that the data are very high speed, video, or that it is necessary to view the data from various orientations, the problem then becomes more difficult with the necessity for greatly increased processing speed. Many applications also require the data to be modified by edge enhancement, gray level detection, filtering, smoothing, or classification.

Digital signal processing is often the approach used. Information generated from a video camera can be digitized and stored by using a frame grabber and frame buffer storage. The digitized data can then be processed directly by the computer or by special image processing boards that will handle the rates required for real time image processing. The processed image may be presented in a variety of ways which might include edge enhancement, false color, histograms, or ratioed. General software is available for image processing; however, specific software for a given application would have to be generated by the system user or designer.

Video images or high speed data may also be processed in the analog mode or combined into a hybrid system using both analog and digital techniques.

System bandwidth is a major design concern in an analog system in order to prevent degradation of the information. Analog processing can be accomplished using high speed multipliers, summing amplifiers, and complex function modules. A high speed X-Y monitor with a 5MHz bandwidth is used for displaying the information. The generation of software is not required to view or manipulate a three axis image. No storage is required.

Analog Presentation

Data collection using video cameras is definitely increasing in the areas of automation, inspection, and identification. In many applications, digital signal processing can be fully utilized; however, there are many applications that require a human to provide the pattern recognition or to make a value judgment about the image that falls outside the realm of digital processing. It is in these application areas that analog processing can be utilized.

A monochromatic video signal is the result of four components: vertical and horizontal axis, gray level, and time. Initially, let us assume the camera is fixed on a single object so that we can neglect time as a variable.

The horizontal and vertical scans give a spacial map of the area viewed by the camera, but there is no information about the object without the gray level information. The three variables taken together present a map of the light intensity measured at the imaging surface.

A standard monitor uses the gray level information to modulate the CRT's beam intensity. Horizontal and vertical scans provide X and Y data and the gray level is interpreted as the third axis, or Z axis data. With real time information, it is quite difficult to make a quick value judgment as to whether one area is more gray than another, and by how much. Pattern recognition is also very difficult if there is a very narrow range of gray levels. Digital signal processing may very well lose part of the needed information if the digitizing steps are large in comparison to the gray level variations.

In the analog processing mode, the three axes of information are processed so that the vertical and horizontal signal present the X-Y information and the gray level is used to deflect the CRT's beam in the Z direction. This is illustrated in Figure 4.1.1.

The deflection of the beam in the Z direction is directly proportional to the gray level. The resulting display contains all of the original information from the scanned object.

All signal levels and display orientation may be modified by the system operator. Using the system's controls, it is possible to magnify the change in gray level so that the details of the object are more recognizable.

The basic system diagram in Figure 4.1.2 gives the configuration used for video signal processing and three-vector information. The input module locks onto the incoming video signal, RS-170, and produces horizontal and vertical ramp voltages along with the gray level signal which has been stripped off the synchronization pulses. Analog processing combines these signals into the desired display.

The same configuration can accept the information in the form of three non-video inputs: X1, X2 and X3. The display will be a direct plot of the three variables.

By using high speed analog processing, the displayed image may be manipulated in a number of ways in order to enhance the input data for analysis. A system can be designed with all or part of the following controls depending on the requirements of the application.

1. Rotation
2. Magnification
3. Zoom
4. Translation
5. Crop and Slice
6. Shading and Perspective
7. Stereo Viewing

The functions may be controlled manually from front panel potentiometers, or the control voltages may be derived from a computer, transducer, or input control.

The image may be independently rotated about all three axes.

Zoom control expands or reduces the image by the same amount on each axis. Translation simply moves the image position on the X-Y display.

Cropping allows a small section of the display to be selectively displayed. The selected section can be rotated and magnified to fill the screen.

Slicing allows limits to be placed on the gray level so that only the region which lies within the limits will be displayed; the rest of the image is blanked.

Shading of the image can be added to provide perspective to the image.

Applications

Image enhancement of a video signal is achieved by modifying the image and by viewing the gray level as a displacement of the beam.

Motion is also enhanced since the human eye can easily detect the movement of the displaced image where it cannot readily see motion in a nearly uniform gray region on a standard display monitor.

With proper surface lighting, defects in parts can be readily detected by enhancing the video image. The resulting three axes display reduces operator fatigue and minimizes the chance of overlooking a defect.

Information generated by non-video sources can also be displayed in the same manner.

Geometrical images generated by computer can be modified and rotated in space without the need for high speed graphics and software.

Additional applications include medical imaging and astronomy.

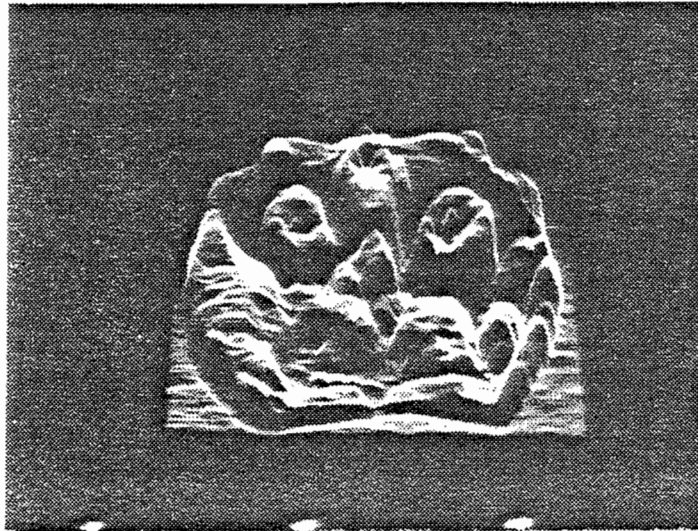

FIGURE 4.1.1 Three axes of information are processed so that the vertical and horizontal signal present the X-Y information and the gray level is used to deflect the CRT's beam in the Z direction.

TABLE 4.1
INITIAL CONTROL SETTINGS

1. Power OFF
2. X-Y monitor controls
 - a) Intensity CCW-FULL
 - b) Focus Mid-point
 - c) Position
 - 1) Horizontal Mid-point
 - 2) Vertical Mid-point
3. Front panel 3-D manipulator controls

<u>CONTROL</u>	<u>POSITION</u>
CROP/SLICE	DOWN
SLICE POSITIVE	DOWN
SLICE NEGATIVE	DOWN
X1 ROTATION	CCW-FULL (0 ROTATION)
X2 ROTATION	CCW-FULL (0 ROTATION)
X3 ROTATION	CCW-FULL (0 ROTATION)
ZOOM	Mid-point (12:00 0'clock)
VERTICAL TRANSLATION	Mid-point (12:00 0'clock)
HORIZONTAL TRANSLATION	Mid-point (12:00 0'clock)
PERSPECTIVE	CCW-FULL
X1 - SIZE	CCW-FULL
CROP LEFT	CCW-FULL
CROP RIGHT	CCW-FULL
CROP TOP	CCW-FULL
CROP BOTTOM	CCW-FULL
SLICE WIDTH	CCW-FULL
SLICE LEVEL	CCW-FULL
CONTRAST	Mid-point (12:00 0'clock)
SHADING	Mid-point (12:00 0'clock)

4. Rear panel controls

INPUT SELECT	OUT
--------------	-----

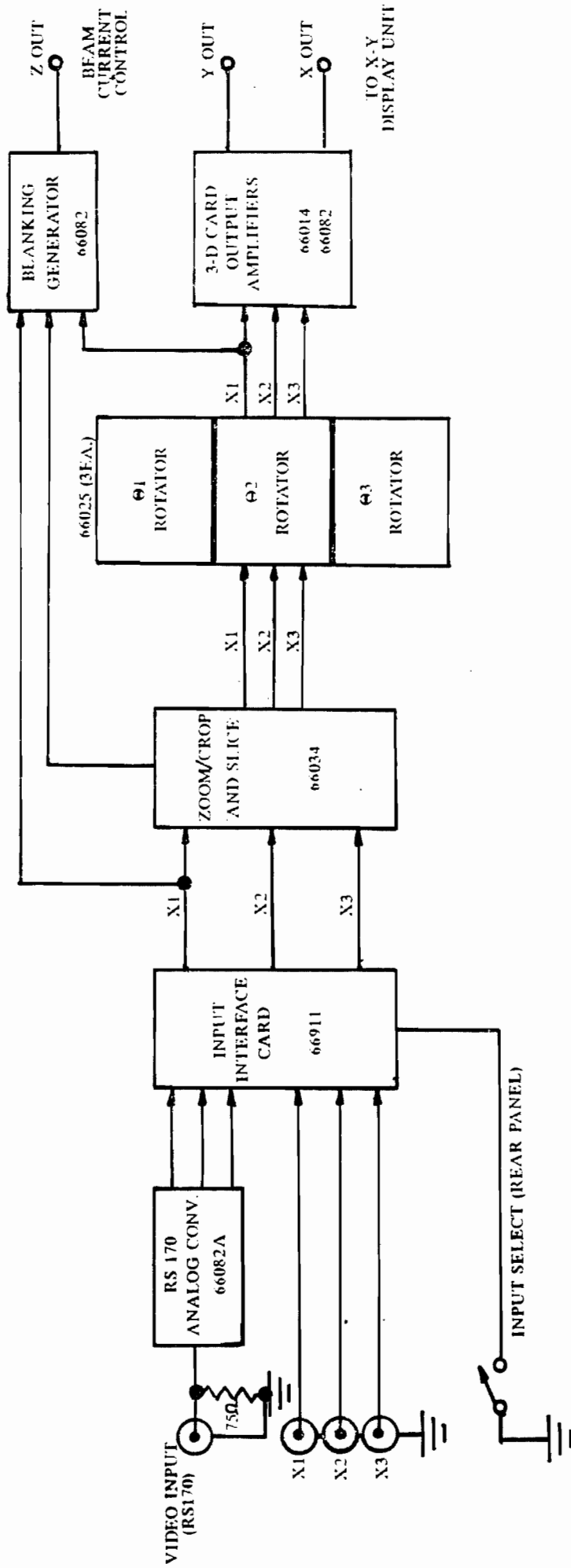

FIGURE 4.1.2 SYSTEM BLOCK DIAGRAM FOR CARD SET NO. 67119

SECTION 4.2

OPERATION USING VIDEO INPUT

The set up and operation of the 3-D manipulator system is generally straight forward; however, it is possible to become confused with all of the input controls when first starting to use the system. System input may be from either a video signal in the RS-170 (NTSC) format or three input vector voltages X1, X2 and X3. All inputs are on the rear panel. Next to the BNC input connectors is the "INPUT SELECT" switch. When the switch button is in the "out" position, the BNC connector designated "VIDEO INPUT" is selected. Pushing the button on the switch to the "in" position disconnects VIDEO INPUT and at the same time connects the vector voltage inputs, X1, X2 and X3, to the system.

The use of the VIDEO INPUT will be reviewed first, followed by a discussion of how to use the vector inputs.

Video Input

First and foremost - DO NOT TURN POWER ON - until the initial control positions have been set on the front panel. It is possible to burn the face of the CRT with a high beam current. The system has internal circuits to limit the beam current to avoid damage, but if the controls are first initialized, it can prevent a possible set of conditions that could result in damage to the CRT face. The electronics and controls will not be damaged by any combination of control settings.

System Initialization

To initialize the 3-D manipulator, follow the control settings given in Table 4.1. DO NOT TURN POWER ON before you have set the controls.

After the controls have been initialized connect a video input from a camera to the rear BNC connector marked VIDEO INPUT. (Format: RS-170)

TURN POWER ON. No image should be seen on the X-Y monitor. (Note: The video input is internally terminated with a 75 resistor; if a standard video monitor or other equipment is connected in series in the video line, make sure that the line is not also terminated in the ancillary equipment.)

Increase the X-Y monitor INTENSITY control (clockwise-rotation) until the raster scan is just visible. Keep the intensity very low, i.e. very dim. Rotate "Contrast" clockwise to approximately mid-range. Then rotate "Shading" clockwise to approximately mid-range. The video image should now be visible to the operator. CONTRAST and SHADING can now be varied to see their respective image response.

Adjust the Vertical and Horizontal POSITION controls on the X-Y monitor to center the image within the area of the monitor face.

The video image should now be visible and appear in the same manner as on a video monitor.

Rotation

There are three axes of rotation; if X1 Rotation control is moved, the image will be rotated around the X1 axis, i.e. the axis which is normal to the screen. Each rotation control has 360 degrees of rotation. When the rotation is counterclockwise-full, the image rotation is 0; when rotated clockwise, the rotation angle increases to 360 degrees.

Using the three ROTATION controls, rotate each control separately in a clockwise direction and then back to full counterclockwise. This will demonstrate the result of each control on the image.

Next try a combination of rotation controls to see the total effect on the image.

Return all ROTATION controls to their full counterclockwise positions.

Zoom

Rotate the ZOOM control from its midpoint position. The image should get smaller with counterclockwise rotation and larger with clockwise rotation.

Return the ZOOM control to its midpoint.

Translation

The 3-D manipulator also has Vertical and Horizontal translation controls in addition to the position controls on the X-Y monitor. Both sets can be used; however, by setting the Position Controls on the X-Y monitor to their midpoints, the translation controls on the 3-D manipulator can then be used for the full range of translation. (Note: When the Crop and Slice functions are in use, there are internal offset voltages generated to automatically keep the image centered.)

X1-Size

Rotate the image about the X2 axis by turning the X2-ROTATION control to the 9:00 O'clock position. The image will rotate 90 and appear as a single horizontal line on the monitor. Rotate X1-SIZE clockwise. The line will expand due to the amplification of the X1 information. The X1 axis corresponds to the gray level amplitude of the video image.

Rotate the image using the X2-ROTATION control. The other two axes may now be rotated to see the visual effects. The ZOOM control may also be used to change the image size.

Crop And Slice

Return controls to the positions given in Table 4.1. Set the SHADING control to 9:00 O'clock position, and turn the CROP/SLICE switch on (i.e. Up position).

Rotate the CROP LEFT control clockwise; this will start to crop, or blank, the left side of the image.

Rotating the other three CROP controls, Right, Top and Bottom, will crop the corresponding portion of the image.

As the image is cropped an internal translation voltage is generated to reposition the remaining part of the image to the center of the monitor. The remaining portion of the image may then be processed using the Rotation, Zoom, or X1-Size controls. The image will remain centered.

Rotate the Crop controls fully counterclockwise.

Turn the POSITIVE SLICE switch on, and rotate the image around the X2 axis using X2-ROTATION (9:00 O'clock position). The image should be a single horizontal line. Rotate X1-Size clockwise until the height of the lines is about half the vertical size of the monitor screen. Rotate the SLICE LEVEL clockwise, as the level is changed, more or less of the positive image amplitude will be blanked from the monitor.

Turn the POSITIVE SLICE off and rotate the SLICE LEVEL counterclockwise. Turn the NEGATIVE SLICE on and rotate the SLICE LEVEL clockwise, as the level is changed, more or less of the negative image amplitude will be blanked from the monitor.

Turn both the NEGATIVE and POSITIVE SLICE switches on and rotate the SLICE WIDTH clockwise. A slice of the image will be generated with both positive and negative amplitudes blanked from the monitor.

The lower slice level is determined by SLICE LEVEL and the upper slice level is the sum of the SLICE LEVEL plus SLICE WIDTH. The slice width will remain constant if the slice level is changed.

The image may now be processed using the other functional controls.

If you have trouble with the process controls, return to the initial conditions given in Table 4.1.

Perspective

Set the controls to the initial conditions given in Table 4.1. Rotate the image around the X2 axis using the X2-ROTATION control leaving the image tilted backwards 60°; rotate the PERSPECTIVE control clockwise. The top of the image will become smaller than the bottom giving the impression that the top of the image is farther away from the viewer than the bottom of the image. Rotate both SHADING and CONTRAST and note the visual effects on the image.

All of the controls may now be used in combination. Should there be a problem or confusion about the controls, call OEI and ask for assistance.

SECTION 4.3

OPERATION USING 3-VECTOR INPUT

The 3-D manipulator may be driven by either a video signal input (RS-170) or by three vector voltages, X1, X2 and X3. All inputs are on the rear panel and selection is made via the INPUT SELECT switch on the rear panel. For the vector inputs, the switch must be depressed in.

The voltage range on the three inputs is: +10.00 volts, (max. +15V) and the input resistance is: 1.5M .

Using the vector inputs is very general and allows the operator complete freedom in designing and orienting the display. However, visualizing the resulting image before setting the system up may prove to be difficult for someone trying it for the first time with a new set of variables. The use of several function generators to learn how to generate images may be very helpful. We have included a short description of how various shapes can be generated. This may be helpful in generating meaningful images using the vector inputs.

SECTION 5 CARD FUNCTIONS AND SCHEMATICS

SECTION 5.1

VIDEO TO ANALOG CONVERTER CARD

Card Model No.: 66080A

CIRCUIT DESCRIPTION: The 66080 uses the Model 6280A module to perform a conversion of composite video into the basic components of positive video, negative video, horizontal and vertical sync and blanking pulses, plus vertical and horizontal deflection ramps. Customer optional components can be added to change the 66080 from standard 525 line, 60 frames per second video to other scan rate systems.

The heart of the 66080 card is the 6280A module.

CIRCUIT DESCRIPTION: Model 6280A is a composite video to analog converter designed specifically for use in a 3-D display system to produce isometric video displays. It can be used in other applications for manipulating video in special effects and in computer analysis of video images. The 6280A produces video less sync pulses, horizontal and vertical sync and blanking pulses and horizontal and vertical ramps. It is internally set for a scanning rate of 15.7 kHz horizontal, and 60 Hz vertical. Other rates can be externally set. The 6280A will accept interlaced sync.

The 6280A module pin out diagram is shown in Figure 5.1.1.

The card schematic used in the 3-D system is given in Figure 5.1.2 and the inverting amplifier for the horizontal output is shown in Figure 5.1.3.

Signal flow through the 66080 card is illustrated in Figure 5.1.4. The composite video signal is applied to the card using a 75 coax line; the 75 termination resistor is not on the card, but should be attached on the rear edge connector, J8, between pin 2 and pins C and D. If the input line is terminated elsewhere, this resistor should not be included in the system. Other line impedances may be used by properly terminating the lines.

The video input is processed by the 6280A module. The sync pulses are stripped from the input video signal. The video is then inverted and given as the X1 output on edge connector pin 7.

Additionally, the sync separator generates vertical and horizontal timing pulses which are available at the edge connector on pins N and T, and are used internally to trigger the vertical and horizontal ramp generators. The vertical ramp becomes (X3) and leaves the card on connector pin 4. The horizontal ramp is inverted and becomes (X2) at connector pin 5. The ramp outputs are +10V full scale.

Composite blanking is also generated by the 6280A module, pin 19, and is connected to pin P on the edge connector.

The module and card specifications are given in Tables 5.1.1 and 5.1.2, respectively.

The edge connector pin list is given in Table 5.1.3, and the component layout is given in Figure 5.1.5. The component list is given in Table 5.1.4.

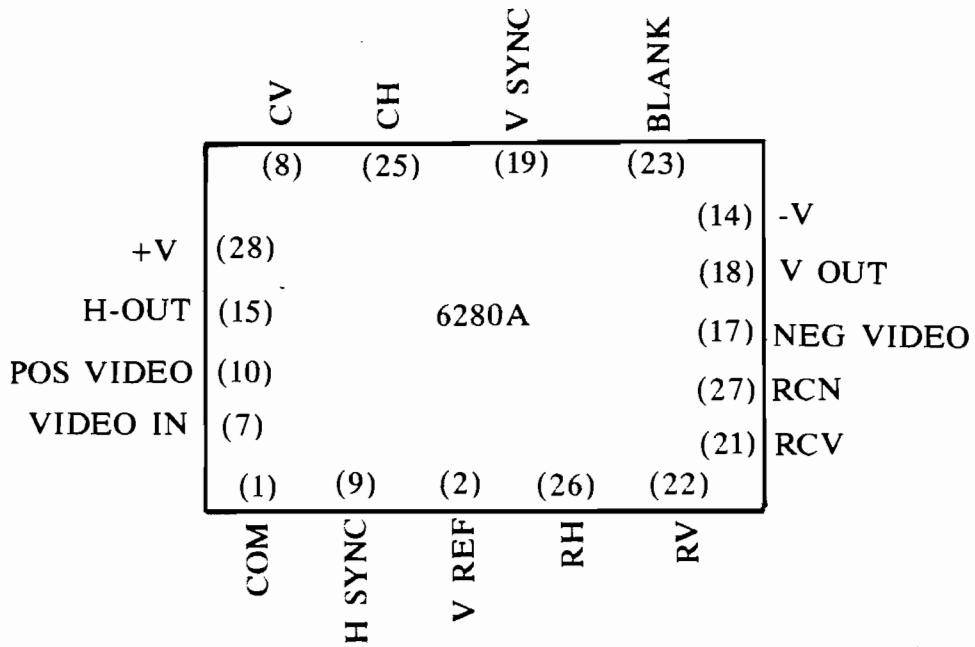

FIGURE 5.1.1 COMPOSITE VIDEO TO ANALOG DISPLAY CONVERTER MODEL NO 6280A

Model 6280A

COMPOSITE VIDEO TO ANALOG DISPLAY CONVERTER

SPECIFICATIONS:¹

Video Input	
Resistance	100 k ohm minimum
Voltage Level	1.4 volts peak-to-peak nominal
Polarity	Positive Video only
Video Output	
Voltage Level	0 to 10 volts full scale
Polarity	Both positive and negative video provided
Ramp Outputs	
Voltage Level	±10 volts full scale
Polarity	Negative going
Sync/Blanking	
Voltage Level	+15 volts "HIGH" +0.1 volt "LOW" nominal
Polarity	Positive pulses
Frequency Response	
Video Bandwidth	1Hz to 3MHz, -3dB points, nominal
Sync Pulse	100ns rise and fall nominal
Temperature Environment	
Operating Range	-55° C to +85° C
Storage Range	-65° C to +100° C
Thermal Resistance of Module	15° C/watt maximum
Quiescent Temperature Rise	23° C above ambient max.
Power Required	
Minimum Voltage	±12 volts
Nominal Rated Voltage	±15 volts
Maximum Voltage	±18 volts
Quiescent Supply Current	±35mA maximum
Quiescent Power Dissipation	1050mW maximum
Size	3.25 inches by 1.5 inch by 0.625 inch high 8.26 cm by 3.81 cm by 1.59 cm high
Weight	4 ounces 114 gm
Socket	OEI Model 11028
MTBF per-MIL-HDBK-217B-GF	261,000 hours

NOTES: 1-The above specifications are measured at ±15 volts supply and +25° C ambient.

CASE STYLE: This is a module having 18 pins.

Pins are Gold Plated per MIL-G-45204, type 2, class 2, 0.040 inch (0.102 cm) in diameter.

Dimensional tolerance is ±0.010 inch (±0.0254 cm).

Material is Glass Fiber filled Diiallyl-Phthalate with filled epoxy encapsulant.

Dimensions are in inches (centimeters).



TABLE 5.1.1

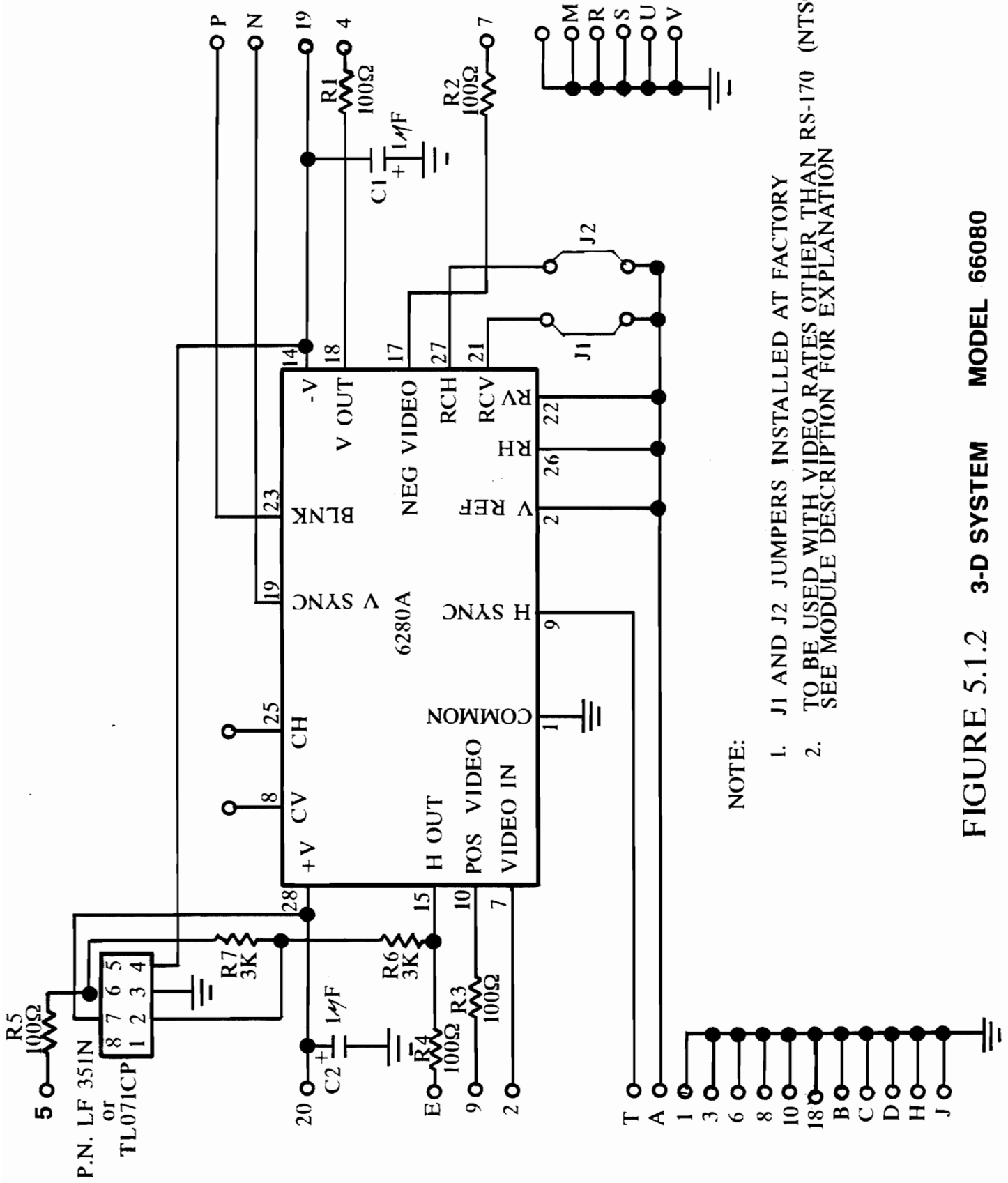

NOTE:

1. J1 AND J2 JUMPERS INSTALLED AT FACTORY
2. TO BE USED WITH VIDEO RATES OTHER THAN RS-170 (NTSC)
SEE MODULE DESCRIPTION FOR EXPLANATION

FIGURE 5.1.2 3-D SYSTEM MODEL 66080

Model 66080

COMPOSITE VIDEO TO ANALOG CONVERTER CARD

SPECIFICATIONS: ¹

The following data does not include the 6280A Module. For more information check the 6280A data sheet.

Temperature Environment	
Operating Range	0° C to +70° C
Storage Range	-55° C to +100° C
Power Required	
Minimum Voltage	±13 volts
Nominal Rated Voltage	±15 volts
Maximum Voltage	±18 volts
Quiescent Supply Current	±3 milliamps maximum
Quiescent Power Dissipation	90 milliwatts maximum
Size	6.5 inches long by 4.5 inches wide. Suitable for mounting on 1.0 inch centers.
Weight	3.5 ounces 100 gm
MTBF-per-MIL-HDBK-217B-GF	1,349,000 hours
Connector	Standard card edge connector two rows of 22 contacts on inch centers for .062 inch thick circuit boards.

NOTES: 1-The above specifications are measured at ±15 volts supply and +25° C ambient.

TABLE 5.1.2

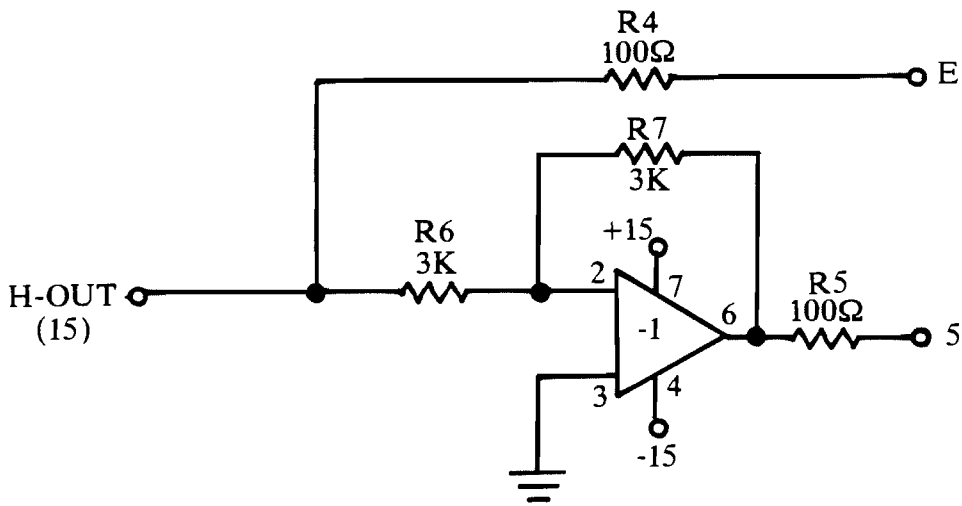

LF 351N
OR
TL 071CP

FIGURE 5.1.3 INVERTER AMPLIFIER FOR H-OUT 66080

TABLE 5.1.3

COMPOSITE VIDEO TO ANALOG CONVERTER CARD

MODEL NO. 66080

EDGE CONNECTOR:

<u>PIN</u>	<u>FUNCTION</u>
20	+15V
19	-15V
18	Common
T	H-Sync Out
P	Blanking-Out
N	V-Sync Out
9	Positive Video Out
7	Negative Video Out
5	Inverted H Ramp Out
E	H Ramp Out
4	V Ramp Out
2	Composite Video In
A	V-Ref. Out

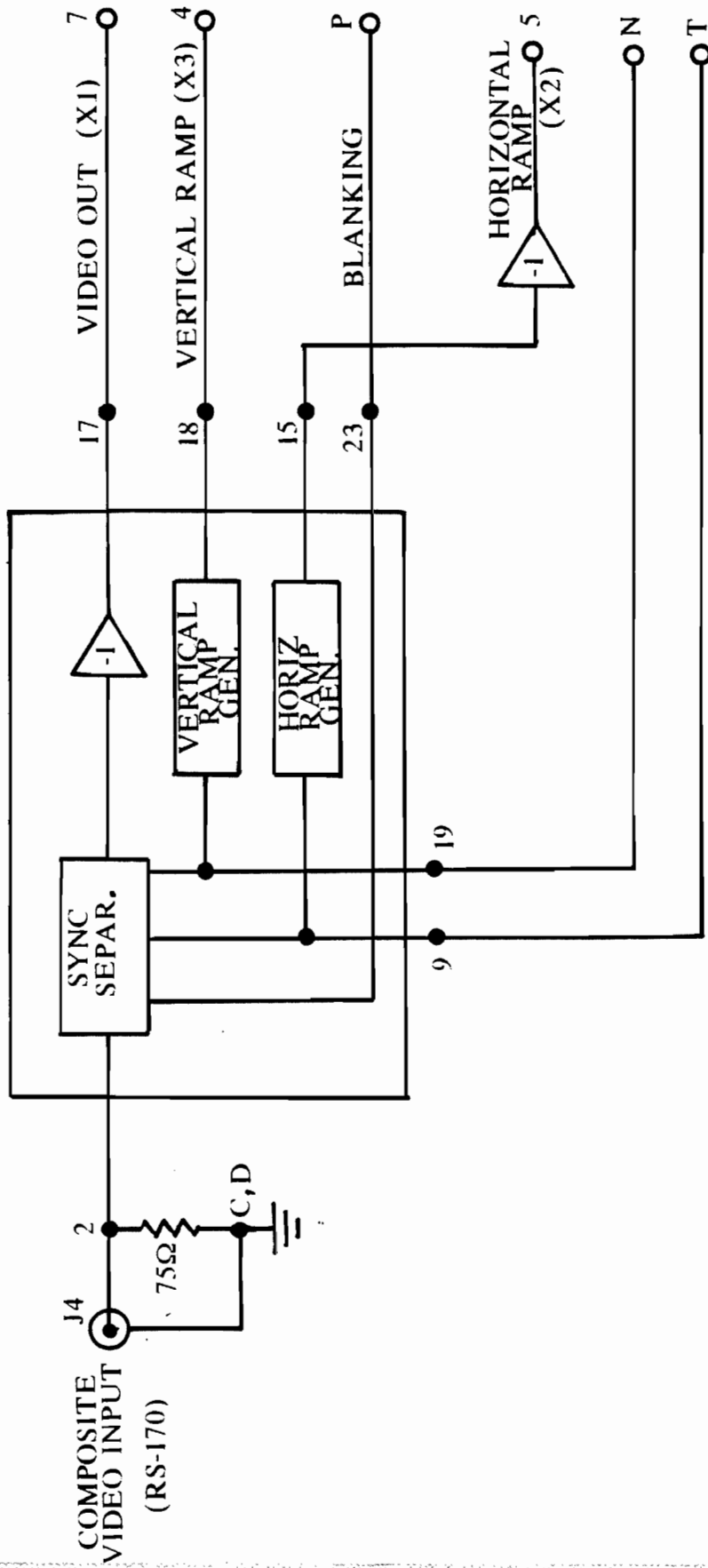

CONFIGURATION IS SHOWN FOR THE 3-D SYSTEM

FIGURE 5.1.4 SIGNAL FLOW CONFIGURATION FOR THE 66080A, VIDEO TO ANALOG CONVERTER CARD.

TABLE 5.1.4

MODEL NO. 66080

DATE 10-9-87

PARTS LIST

QTY	ID#	PART #	DESCRIPTION	MFGR #	MFGR NAME
1	U1	150367	Integrated Circuit	LF351N	National
2	C1,C2	180023	Capacitor 1.0 Micro F		Kermet
5	R1-5		Resistor 100 OHM		
2	R6,7		Resistor 3K		
1			OEI 6280A		OEI

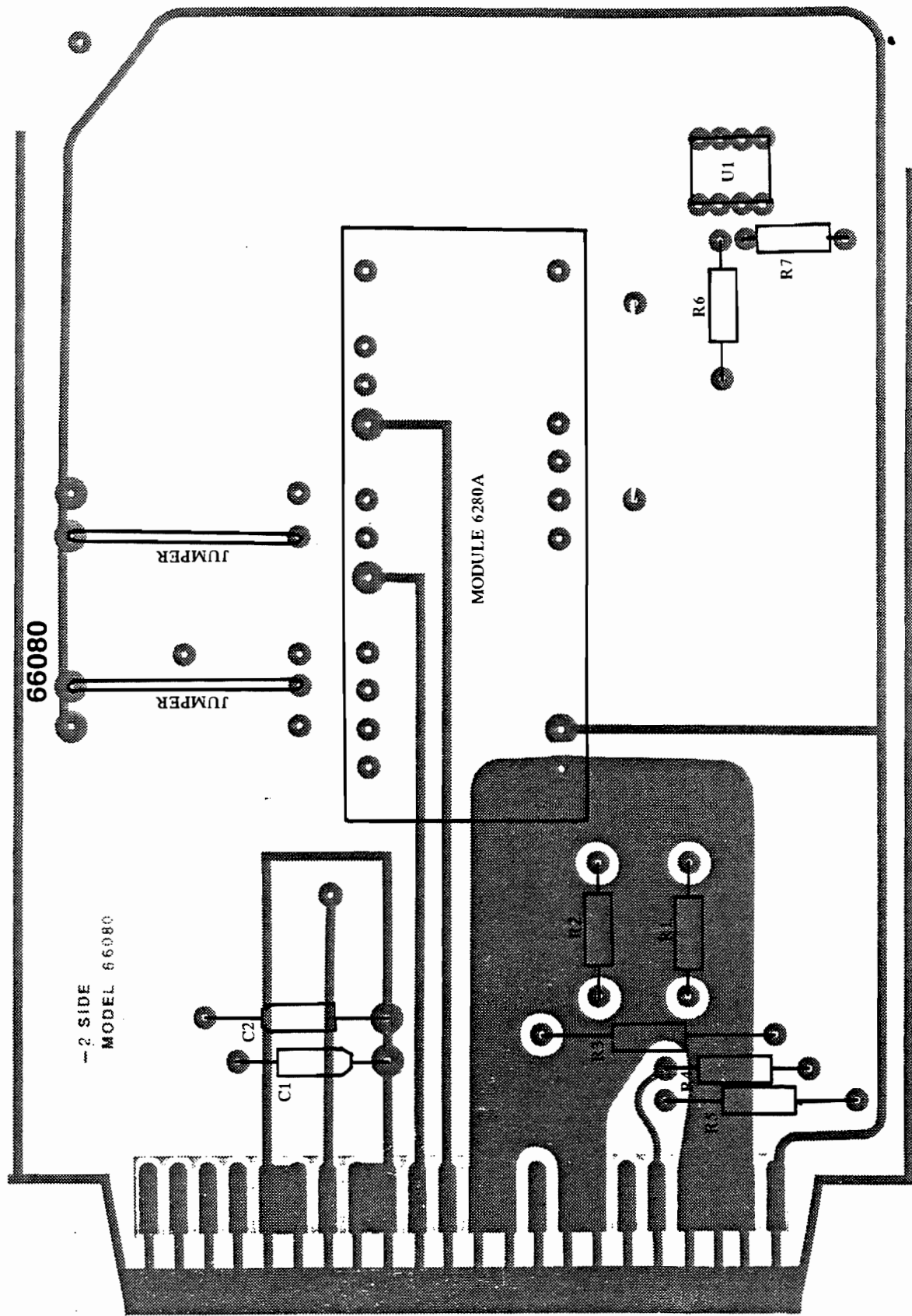

FIGURE 5.1.5 VIDEO TO ANALOG CONVERTER CARD COMPONENT LAYOUT, MODEL 66080

SECTION 5.2

INPUT INTERFACE CARD Card Model No.: 66911

The input interface card provides high frequency switching between the video signals from the video to analog converter card, 66080, and the auxiliary inputs X1, X2 and X3. In addition, the card provides reference voltage switching and input voltage buffer amplifiers for the crop and slice functions on the 66034 card.

The high frequency switching is done with analog switches and helps to maintain the integrity of the input signals. The block diagram for the 66911 is shown in Figure 5.2.1. Analog switches U1 and U2 provide the switching between two sets of input axes:

- Set 1 : Video X1
Video X2
Video X3

- Set 2 : Aux X1
Aux X2
Aux X3.

Set 1 is generally used for the input lines from the video to analog converter, 66080A. The video lines are connected so that X1 corresponds to the video intensity, and X2 and X3 correspond to the horizontal and vertical ramp inputs, respectively. Video blanking is also switched; when the auxiliary inputs are selected, the video blanking output, (D), is switched to ground.

The high frequency lines (X1,X2,X3) are connected to buffer amplifiers which are capable of driving 100mA max. lines.

Analog switches, U3 and U4, apply +10VDC reference voltages to the control potentiometers when the crop and slice functions on the 66034 card are used. The analog switches change state when the corresponding enable lines are held at ground level (11,12,13).

The control voltages for the crop functions are derived from their respective potentiometer and have a voltage range of +10VDC. Amplifiers U5 and U6 are dual buffer amplifiers which drive the control voltage inputs of the 66034, crop and slice card.

The complete card schematic for the Input Interface Card is given in Figure 5.2.2 (3 sheets).

The card layout for the 66911 card is given in Figure 5.2.3, and the parts list is given in Table 5.2.

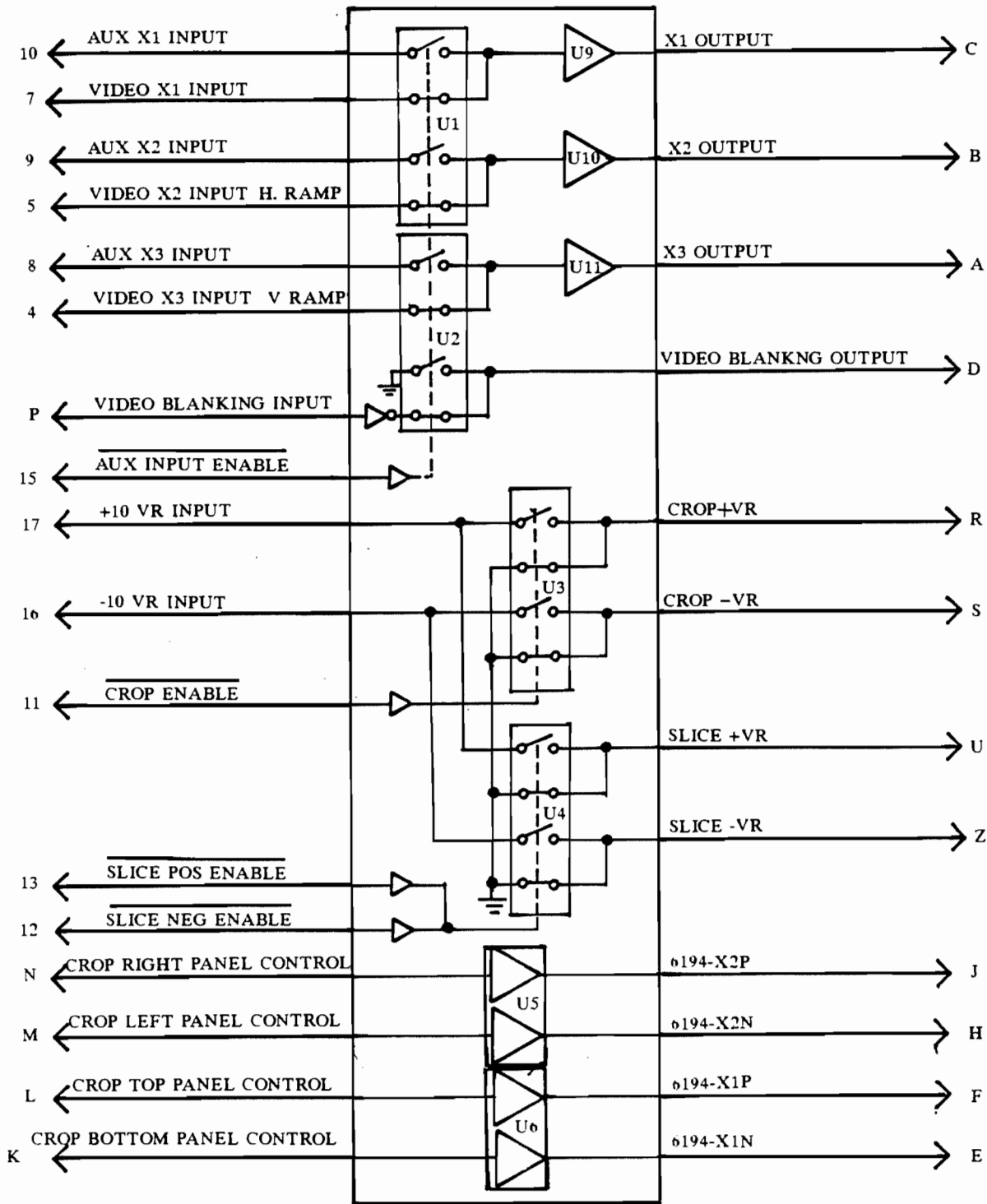

BLOCK DIAGRAM 66911

INPUT INTERFACE CARD BLOCK DIAGRAM , CARD NO, 66911

FIGURE 5.2.1

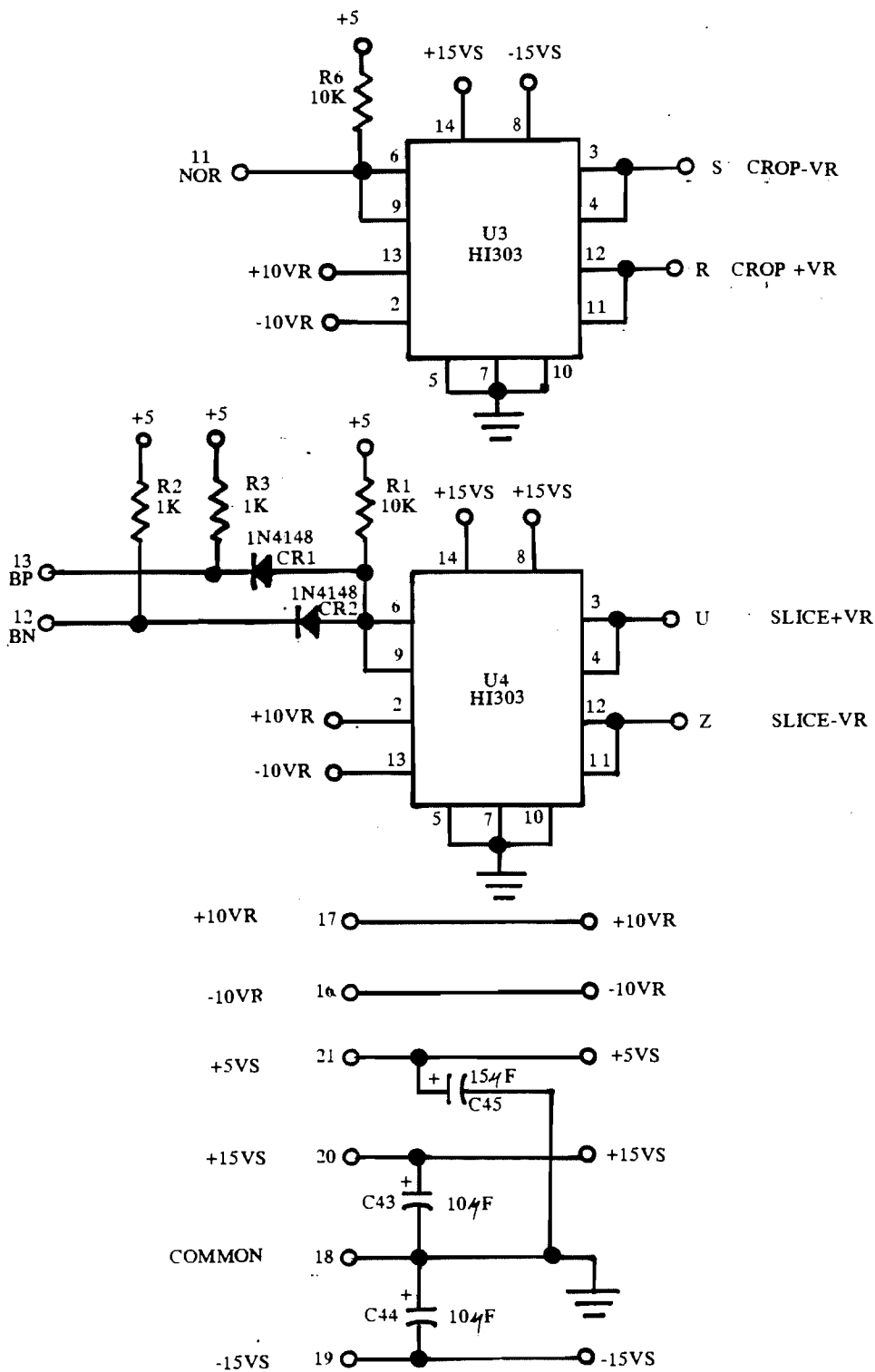

SCHEMATIC 66911

SHEET 1 OF 3

SCHEMATIC DIAGRAMS FOR THE INPUT INTERFACE CARD, MODEL 66911.

FIGURE 5.2.2 a

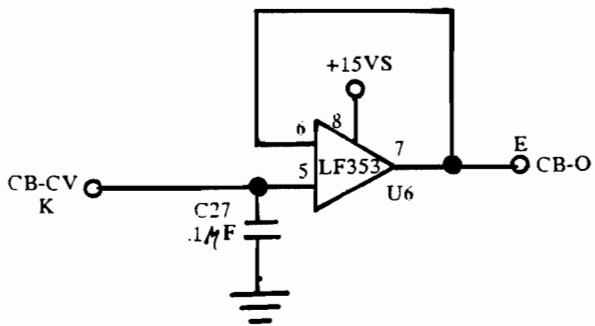
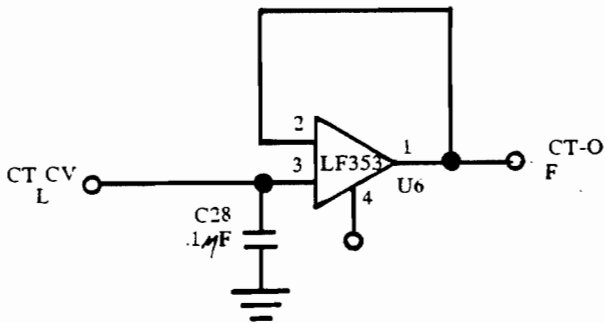
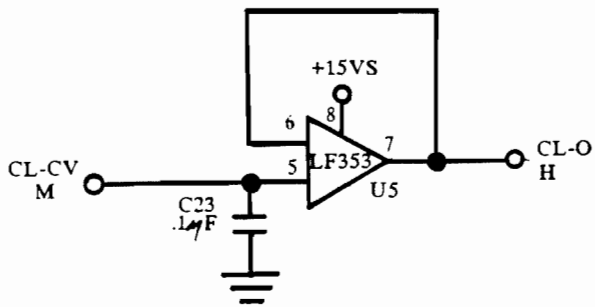
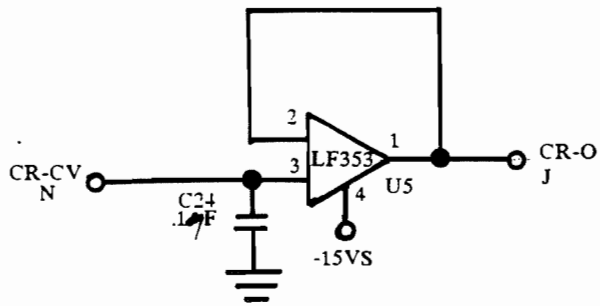

SCHEMATIC 66911

SHEET 2 OF 3

FIGURE 5.2.2b

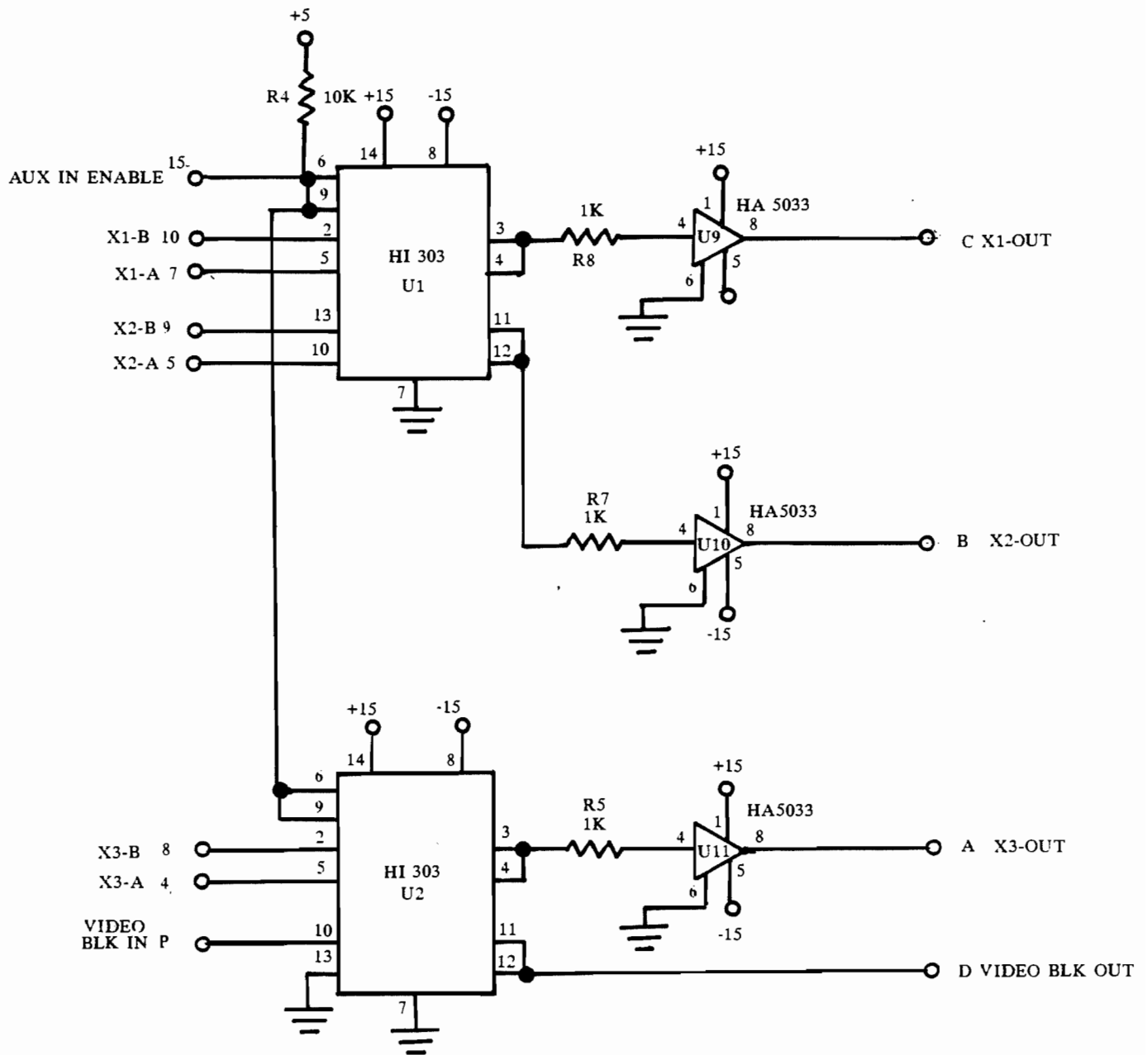

SCHEMATIC 66911

SHEET 3 OF 3

FIGURE 5.2.2c

TABLE 5.2

MODEL NO. 66911DATE 10-9-87PARTS LIST

QTY	ID#	PART #	DESCRIPTION	MFGR #	MFGR NAME
4	U1,2,3,4	150430	I.C. CMOS Analog Sw.	H13-0303-5 #1303	Harris
2	U5,6	150386	I.C. Wide Band Dual	LF353N	National
3	U9,10,11	150440	I.C.	HA3-5033-5	Harris
2	CR1,2	160017	Diode	IN4148	Gen Elec
2	C43,44	180075	Capacitor 10 Micro F		Kemet
1	C45	180024	Capacitor 15 Micro F		Kemet
18	C10-19 C1-8	180023	Capacitor 1.0 Micro F		Kemet
3	R1,4,6		Resistor 10K		
5	R2,3,5, 7,8		Resistor 1K		

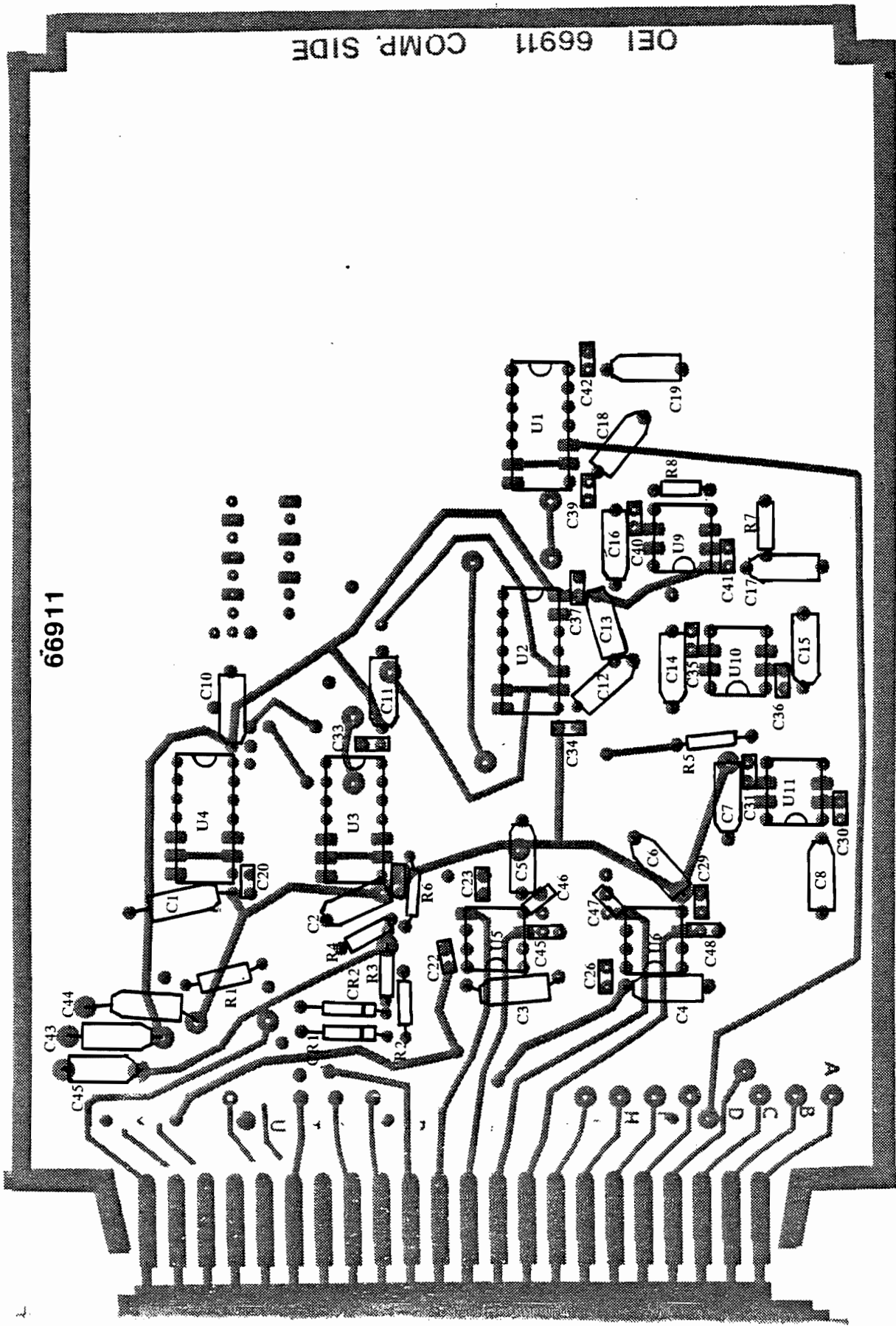

FIGURE 5.2.3 COMPONENT LAYOUT FOR THE 66911 INPUT INTERFACE CARD.

SECTION 5.3

CROP/SLICE AND ZOOM CARD

Card Model No.: 66034

The 66034 card requires two modules for full operation. Module No. 6134 provides image magnification and Module No. 6194 produces the crop and slice functions. Additional circuitry on the card automatically centers the image when the crop and slice functions are in operation.

Module No. 6134, Image Magnifier, provides a convenient method of zooming or magnifying and minifying an image, whether 2-D or 3-D. The image size is directly proportional to the control voltage. The voltage gain of the signal path varies from zero to unity. If the module is combined with a gain of 10 amplifier, the image may be magnified by 10X or reduced down to zero. The input control voltage has a 0.0 to +10VDC range.

The module block diagram is given in Figure 5.3.1. All three input vectors, X1, X2 and X3, are amplified by the same factor. A +10VDC reference is required for proper operation. The module's specifications are given in Table 5.3.1 and the module pin out is given in Figure 5.3.2.

Crop and slice functions are provided by Module No. 6194. The inputs to the 6194 are three vectors, X1, X2 and X3, and control voltages. Figure 5.3.3 illustrates the crop function. The object is to crop, or remove, sections of the image leaving only the desired portion of the image displayed on the X-Y monitor. The 6194 does not modify the X1, X2 and X3 voltages directly, but compares the vector voltages to the control voltages. The resultant output is a blanking signal which blanks the X-Y monitor's beam when the blanking signal is low.

Additional circuitry may be added to the 66034 card which will keep the cropped image in the center of the screen. This is a great advantage if the image is zoomed or rotated. The cropped image will remain in the center when magnified or rotated. The functional block diagram of the crop and slice module is given in Figure 5.3.4.

The slice function generates a blanking signal which is combined with the one from the crop function. The slice function compares the "Slice Level" voltage, applied to card connector pin L, to the vector level, X1. If zero volts is applied to card connector pin 13, a blanking pulse will be generated which will blank the display for all values of X1 greater than "Slice Level". If zero volts is applied to card pin 12, a blanking pulse will be generated which will blank the display for all values of X1 less than "Slice Level".

If zero volts is applied to both card connector pins 12 and 13, a slice through the image is generated. The width of the slice is determined by the voltage level applied on card connector pin K. Once the slice width is set it will remain constant in width and follow the Slice Level through the image.

The card back diagram for the 66034 is shown in Figure 5.3.5, and the card edge connector pin list is given in Table 5.3.2.

Component layout for the 66034 card is given in Figure 5.3.6, and the component part list is given in Table 5.3.3.

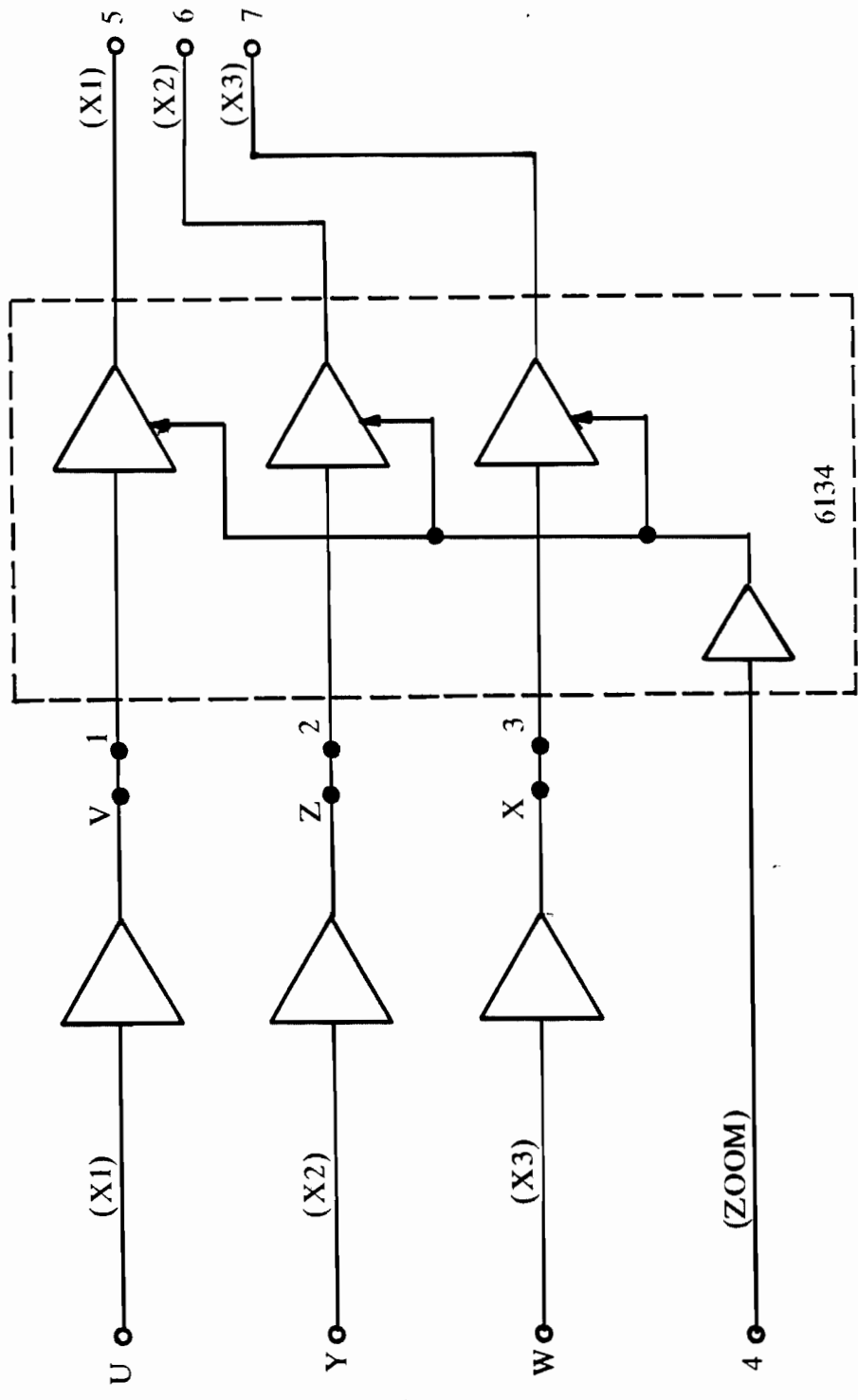

FIGURE 5.3.1 BLOCK DIAGRAM FOR THE 6134 MODULE USED FOR THE ZOOM FUNCTION ON THE 66034 CARD.

Model 6134

IMAGE MAGNIFIER (ZOOM)

SPECIFICATIONS:¹

Magnification Range	0 to 10X
Input	
Signal Level	±10 volts full scale
Resistance	10M ohms nominal
Bias Current	10 μ A maximum
Frequency Response	DC to 500 kHz
Output	
Signal Level	±10 volts full scale
Load Current	±5mA minimum
Control Input	
Voltage Range	0 to +10 volts
Resistance	1.0M ohm minimum
Temperature Environment	
Operating Range	-55° C to +100° C
Storage Range	-65° C to +100° C
Thermal Resistance of Module	13° C/watt maximum
Quiescent Temperature Rise	7° above ambient maximum
Power Required	
Minimum Voltage	±12 volts
Nominal Rated Voltage	±15 volts
Maximum Voltage	±18 volts
Quiescent Supply Current	±18 milliamps maximum
Quiescent Power Dissipation	540 milliwatts maximum
Size	2.00 inch square by 0.4 inch high, 5.08 cm square by 1.02 cm high
Weight	1.8 ounce 51 gm
Socket	OEI Model 11028
MTBF-per-MIL-HDBK-217B-GF	338,000 hours

NOTES: 1-The above specifications are measured at ±15 volts supply and +25° C ambient.

TABLE 5.3.1

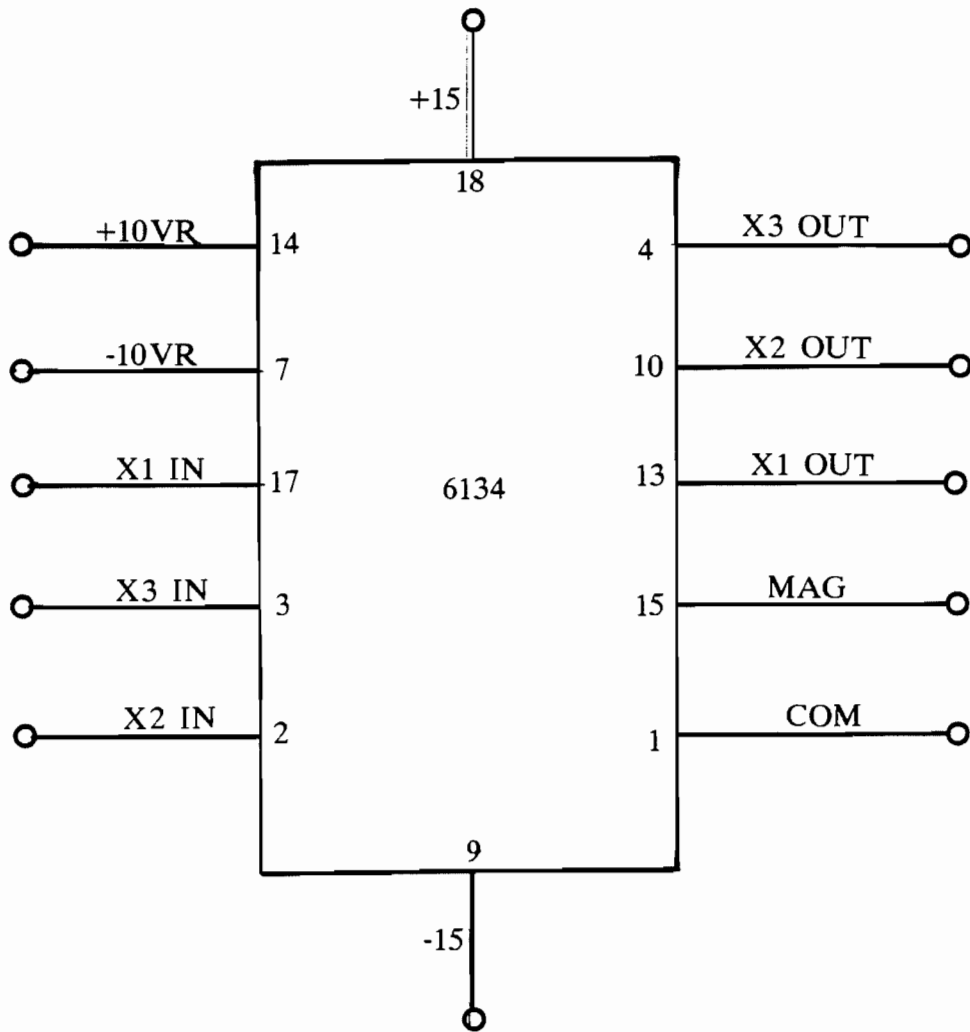

PINOUT FOR MODULE 6134

FIGURE 5.3.2

TABLE 5.3.2

IMAGE ZOOM WITH CROP AND SLICE

EDGE CONNECTOR:

CARD NO. 66034

<u>PIN</u>	<u>FUNCTION</u>
21	+5 Volts
20	+15 Volts
19	-15 Volts
18	Common
17	+ V REF
16	-V REF
15	6194 - VBOC
14	6194 - VBO
13	6194 - BP
12	6194 - BN
11	6194 - NOR
10	6194 - VSOL
9	Stereo - MAG.
8	NC
7	6134 - X3 Out
6	6134 - X2 Out
5	6134 - X1 Out
4	MAGNIFICATION
3	6134 - X3 In
2	6134 - X2 In
1	6134 - X1 In
Z	XZ Out
Y	XZ In
X	X1 Out
W	X1 In
V	X3 Out
U	X3 In
L	6194 - LEVEL
K	6194 - WIDTH
J	6194 - X2P
H	6194 - X2N
F	6194 - XIP
E	6194 - XIN
C	6194 - X30
B	6194 - X20
A	6194 - X10
M	PINS M&S
S	ARE JUMPERED TOGETHER
N	PINS N AND T ARE JUMPERED
T	TOGETHER

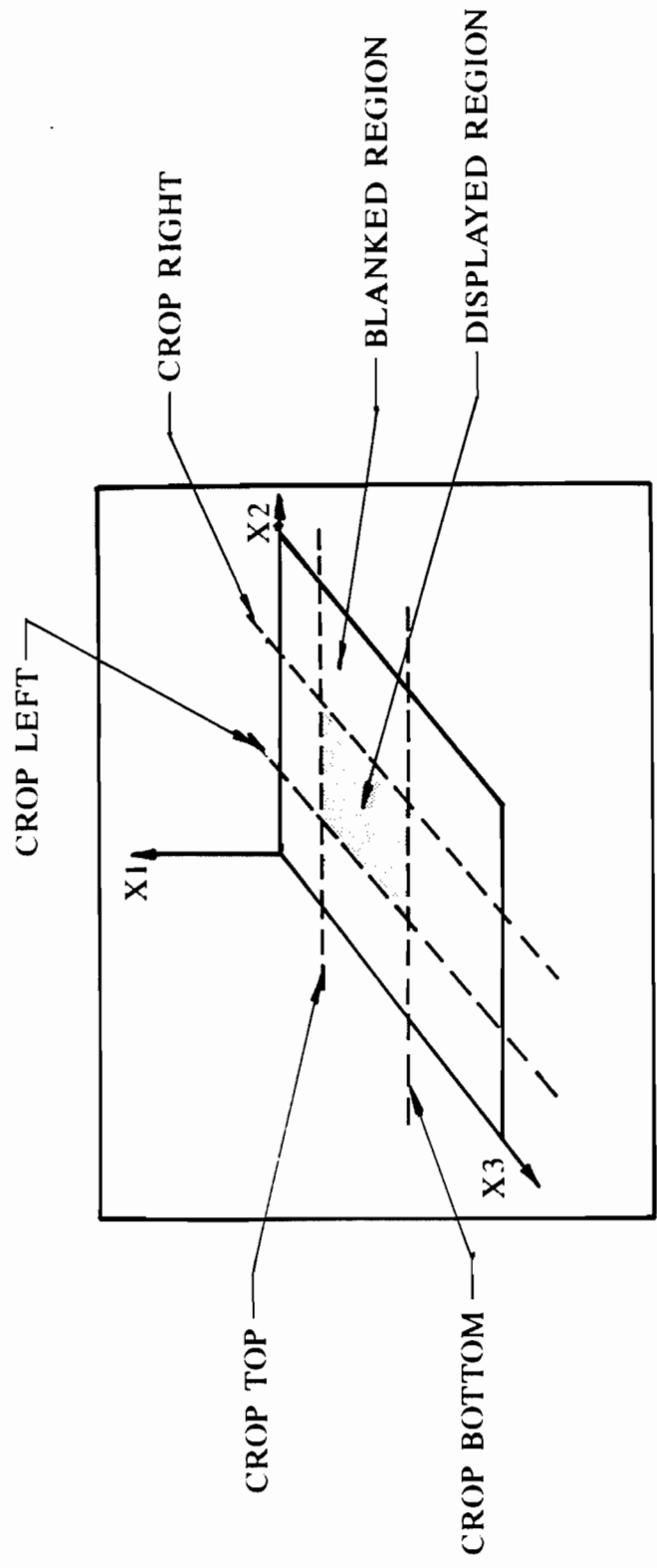

ONLY THE REGION BOUNDED BY THE FOUR CROP LEVEL
 WOULD BE DISPLAYED ON THE X-Y MONITOR.

FIGURE 5.3.3 ILLUSTRATION OF IMAGE CROP FUNCTION

TABLE 5.3.3

MODEL NO. 66034DATE 10-9-87PARTS LIST

QTY	ID #	PART #	DESCRIPTION	MFGR #	MFGR NAME
2	U1,U2	150386	I.C. Wide Band Dual	LF353N	National
3	A2,3,4	150206	I.C. OP Amp/Buffers	LM318H	National
1	A1	150367	I.C.	LF351N	National
3	C1,2,3	180023	Capacitor 1 uF		Kemet
9	R7,8,11,12 13,14,19,20,21		Resistor 3K		
4	R1,2,16,18		Resistor 10K		
2	R15,17		Resistor 20K		
6	R3,4,5,6, 9,10		Resistor 100K		
1	RV1	191633	Resistor, 10K 20T Variable		Allen Bradley
1	Q1	170086	Transistor (N-Channel)	S0 211DE	Signetics

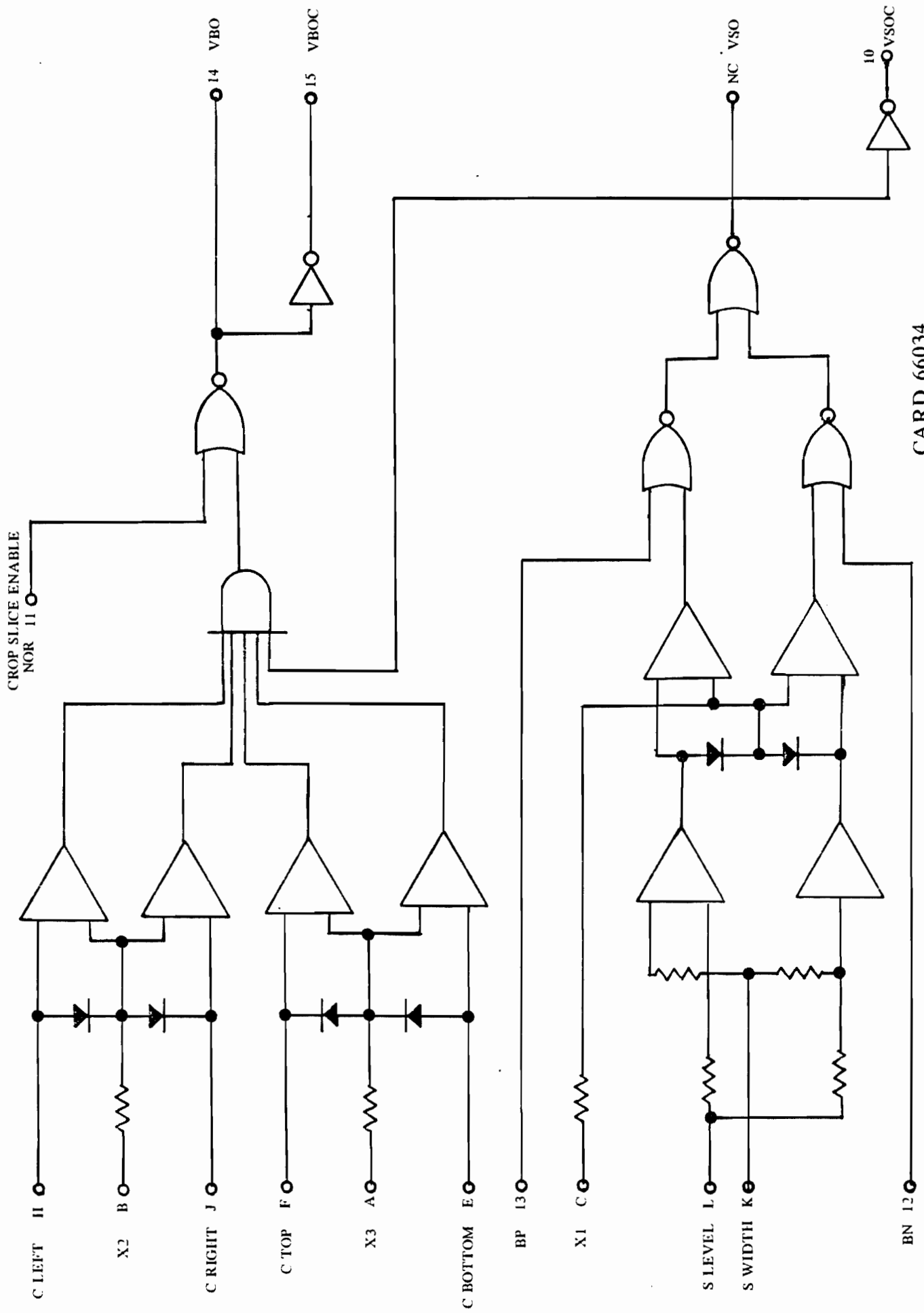

FUNCTIONAL BLOCK DIAGRAM FOR THE CROP/Slice MODULE NO. 6194 ON THE 66034 CARD.
 FIGURE 534

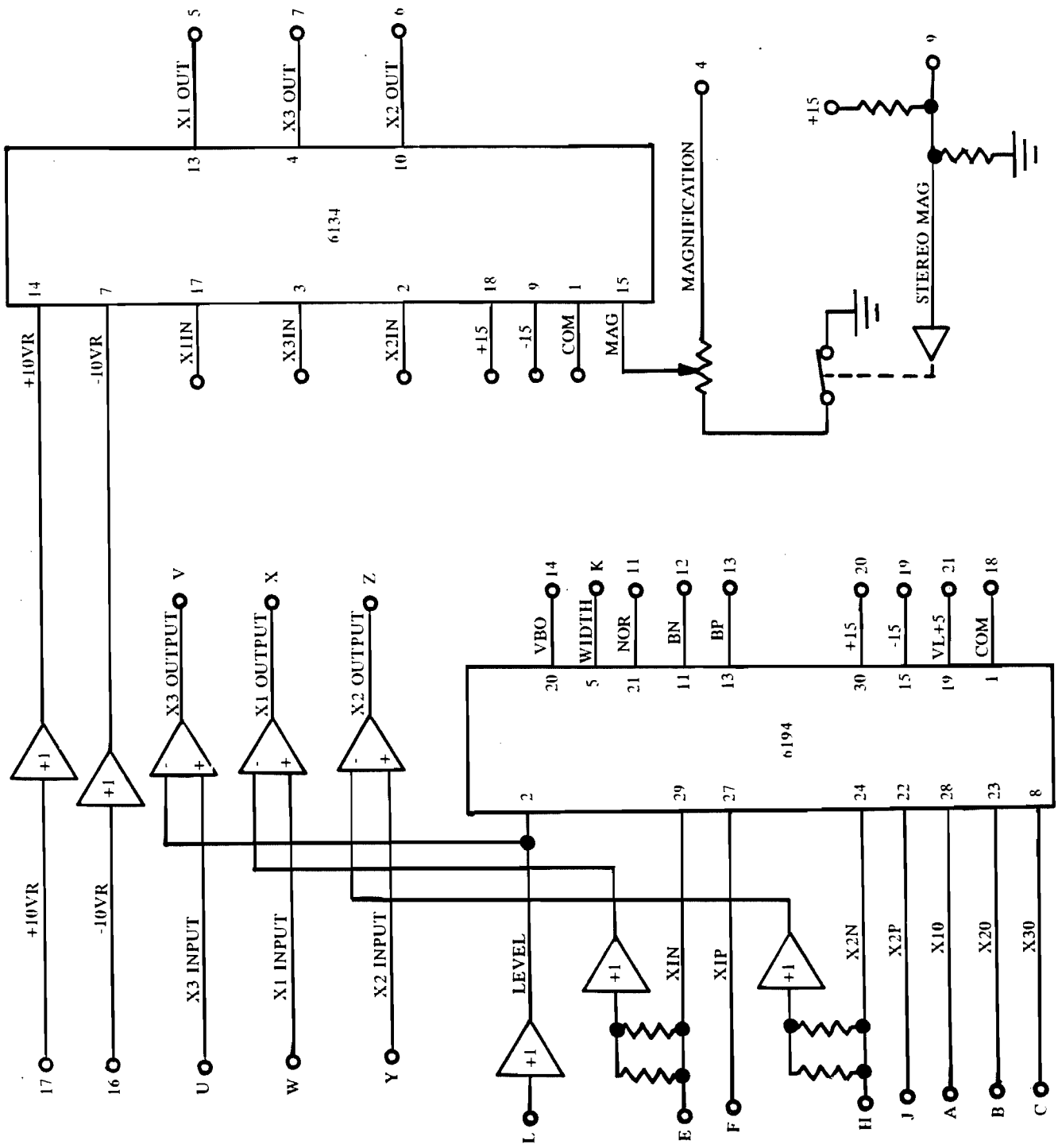

FIGURE 5.3.5 BLOCK DIAGRAM OF THE CROP SLICE AND ZOOM CARD, MODEL 66034

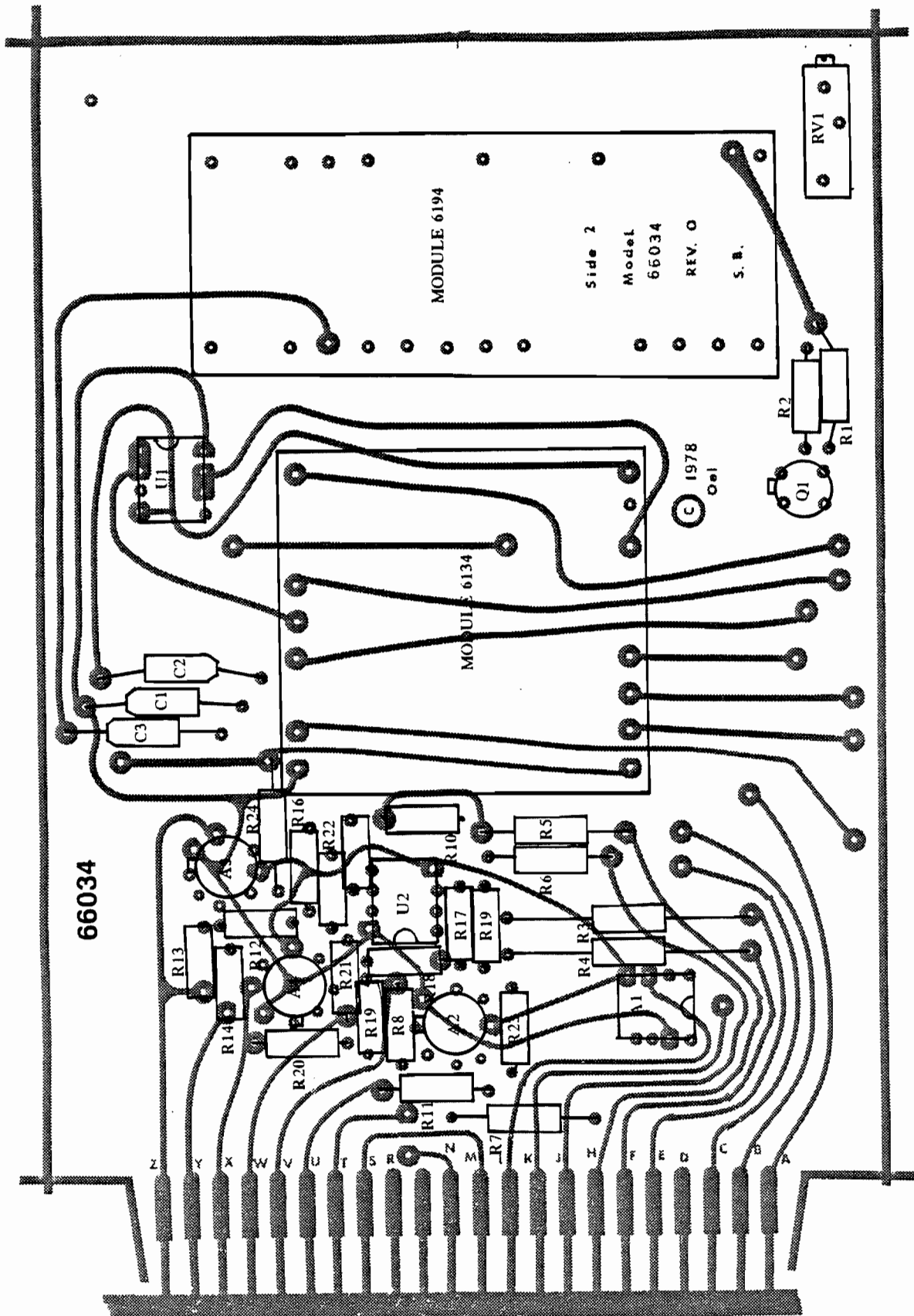

FIGURE 5.3.6 COMPONENT LAYOUT FOR THE 66034 CARD.

SECTION 5.4

BASIC 3-D SYSTEM CARD Card Model No.: 66014

Module 6114 and the associated 66014 card form the heart of the 3-D display system. The module generates the aerial and geometric perspective, interposition and movement parallax cues.

The complete card schematic diagram is given in Figure 5.4.1; however, the auxillary amplifiers are not used in the 3-D manipulator. All 66014 cards are supplied with the auxillary amplifiers and components. The inputs to the amplifiers are set to zero by grounding pins 1, 2 and 3 in the 3-D manipulator. The card configuration used in the 3-D manipulator is given in Figure 5.4.2.

The internal module function block diagram is shown in Figure 5.4.3.

The component layout for Card No. 66014 is shown in Figure 5.4.4, and the card pin test is given in Table 5.4.1. The component list is given in Table 5.4.2.

Two high speed multipliers are used to generate the three-dimensional effects seen on the X-Y monitor display. The vertical and horizontal translation control voltages are also applied as inputs to translate the image on the monitor.

TABLE 5.4.1
 BASIC 3-D DISPLAY

CARD NO. 66014

<u>PIN</u>	<u>FUNCTION</u>
20	+15 Volts
19	-15 Volts
18	Common
17	+V REF
16	-V REF
14	P In
13	V Out
12	H Out
10	X30
8	X20
6	X10
3	X3 In
2	X2 In
1	X1 In
S	6170 - E0+
R	X3P
N	X2P
M	6170 - 0 - 0
K	V - Translation
H	H - Translation

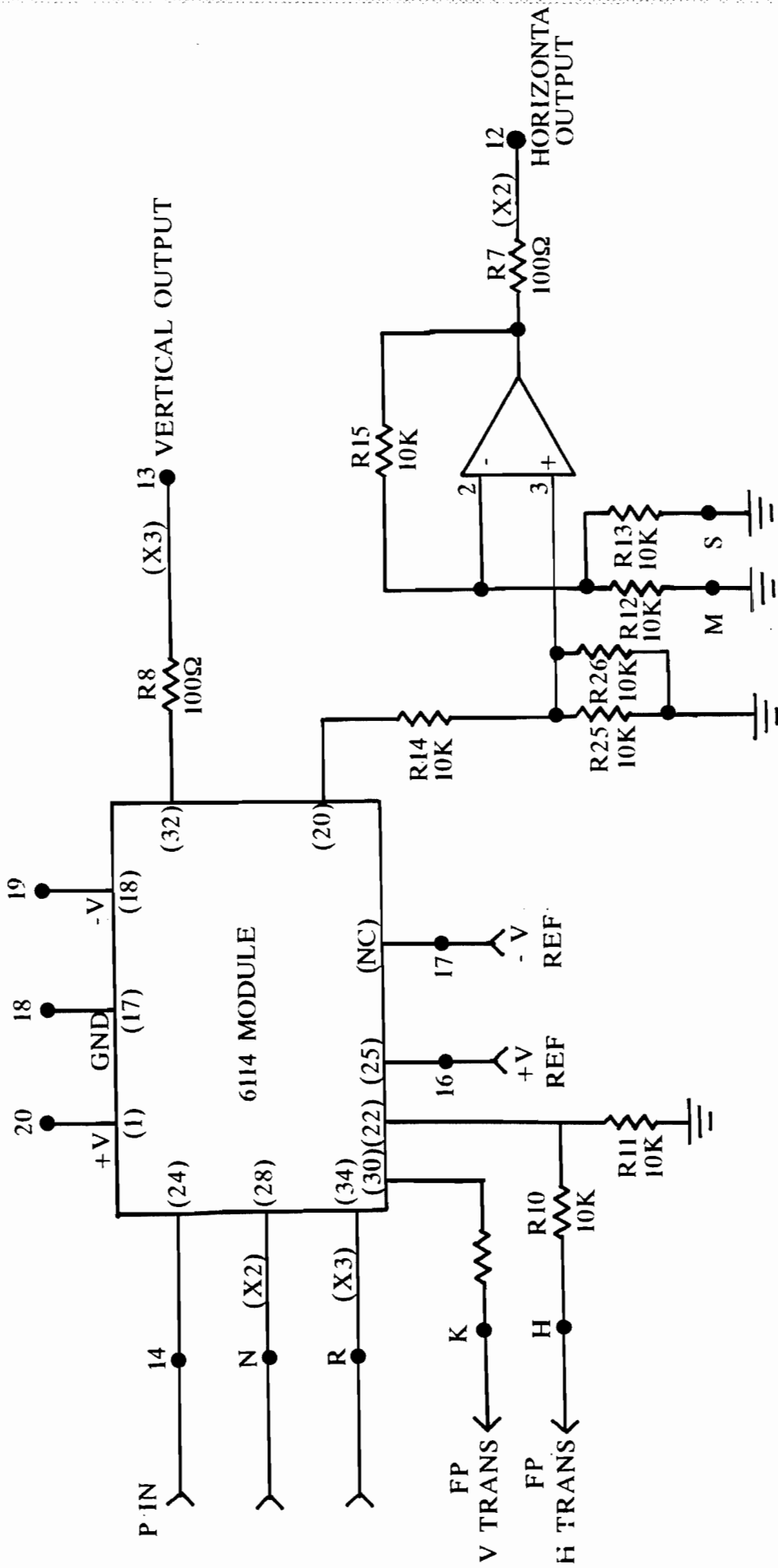
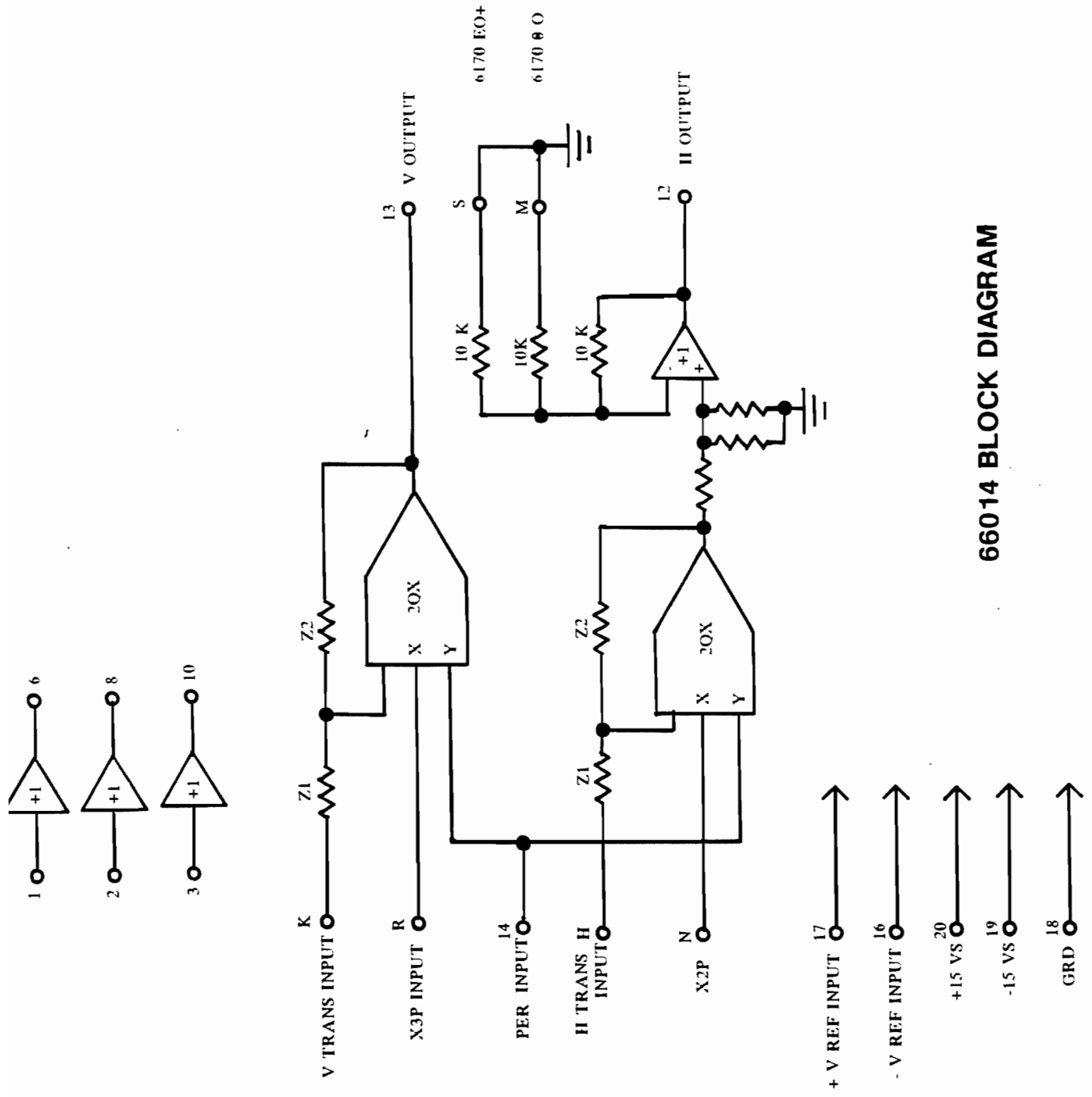

FIGURE 5.4.2 CARD CONFIGURATION FOR USE IN THE 3-D DISPLAY SYSTEM

TABLE 5.4.2

MODEL NO. 66014DATE 10-9-87PARTS LIST

QTY	ID#	PART #	DESCRIPTION	MFGR #	MFGR NAME
1	41	150206	IC OP Amp/Buf	LM318H	National
4	C10, 11 12, 13	180023	Capacitor/uF		Kemet
3	C1, 2, 3	180034	Capacitor 100 pF NPO		Corning
6	C4, 5, 6, 7, 8, 9	180040	Capacitor 33 pF NPO		Kemet
3	RV22, 23 24	191643	Resistor, Variable	RT5L104 100K 20T	Allen Bradley/ Bour
5	R4, 5, 6, 7, 8		Resistor 100 OHMS		
3	R1, 2, 3		Resistor 1K		
3	R16, 18 20		Resistor 2.2K		
2	R9, 10		Resistor 10K		
7	R11, 12, 13 14, 15, 25, 26		Resistor 10K 1%		
3	R17, 19, 21		Resistor 30K		



66014 BLOCK DIAGRAM

FIGURE 5.4.3 BLOCK DIAGRAM OF THE BASIC 3D SYSTEM

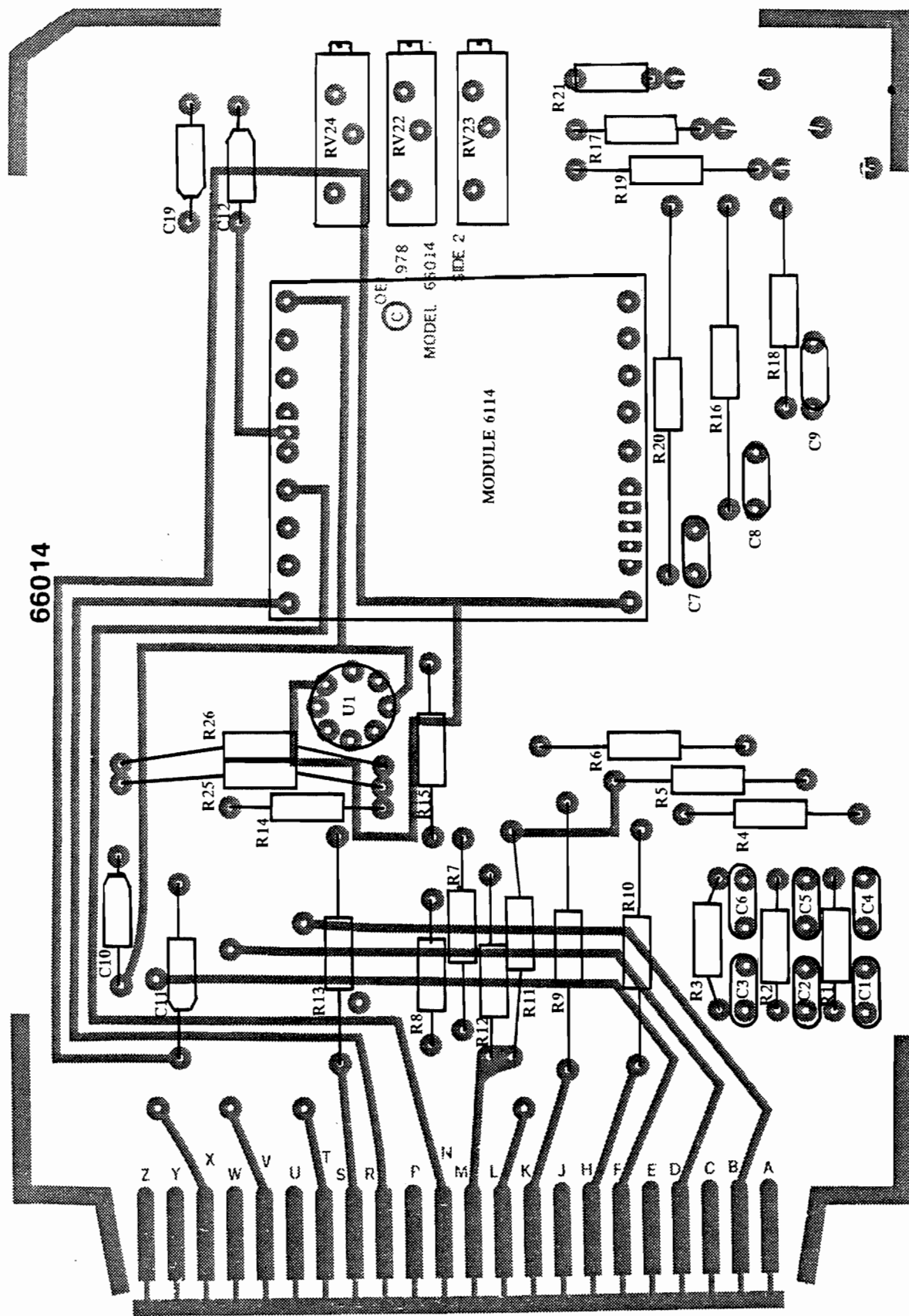

FIGURE 5.4.4 COMPONENT LAYOUT FOR THE 3-D SYSTEM CARD , MODEL NO 66014

SECTION 5.5

3-D VIDEO OUTPUT CARD

Card Model No.: 66082A

X1 Size

The X1 Size control, Figure 5.5.1, varies the amplitude of the X1 vector, or Z axis. An analog multiplier connected between card pin 1, 3 and 6 provides a controllable gain which is directly proportional to the control voltage applied to pin 1; pin 6 is the vector input value and the corresponding product term is on pin 3. The control voltage input ranges from zero to +10VDC.

Line Drivers

The inputs to the X-Y monitor are all terminated by 50 ohm resistors to match the coaxial cable interface, Figure 5.5.2. The result is that the line driver amplifiers on the 66082A must all be capable of driving the 50 lines. Amplifiers U17, U5 and U6 are designed to drive the 50 lines. The 51 resistors in series with the amplifiers matches the termination and line impedance. The line drivers are unity gain (+1) amplifiers.

Blanking and Contrast

The Z output from the 66082A is used to modulate the intensity of the X-Y monitor, Figure 5.5.3. The amplifier arrangement preceding the Z line driver, U17, combines the intensity functions, contrast and shading, along with the blanking signal, to generate the beam modulation input signal.

If the blanking signal goes low, zero volts, the output of the Z line driver will be 1.0 volts which will cut the beam off. The output then ranges from +1.0 volts, beam cut off, to 0.0V, beam at full intensity.

Note, care should be taken to insure that the beam intensity does not exceed the limits of the X-Y monitor and damage the screen. The intensity control of the X-Y monitor will change the intensity range of the total system. The monitors intensity should be kept as low as possible during system set-up to avoid overdriving the beam current.

Perspective and Shading

The perspective function operates on an image in such a manner as to reduce the width of the image which is in the background as illustrated in Figure 5.5.4. The visual effect of the resulting image is similar to that of a perspective drawing.

The shading function allows shading to be added to the image to increase the contrast within the image.

Card Schematics

The card schematic for the 66082A is given in Figure 5.5.5a and b. Component layout is shown in Figure 5.5.6, the component list is given in Table 5.5.1.

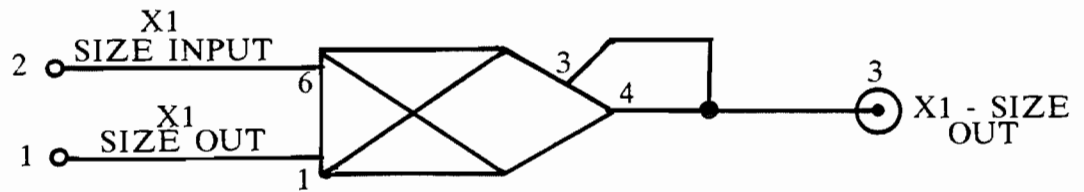

FIGURE 5.5.1 BLOCK DIAGRAM FOR X1 - SIZE CONTROL. (66082A)

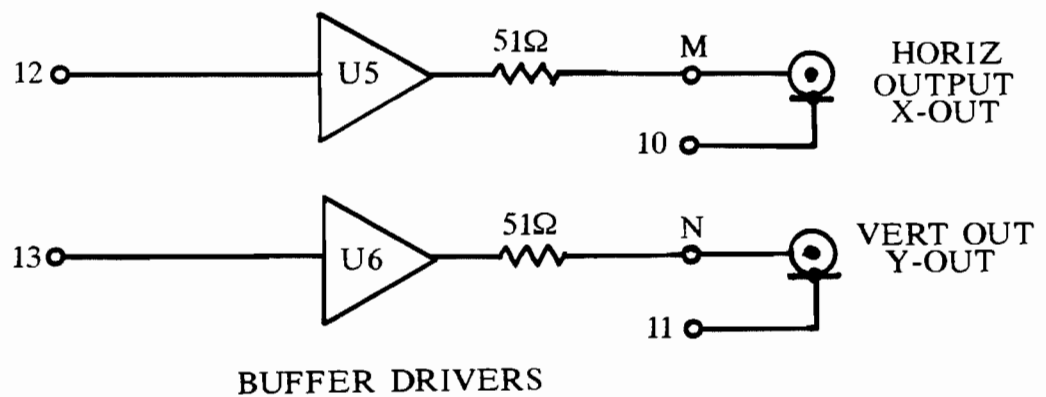

FIGURE 5.5.2 HORIZONTAL AND VERTICAL LINE DRIVERS, $Z_o = 50\Omega$. (66082A)

TABLE 5.5.1

MODEL NO. 66082ADATE 10-9-87PARTS LIST

QTY	ID#	PART #	DESCRIPTION	MFGR #	MFGR NAME
5	U5,6,10 14,17	150440	Integrated Circuit	HA-5033-5	Harris
3	U11,16 15	15046	Integrated Circuit	LM318N	National
1	U9	150386	I.C. Wide Band Dual	LF353N	National
3	U4,7,8	150257	I.C. 4 Quad Analog Multiplier	ICL-8013-CCTZ	Intersil
1	U13	150435	Integrated Circuit	MM74HC27N	National
2	U2,3	150481	I.C.	OP27EP	PMI
1	U1	150417	I.C. Prec. Volt Ref.	REF 01 EZ	PMI
3	D1,2,3	160040	Diode	1N6263	Hewlett Packard
1	Q1	170131	Trans PNP	2N 6710	National
1	Q2	170132	Trans NPN	2N 6707	National
43	C1-44	180020	Capacitor 0.1 uF		Kemet
29	C45-72	180023	Capacitor 1.0 uF		Kemet
2	C73,74	180075	Capacitor 10 Micro F		Kemet
2	C28,35	180008	Capacitor 100 pF		Corning
2			Resistor 30		
3			Resistor 51		
2			Resistor 100		
6			Resistor 1K		
11			Resistor 10K		
15	RV1-15	191642	Resistor 10K Variable 20 Turn	3006P-1-103	Bourns

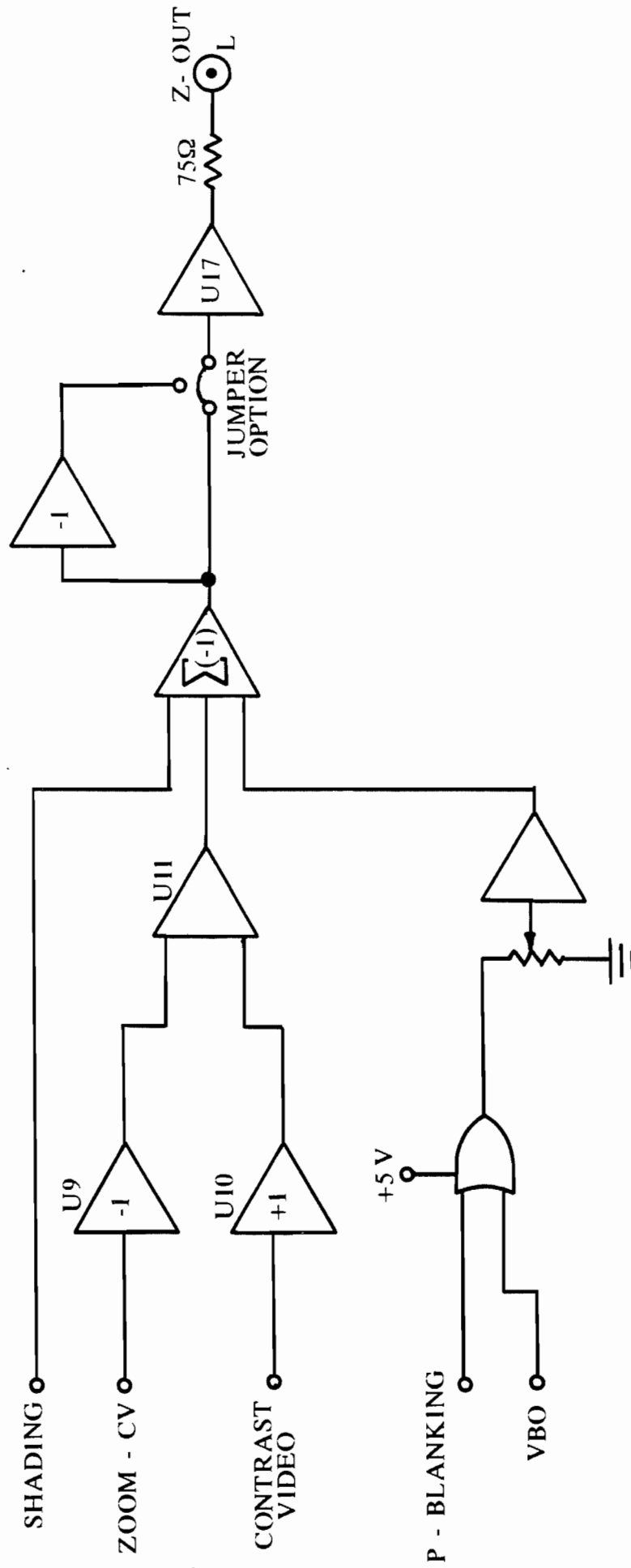

FIGURE 5.5.3 BLOCK DIAGRAM FOR THE BLANKING AND CONTRAST SYSTEM

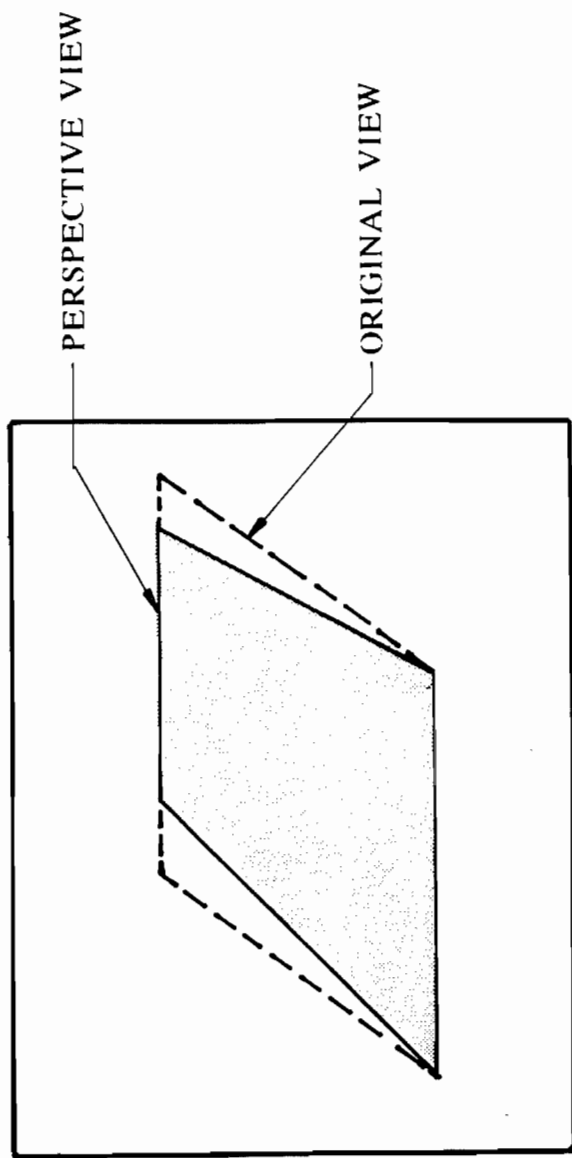
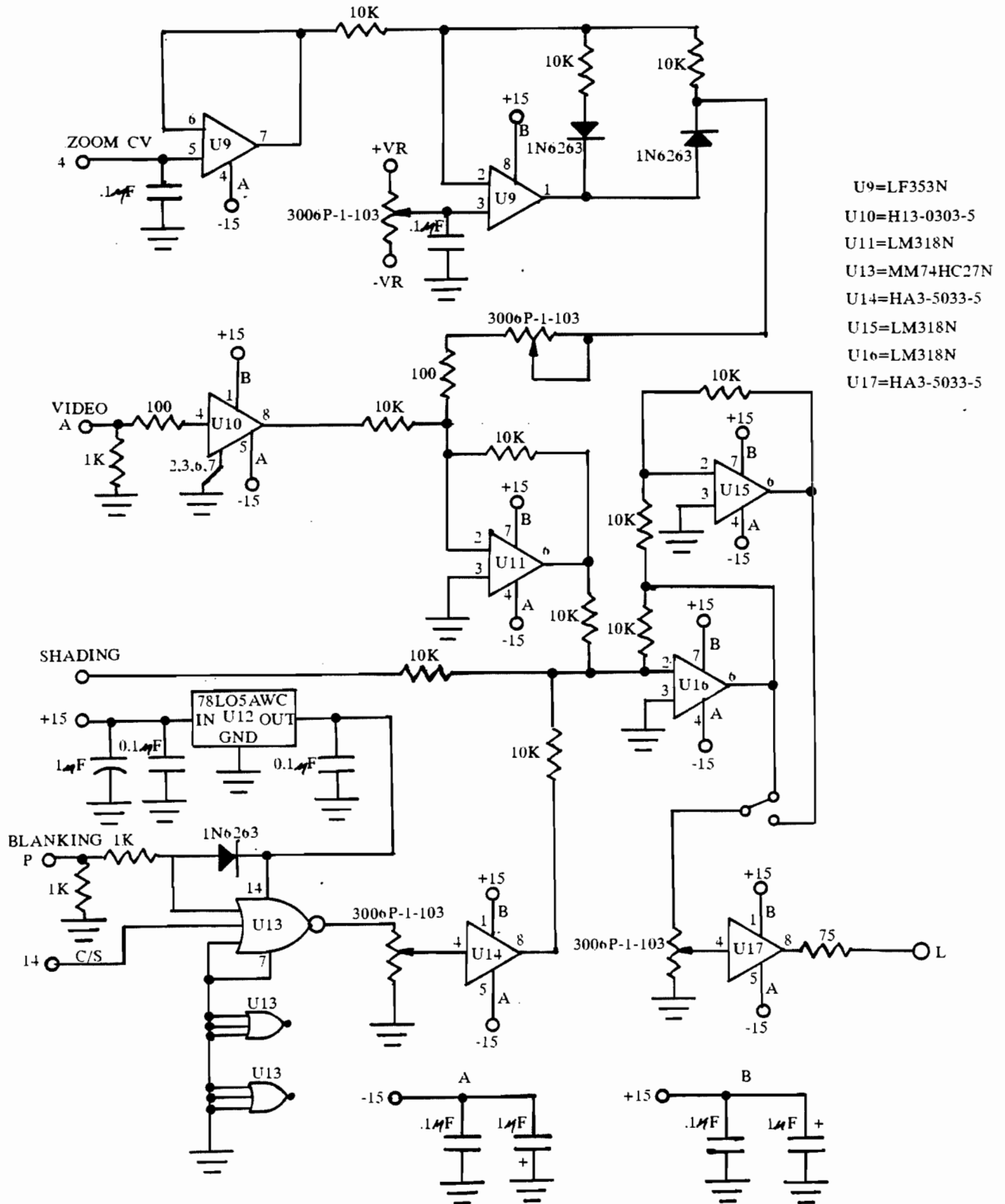
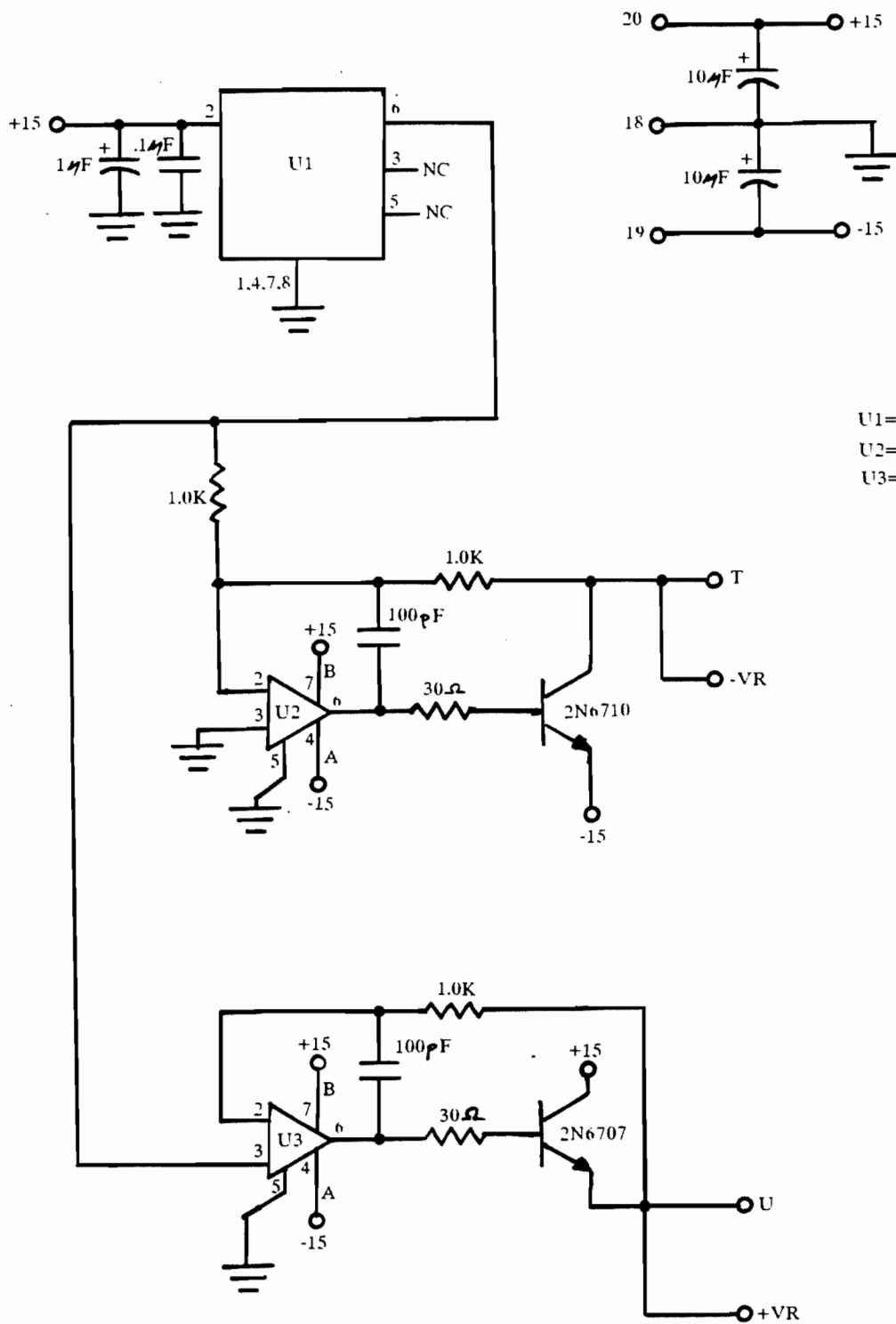

FIGURE 5.5.4 PERSPECTIVE VIEW OF THE VIDEO IMAGE WITH THE WIDTH OF THE BACKGROUND REDUCED.



NOTE 1. PLACE CAPACITORS WITHIN .3 INCHES OF IC PIN CONNECTOR

FIGURE 5.5.5a SCHEMATIC FOR THE 3-D VIDEO OUTPUT CARD (66082A)



U1=REF01EZ
 U2=OP27EP
 U3=OP27EP

FIGURE 5.5.5b SCHEMATIC FOR THE REFERENCE POWER SUPPLIES ON CARD 66082A.

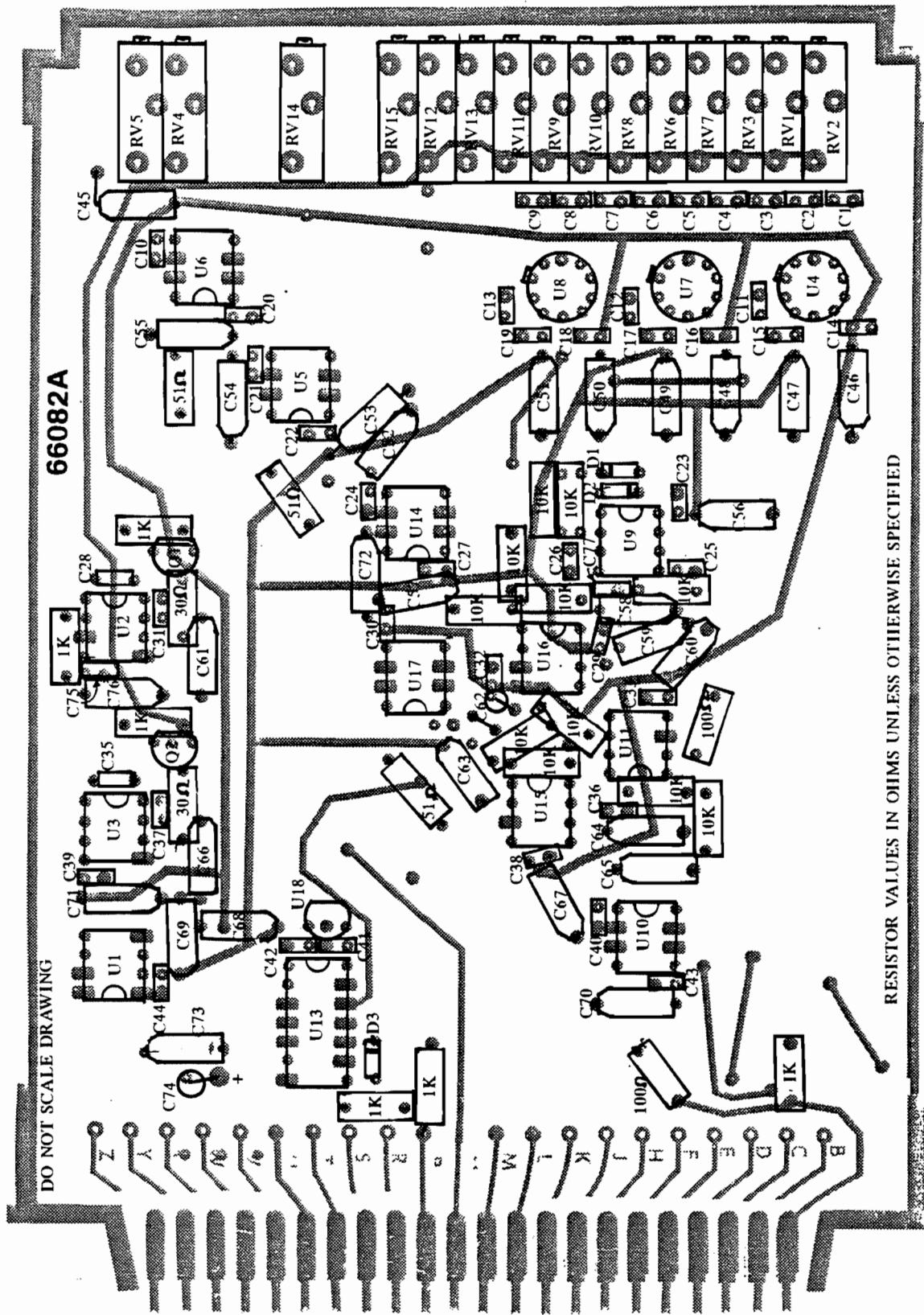

FIGURE 5.5.6 COMPONENT LAYOUT FOR CARD 66082A

SECTION 5.6

IMAGE ROTATOR CARD

Card Model No.: 66025

The image rotator card is used in conjunction with the image rotator module, No. 6125, in a 3-D system. The module and card may also be used in other systems for the rotation of vector information. The rotation angle is a function of the angle voltage input. The module can produce a full 360° of rotation.

VECTOR ROTATION

The rotation of a point (X,Y), as shown in Figure 5.6.1, is accomplished by the following transform:

$$\begin{aligned} X' &= X \cos\theta - Y \sin\theta \\ Y' &= X \sin\theta + Y \cos\theta, \end{aligned}$$

where X', Y' are the new coordinate points following a rotation of θ degrees. A counterclockwise rotation is considered to be a positive angle. Rotation is about the Z axis which does not reside in the plane formed by the X and Y axes.

The position of the initial point (X,Y) is supplied to the rotator module as two proportional voltages. The third input is a voltage which is proportional to the angle of rotation. The functional block diagram of the module is illustrated in Figure 5.6.2.

The voltage, θ , which is proportional to the angle of rotation is converted through a sine/cosine generator into two voltages which correspond to the values of $\sin\theta$ and $\cos\theta$. Four high frequency multipliers provide the respective trigonometric product terms. Two amplifiers then complete the rotation function by summing the correct terms. The outputs X' and Y' are the new vector coordinates of point (X,Y) after rotation through the angle θ .

The 6125-A performance curves are given in Figure 5.6.3. Note that a zero degree rotation corresponds to a -10.0VDC input on pin 9, 0. Zero volts corresponds to a 180° rotation as shown in Figure 5.6.3.

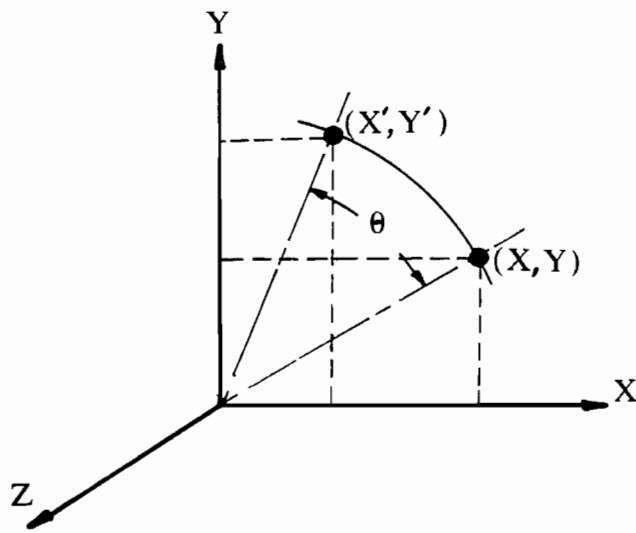

FIGURE 5.6.1 THE ROTATION OF THE POINT (X, Y) THROUGH THE POSITIVE ANGLE θ TO THE NEW COORDINATES (X', Y') .

SPECIFICATIONS

ELECTRICAL

Specifications at $T_A = +25^\circ\text{C}$. $V_{CC} = \pm 15\text{VDC}$ unless otherwise noted.

MODEL	6125A				
PARAMETER	CONDITION	MIN	TYP	MAX	UNITS
TRANSFER FUNCTION					
A-0 B-0		$A_{in} \cos \theta - B_{in} \sin \theta$ $B_{in} \cos \theta + A_{in} \sin \theta$			
RATED OUTPUT					
Voltage Current A_O, B_O Resistance	$I_o = \pm 10\text{mA}$, $R_L = 1\text{K}\Omega$ $V_o = \pm 10\text{V}$, $R_L = 1\text{K}\Omega$	± 10 ± 10		1	V mA Ω
DYNAMIC RESPONSE					
Trigonometric Functions Small Signal Bandwidth Multiplier Small Signal Bandwidth Trigonometric Functions Large Signal Bandwidth Multiplier Large Signal Bandwidth Output Slewing Rate		300 1 30 500	30		kHz MHz kHz kHz V/ μsec
REFERENCE VOLTAGE					
	$I_o = \pm 10\text{mA}$		± 10.0		V
INPUT OFFSET VOLTAGE					
Input Offset Voltage-R Input Input Offset Voltage Drift Output Offset Voltage Output Offset Temperature Coefficient Power Supply Sensitivity				± 20 ± 1 ± 20 ± 2 ± 25	mV mV/ $^\circ\text{C}$ mV mV/ $^\circ\text{C}$ mV/V
ERROR					
Sine Error Cosine Error Multiplication Error Total Error			0.3	0.3 0.3 0.5 0.5	% % % %
INPUT					
Angle \leftrightarrow Resistance Angle \leftrightarrow Voltage Range Ain, Bin Resistance Ain, Bin Voltage Range ² Maximum Voltage Without Damage		100 ± 10 1 ± 10 $\pm V_s$			M Ω V M Ω V V
INPUT VOLTAGE RANGE					
\leftrightarrow Input R Input	Linear Operation	± 10 ± 10			V V
POWER SUPPLY					
Rated Voltage Current, Quiescent		± 12	± 15	± 18 ± 120	V mA
TEMPERATURE RANGE					
Operating Range Storage Range Thermal Resistance of Module Quiescent Temperature Rise		-55 -65		+85 +100 10 13	$^\circ\text{C}$ $^\circ\text{C}$ $^\circ\text{C}/\text{W}$ $^\circ\text{C}$ Above Ambient

TABLE 5.6.1

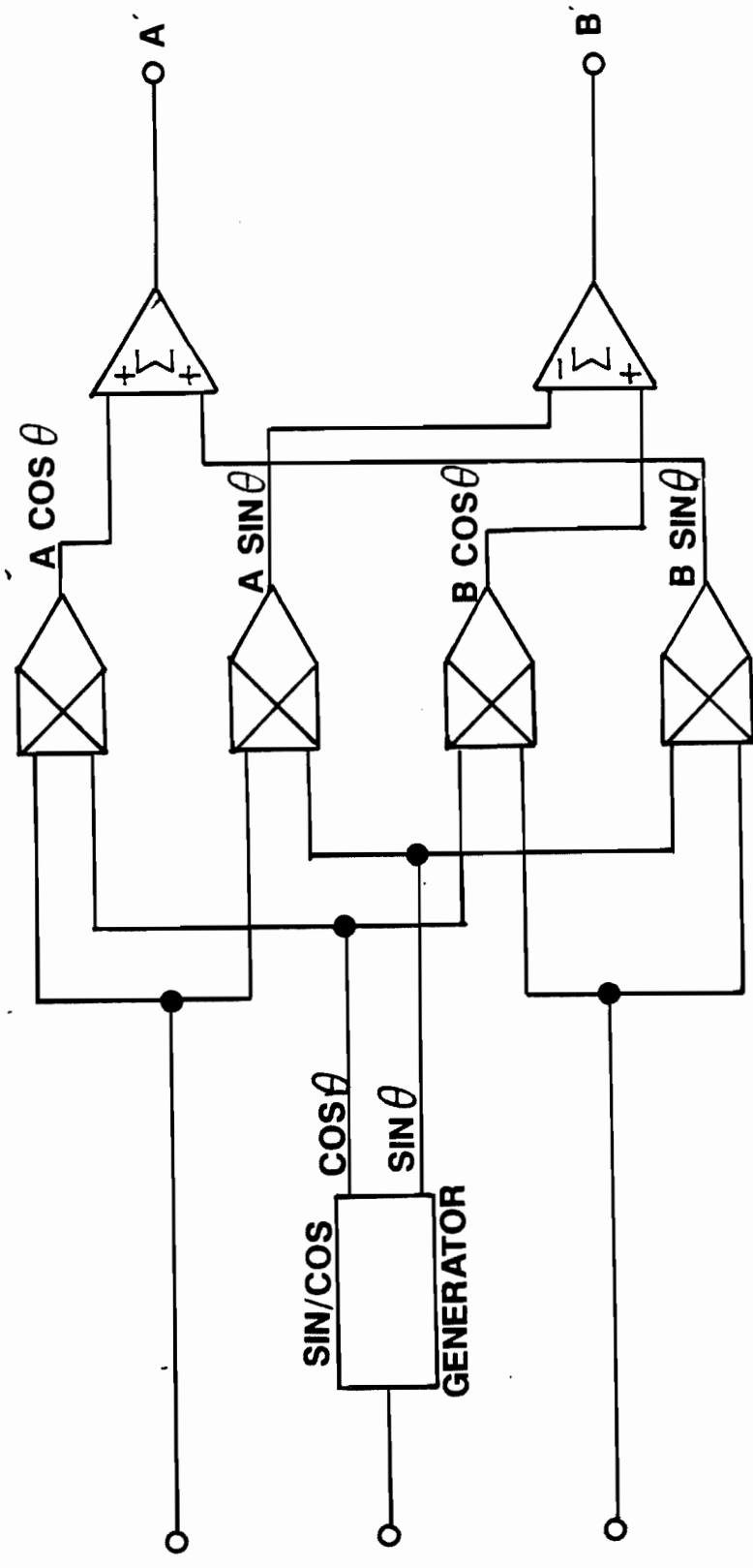

$$A' = A \cos \theta - B \sin \theta$$

$$B' = A \sin \theta + B \cos \theta$$

FIGURE 5.6.2 FUNCTIONAL BLOCK DIAGRAM OF ROTATOR MODULE NO. 6125

TABLE 5.6.2

MODEL NO. 66025

DATE 10-9-87

PARTS LIST

QTY	ID #	PART #	DESCRIPTION	MFGR #	MFGR NAME
4	C1,2,3,4	180023	Capacitor 1.0 Micro F		Kemet
2	R3,4		Resistor 100		
2	R1,2		Resistor 1K		

6125-A
TYPICAL PERFORMANCE CURVES

(T_A = +25°C, V_{CC} = ±15VDC unless otherwise noted)

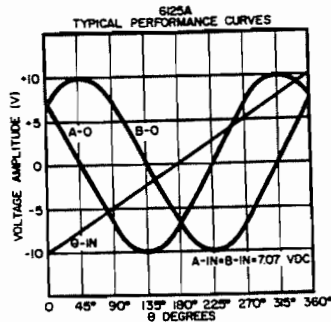

FIGURE 5.6.3

The vector inputs have a band width of 500KHZ and the angle input has a band width of 30KHZ.

The rotator modules may be used in combination to produce multi axis rotation. Given three orthogonal vectors X1, X2 and X3 as illustrated in Figure 5.6.4; rotation about the X1 axis is accomplished with the (X2,X3) vectors; rotation about the X2 axis is accomplished with the (X1,X3) vectors; and rotation about the X3 axis is accomplished with the (X1,X2) vectors. Figure 5.6.5 illustrates the module configuration for three axes rotation in the 3-D system.

MODULE SPECIFICATIONS

The card schematic is shown in Figure 5.6.6 and the component layout is illustrated in Figure 5.6.7. Specifications for the card and module are given in Table 5.6.1.

The component list is given in Table 5.6.2 and the edge connector pin list is given in Table 5.6.3.

TABLE 5.6.3

CARD INTERCONNECTIONS

EDGE CONNECTOR

CARD NO. 66025

<u>PIN</u>	<u>FUNCTION</u>
20	+15V
19	-15V
18	Common
17	+VREF-Out
16	-VREF-Out
9	0
7	B Out
5	B In
3	A Out
1	A In

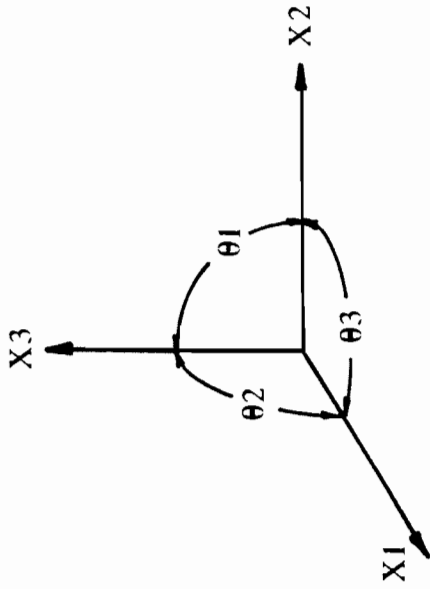

THE THREE INPUT AXES X1, X2, AND X3 MAY BE ROTATED A FULL 360° AROUND EACH AXIS, X1, X2, AND X3.

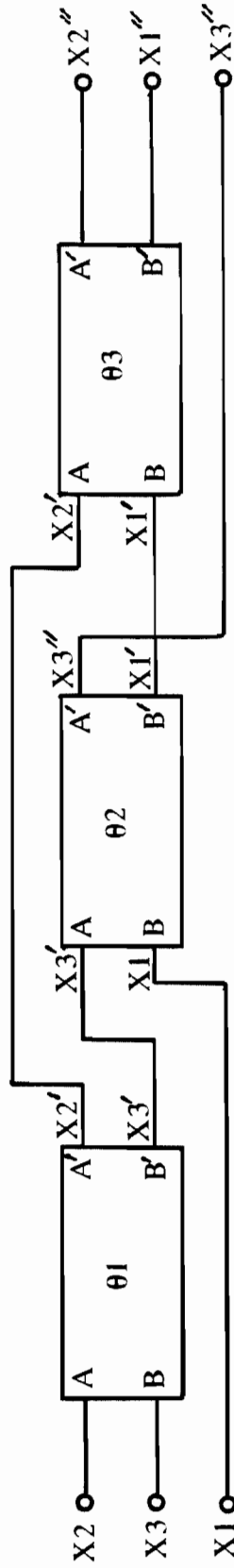

FIGURE 5.6.4

SCHEMATIC REPRESENTATION OF 3 AXES OF ROTATION USING 6125 ROTATION MODULES.

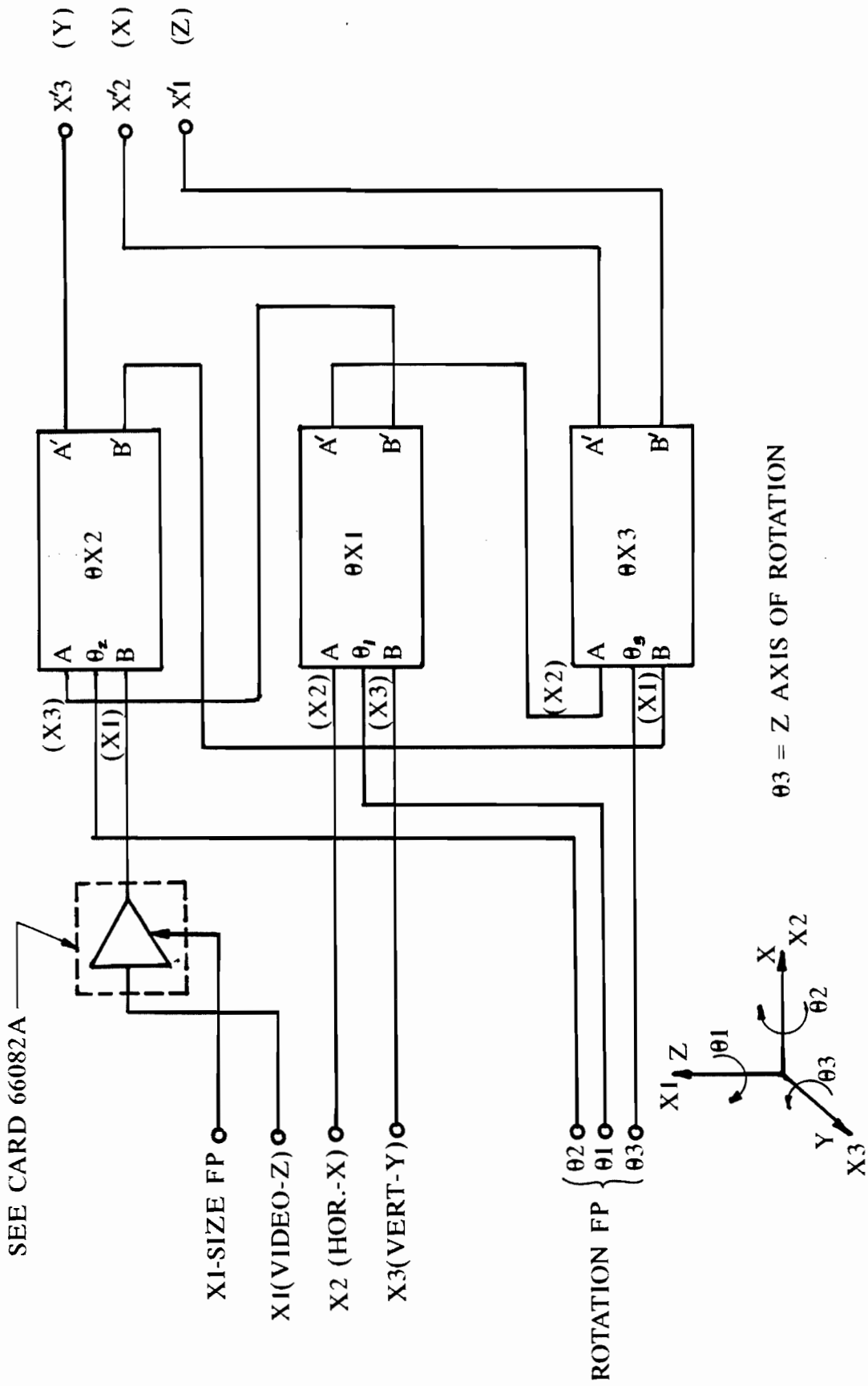

FIGURE 5.6.5 FUNCTIONAL BLOCK DIAGRAM FOR THREE AXES OF ROTATION

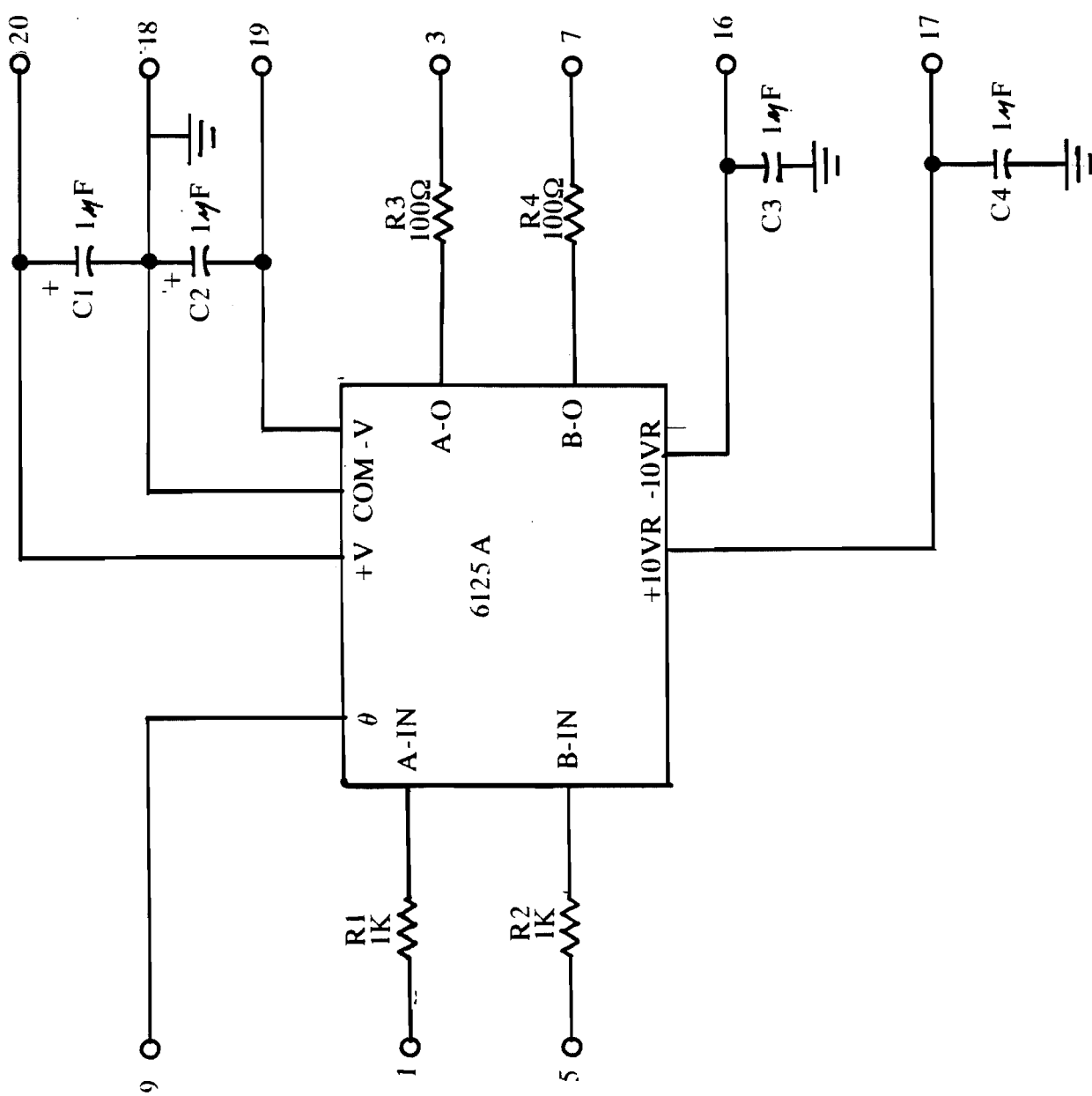

FIGURE 5.6.6 CARD SCHEMATIC 66025

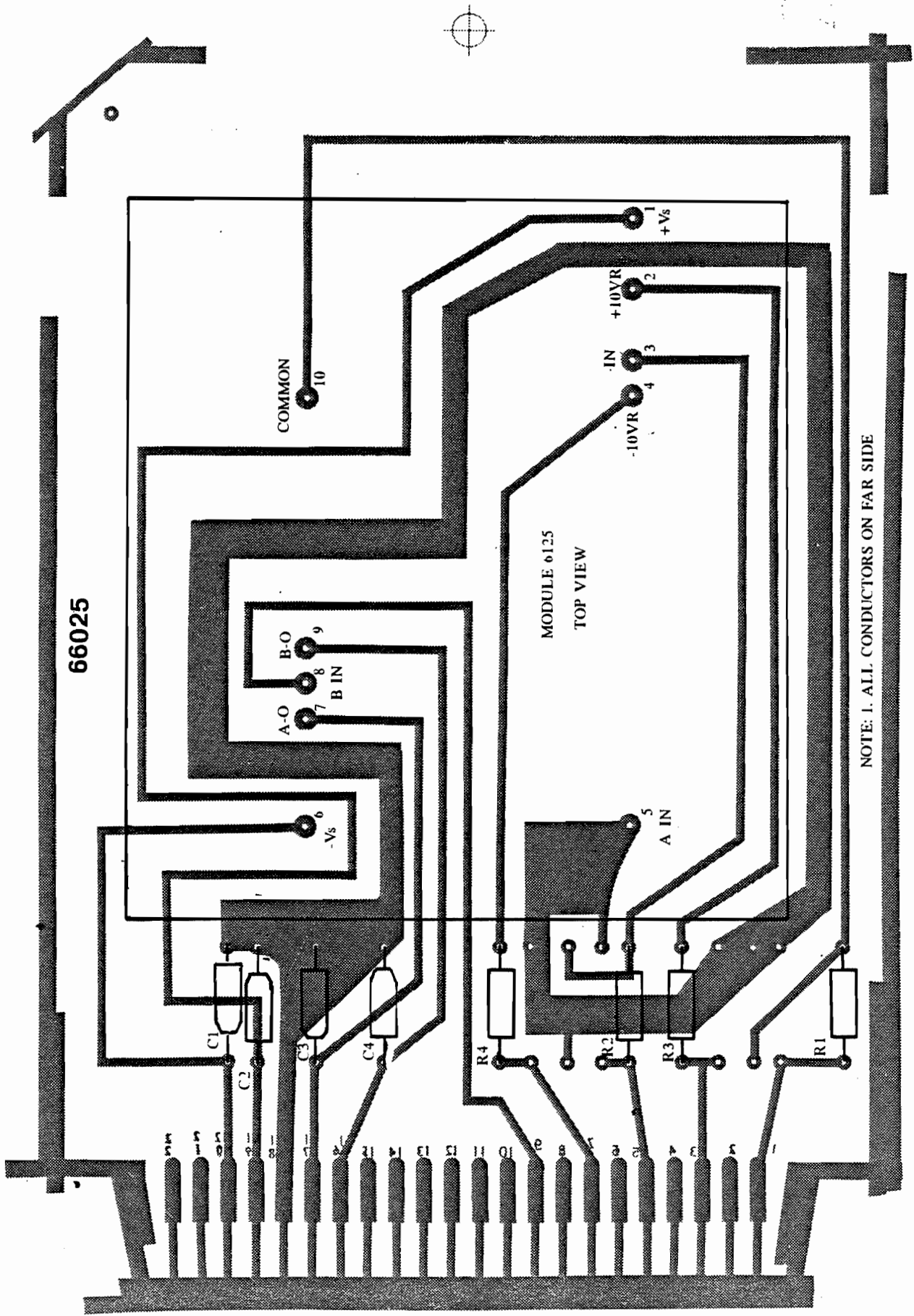

FIGURE 5.6.7 COMPONENT LAYOUT NO, 66025